

Serial No.

2110

REVISED

MAR 1995

MASTER COPY

IF YOU NEED A BOOK, THE PRINTER'S  
ASSISTANT WILL MAKE YOU A COPY !!

DO NOT TAKE FROM FILE

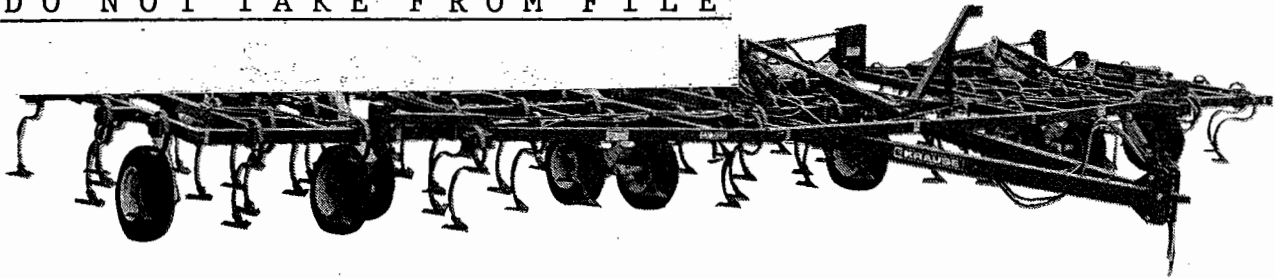

# FLEX-WING FIELD CULTIVATOR

## MODELS

4218, 4223, 4226,

4231, 4237, 4241.

# KRAUSE

P.O. BOX 2707 / 305 SOUTH MONROE STREET

HUTCHINSON, KANSAS 67504-2707

# *Congratulations*

You have just purchased a quality designed and manufactured Krause tillage tool. Advanced features have been designed into the implement for modern farming operations. As with any investment, a return is expected, and the return received from this investment will be in the form of maximum tillage performance during many years of dependable service.

In order to maintain quality performance of the new Krause implement, it is important that all of the information in the manual be reviewed and studied carefully before operation. The contents provide operating instructions, maintenance instructions, and information on how to make adjustments.

## **SAFETY ALERT SYMBOL**



**BE ALERT TO THE POSSIBILITY OF  
PERSONAL INJURY. THIS SYMBOL  
IDENTIFIES IMPORTANT SAFETY  
MESSAGES. CAREFULLY READ THE  
MESSAGE THAT FOLLOWS.**

MODEL NUMBER \_\_\_\_\_ SERIAL NUMBER \_\_\_\_\_

PURCHASE RECORD -- DATE \_\_\_\_\_

# Warranty

## KRAUSE PLOW CORPORATION Hutchinson, Kansas

The Krause Plow Corporation, Hutchinson, Kansas, expressly warrants each new product manufactured by it to be free from defects in material and workmanship under normal use and service for a period of one year after delivery to the original retail purchaser or first user of the product.

Krause's obligation under this warranty is limited to repairing and/or replacing, at its option, any part or parts within the applicable one year period, as set out above, which shall be returned by the owner or any Krause authorized dealer to the factory and which upon examination shall disclose to Krause's satisfaction to be defective.

Krause may, at its option, elect to grant adjustments in the field through an authorized representative and may thereby elect to waive the requirement that parts be returned to Krause's factory.

A new warranty period is not established for replacements. Replacements are warranted for the remaining portion of the one year original warranty period. The repair or replacement of defective parts under this warranty will be made without charge to the owner except for transportation.

Krause does not warrant disc blades, tires, chisel shanks, hydraulic cylinders, accessories and other parts not manufactured by it, but supplied with or as a part of its products. Krause will, however, obtain and pass on any adjustments provided by the manufacturers of such parts under these manufacturer's warranties.

The provisions of this warranty do not apply to any product or parts which have been subject to misuse, negligence or accident, or which have been repaired or altered outside of Krause's factory in any way so as in the judgement of Krause to affect adversely its performance and reliability. Neither does this warranty apply to normal maintenance service and parts, or to normal deterioration due to wear and exposure.

**To the extent allowed by applicable law, this warranty is expressly in lieu of other warranties, expressed or implied, in fact or by law, including any implied warranty of merchantability or fitness for a particular purpose. The remedies of repair or replacement as set forth are the only remedies under this warranty. Krause disclaims any obligations or liability for loss of time, inconvenience, commercial loss or direct, consequential, special or incidental damages. This warranty is in lieu of any other obligation or liability of Krause of any nature whatsoever by reason of the manufacture, sale, lease or use of such products and Krause neither assumes, nor authorizes anyone to assume for it, any other obligation or liability in connection with such products.**

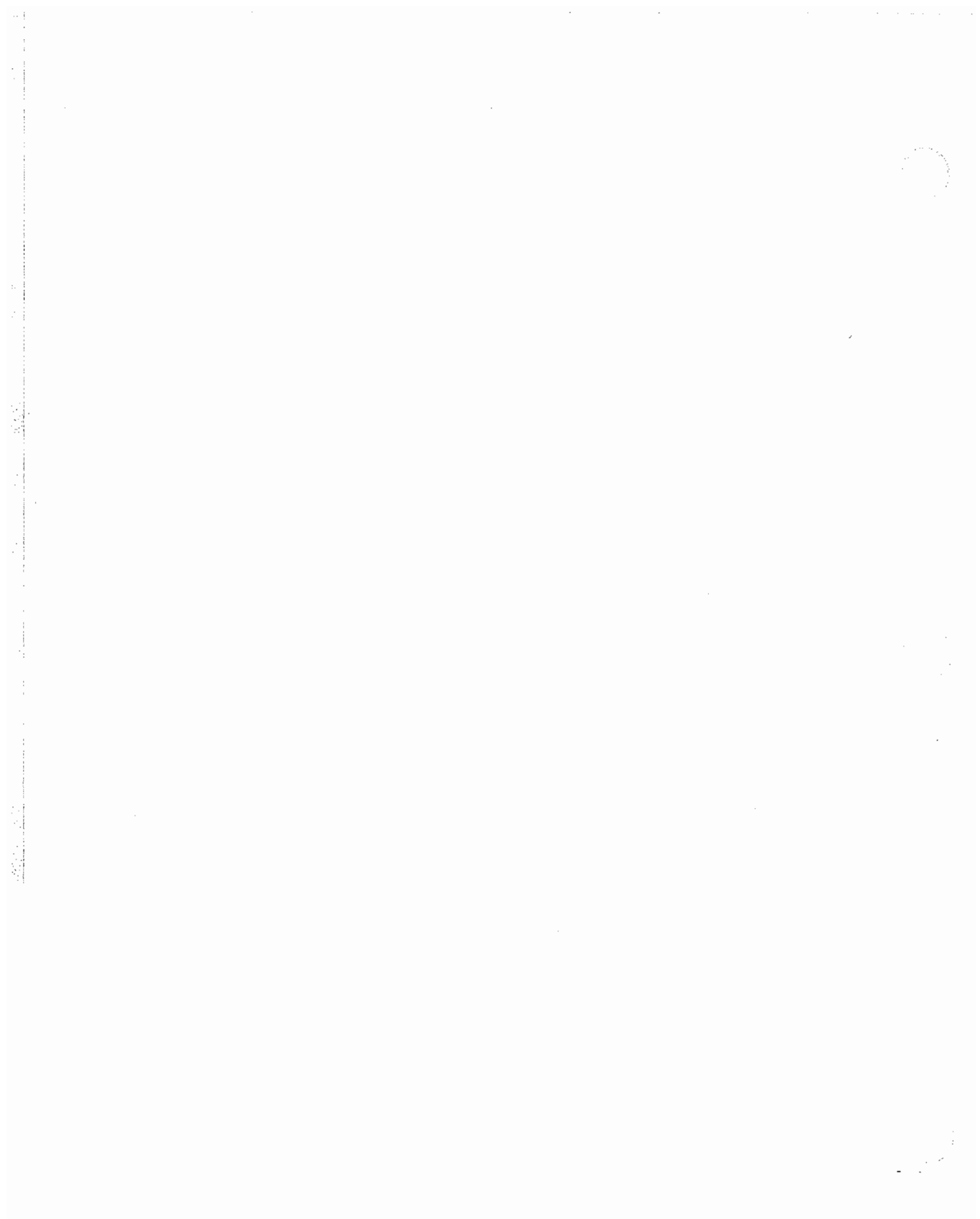

# 4200 SERIES FLEX WING FIELD CULTIVATOR DEALER PREDELIVERY CHECK SHEET

TO BE CHECKED BY DEALER

CUSTOMER \_\_\_\_\_ DATE \_\_\_\_\_

ADDRESS \_\_\_\_\_

DEALER \_\_\_\_\_

ADDRESS \_\_\_\_\_

MODEL \_\_\_\_\_ SERIAL NUMBER \_\_\_\_\_

## DEALER CHECK:

1. \_\_\_ Check to see that all rocker shaft bolts are tight and pins are in place.
2. \_\_\_ Check to see that hydraulic cylinders are full of oil (air bled out of cylinders). Clevis pins with hair pin clips should be in place. Hydraulic system requires 14 Quarts for Models 4218 & 4223, 24 Quarts for models 4226 & 4231, and 38 Quarts for Models 4237 & 4241.
3. \_\_\_ Examine hydraulic hoses to see that they are protected from damage.
4. \_\_\_ Bolts attaching the walking tandem to the wheel arms should be tight. Check to see that bearings have been adjusted and greased.
5. \_\_\_ Check lug bolts holding wheels to the hub to see that they are torqued from 90 to 95 Ft. Lbs.
6. \_\_\_ The correct size tire should be on the implement. Model 4218 & 4223 Center Single Tires: 11L x 15, 6-Ply with 32 P.S.I. pressure. Model 4226 & 4231 Center Tires: 9.5L x 15, 6-Ply with 32 P.S.I. pressure. Models 4237 & 4241 Center Tires: 9.5L x 15, 8-Ply with 44 P.S.I. pressure.
7. \_\_\_ Check to see that bolts attaching hitch to frame and clevis weldment to hitch are in place and tightened.
8. \_\_\_ Jack should be operational for support of tongue when implement is not attached to a tractor.
9. \_\_\_ Wing was attached with special pins and secured with self locking nuts.
10. \_\_\_ Road lock and wing lock was correctly installed and operate satisfactorily.
11. \_\_\_ Restrictor is installed in wing lift cylinder rod end ports.
12. \_\_\_ All decals are in place per page P66 of this owner's manual.
13. \_\_\_ Customer review sheet is filled out and signed.
14. \_\_\_ Review lighting requirements. Light kits available.

DELIVERED BY \_\_\_\_\_

DATE \_\_\_\_\_

# 4200 SERIES FLEX WING FIELD CULTIVATOR CUSTOMER REVIEW SHEET

CUSTOMER \_\_\_\_\_ DATE \_\_\_\_\_

ADDRESS \_\_\_\_\_

DEALER \_\_\_\_\_

ADDRESS \_\_\_\_\_

MODEL \_\_\_\_\_ SERIAL NUMBER \_\_\_\_\_

1. \_\_\_ Owner's manual provided.
2. \_\_\_ Warranty card filled out and mailed.
3. \_\_\_ Review safety warnings and cautions as listed in this owner's manual.
4. \_\_\_ Review recommended maximum road speed, width, and height for implement.
5. \_\_\_ Review field operational speeds, horsepower, depth and rock conditions.
6. \_\_\_ Demonstrate the proper use of road locks.
7. \_\_\_ Explain the hydraulic depth control system. To change the depth, raise cultivator out of the ground and rotate the depth stop knob in or out the same amount on every rocker.
8. \_\_\_ Review limitations of additional weight and transport speed when adding attachments.
9. \_\_\_ Explain the importance of maintaining the tools through lubrication, checking that bolts are kept tight, and replacement of worn or broken parts.
10. \_\_\_ Recommend that a safety chain be used with the implement.
11. \_\_\_ Check wheel lug bolts frequently until they become set.
12. \_\_\_ Explain lighting requirements for your area.

DEALER \_\_\_\_\_ DATE \_\_\_\_\_

CUSTOMER \_\_\_\_\_ DATE \_\_\_\_\_

# Table of Contents

WARRANTY		WING FRAME (4223)	P17
DEALER PREDELIVERY CHECK SHEET	1	WING FRAME (4226)	P19
CUSTOMER REVIEW SHEET	2	WING FRAME (4231)	P21
TABLE OF CONTENTS	3	WING FRAME (4237)	P23
SPECIFICATIONS	4-5	WING FRAME (4241)	P25
GENERAL INFORMATION DRAWING	6	WING ROCKER ASSEMBLY	P27
TRANSPORT PHOTOGRAPH	7	OUTSIDE WING & ROCKER (4237 - 4241)	P29
<u>OPERATION SECTION</u>		SHANK EXTENSION WELDMENTS	P30
ABOUT YOUR FIELD CULTIVATOR	O1	FOLD OVER EXTENSIONS	P31
PREPARING FOR OPERATION	O1	CENTER WALKING BEAM ASSEMBLY	P33
PREPARING THE TRACTOR	O2	WING WALKING BEAM ASSEMBLY	P35
HYDRAULIC SYSTEM	O2	SINGLE AXLE & HUB ASSEMBLY	P36
HITCHING & UNHITCHING	O2	WING SECTION HUB ASSEMBLY	P37
Hitching To The Tractor	O3	WHEELS & TIRES	P38
Unhitching From The Tractor	O3	REAR JACK MOUNT & TIRE SCRAPERS	P39
TRANSPORTING	O4	SPRING SHANK ASSEMBLY	P41
Road Lock	O4	K-TINE SHANK ASSEMBLY	P43
Raising The Wings	O4	2-PIECE K-TINE SHANK ASSEMBLY	P45
Lowering The Wings	O5	GAUGE WHEEL ASSEMBLY	P47
Transport Safety	O5	PACKER HITCH ASSEMBLY	P48
Hitch Pin	O6	TRAIL HITCH ASSEMBLY	P49
FIELD ADJUSTMENTS	O6	HYDRAULIC HOSE GROUP (4218,4223)	P51
UNDERSTANDING DEPTH CONTROL	O7	HYDRAULIC HOSE GROUP (4226, 4231)	P53
Depth adjustment procedure	O7	HYDRAULIC HOSE GROUP (4237)	P55
Leveling From Front To Rear	O8	HYDRAULIC HOSE GROUP (4241)	P57
Leveling From Side To Side	O8	HOSE ASSEMBLIES WITH PLASTIC GRIP HANDLES	P58
Understanding Your Rephasing System	O9	4" x 8" REPHASING CYLINDER	P59
Flexibility	O10	4-1/4" x 8" REPHASING CYLINDER	P60
Turning In The Field	O10	4-1/2" x 8" REPHASING CYLINDER	P61
Field Speed	O10	4-3/4" x 8" HYDRAULIC CYLINDER	P62
GENERAL INFORMATION	O10	4" x 16" HYDRAULIC CYLINDER	P63
SERVICING		4" x 32" WING LIFT CYLINDER	P64
General Maintenance	O11	4" x 24" WING LIFT CYLINDER	P65
Lubrication	O11	DECALS	P66
Wheel Bearings	O11	<u>ASSEMBLY SECTION</u>	
Walking Beam Maintenance	O11	SAFETY & BASIC ASSEMBLY INFORMATION	A3
Folding Extensions	O12	I. CENTER SECTION FOR (Models 4218 & 4223)	A4
Spring Shank Repair	O12	II. CENTER SECTION FOR (Models 4226, - 4241)	A8
Models 4237 & 4241 Wing Fold Sequence Valve	O13	III. WING FRAME & ROCKERS	A14
HYDRAULIC SAFETY PLEASE READ CAREFULLY	O14	IV. MODEL 4236 OUTER WING ASS'M.	A19
Storage	O15	V. MODEL 4241 WING BRACE & OUTER WING	A20
Repair Parts	O15	VI. SHANK EXTENSION (For All Models)	A22
SUGGESTED REMEDIES SECTION	O15- O17	VII. SHANK ASSEMBLY	A24-A28
<u>PARTS SECTION</u>		VIII. HYDRAULIC	A29
MAIN FRAME (4218, 4223)	P3	IX. TRAIL HITCH	A35
CENTER ROCKER / ROAD LOCK (4218,4223)	P5	X. REAR FRAME STAND	A36
SELF LEVELING TONGUE (4218, 4223)	P7	XI. LEVELING THE CULTIVATOR	A36
MAIN FRAME (4226 - 4241)	P9	XII. DECALS	A37
CENTER ROCKER /ROAD LOCK	P11	4200 TINE HARROW SPECIFICATIONS	A38
SELF LEVELING TONGUE (4226 - 4241)	P13	4200 SPIKE HARROW SPECIFICATIONS	A39
WING FRAME (4218)	P15	4200 REEL / TINE SPECIFICATIONS	A40
		PLACEMENT DRAWINGS	A41 - A58

# 4200 FIELD CULTIVATOR TRANSPORT SPECIFICATIONS

3/93

MODEL	A ROADING WIDTH	B WING LESS EXTENSION	C ONE SHANK EXTENSION	D TWO SHANK EXTENSION	E THREE SHANK EXTENSION
4218	11' - 8-1/2"	9' - 6-3/4"	9' - 10-1/2"	10' - 5-1/4"	11' - 0"
4223	11' - 8-1/2"	11' - 6-3/4"	12' - 1-1/2"	12' - 8-1/4"	13' - 3"
4226	15' - 1"	11' - 6-3/4"	12' - 1-1/2"	12' - 8-1/4"	13' - 3"
4231	15' - 1"	13' - 10"	14' - 5"	14' - 0" Folded	14' - 0" Folded
4237	15' - 1"	11' - 8"	11' - 8"	11' - 8"	11' - 8"
4241	15' - 1"	14' - 0"	14' - 0"	14' - 0"	14' - 0"

	F	G
4218 & 4223 (Single Wheels)	—	103"
4218 & 4223 (Dual Wheels)	65"	103"
4226, 4231, 4237 & 4241	105-1/2"	143-1/2"

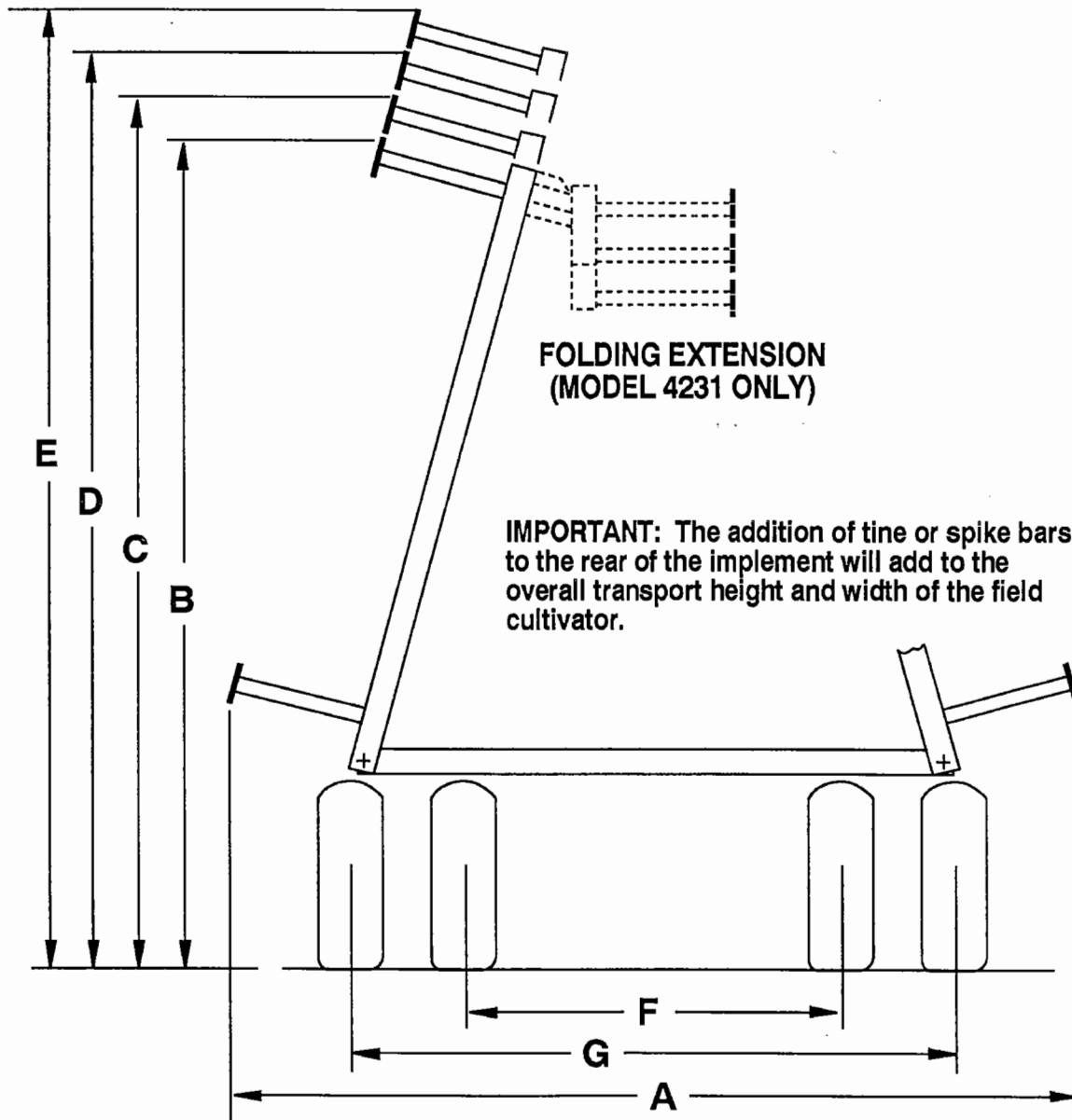

## 4200 FIELD CULTIVATOR SPECIFICATIONS

MODEL	CUT WIDTH	BASIC WEIGHT	TOTAL SHANKS	SHANKS CENTER	SHANKS INSIDE WINGS	SHANKS OUTSIDE WINGS
4218	18' - 1"	4,804 #	31	13	9	—————
	19' - 3"		33		10	
	20' - 5"		35		11	
	21' - 7"		37		12	
4223	22' - 9"	5,425 #	39	13	13	—————
	23' - 11"		41		14	
	25' - 1"		43		15	
	26' - 3"		45		16	
4226	26' - 3"	6,453 #	45	19	13	—————
	27' - 5"		47		14	
	28' - 7"		49		15	
	29' - 9"		51		16	
4231	30' - 11"	7,483 #	53	19	17	—————
	32' - 1"		55		18	
	33' - 3"		57		19	
	34' - 5"		59		20	
4237	36' - 9"	#	61	19	13	9
	37' - 11"		63			10
	39' - 1"		65			11
	40' - 3"		67			13
4241	41' - 5"	9,823 #	71	19	17	9
	42' - 7"		73			10
	43' - 9"		75			11
	44' - 11"		77			13

1. MODELS 4218 & 4223 use a one piece welded 13 SHANK center frame.
2. MODELS 4237 & 4241 are 5-Section Cultivators with single wheels on the outer wings.

NOTE: 1 See placement pages at the back of owner's manual for center and wing dimensions.

### HYDRAULICS

DEPTH CONTROL	4-1/2" x 8" Cylinder	28-1/4" Extended	20-1/4" Retracted
	4-1/4" x 8" Cylinder	28-1/4" Extended	20-1/4" Retracted
	4" x 8" Cylinder	28-1/4" Extended	20-1/4" Retracted

NOTE: Cylinders listed above **rephase when fully retracted.**

WING LIFT	4" x 16" Cylinder	47-1/2" Extended	31-1/2" Retracted
	4" x 32" Cylinder	74-3/4" Extended	42-3/4" Retracted

# GENERAL INFORMATION

ALWAYS PIN TRACTOR DRAWBAR BEFORE TRANSPORTING. USE A SAFETY CHAIN WITH THE TENSILE STRENGTH EQUAL TO THE GROSS WEIGHT OF THE LOAD BEING TOWED.

ROAD AT A REASONABLE SPEED DO NOT EXCEED 20 M.P.H.

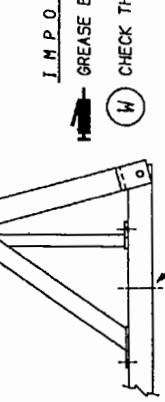
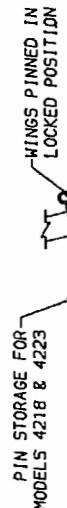
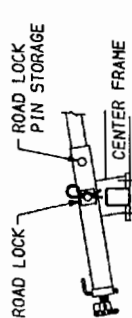

### IMPORTANT

GREASE EACH 24 HOURS OF USE

CHECK THESE POINTS PERIODICALLY FOR WEAR

FULLY RETRACT DEPTH CONTROL CYLINDERS & HOLD TRACTOR VALVE OPEN A FEW SECONDS TO SYNCHRONIZE WING CYLINDERS.

NOTE: CULTIVATOR IS IN RAISED POSITION WHEN ROCKER CYLINDERS ARE FULLY RETRACTED

CHECK TIRE PRESSURE BEFORE OPERATION.  
9.5L 6 PLY = 32 P.S.I.  
11L 6 PLY = 32 P.S.I.  
9.5L 8 PLY = 44 P.S.I

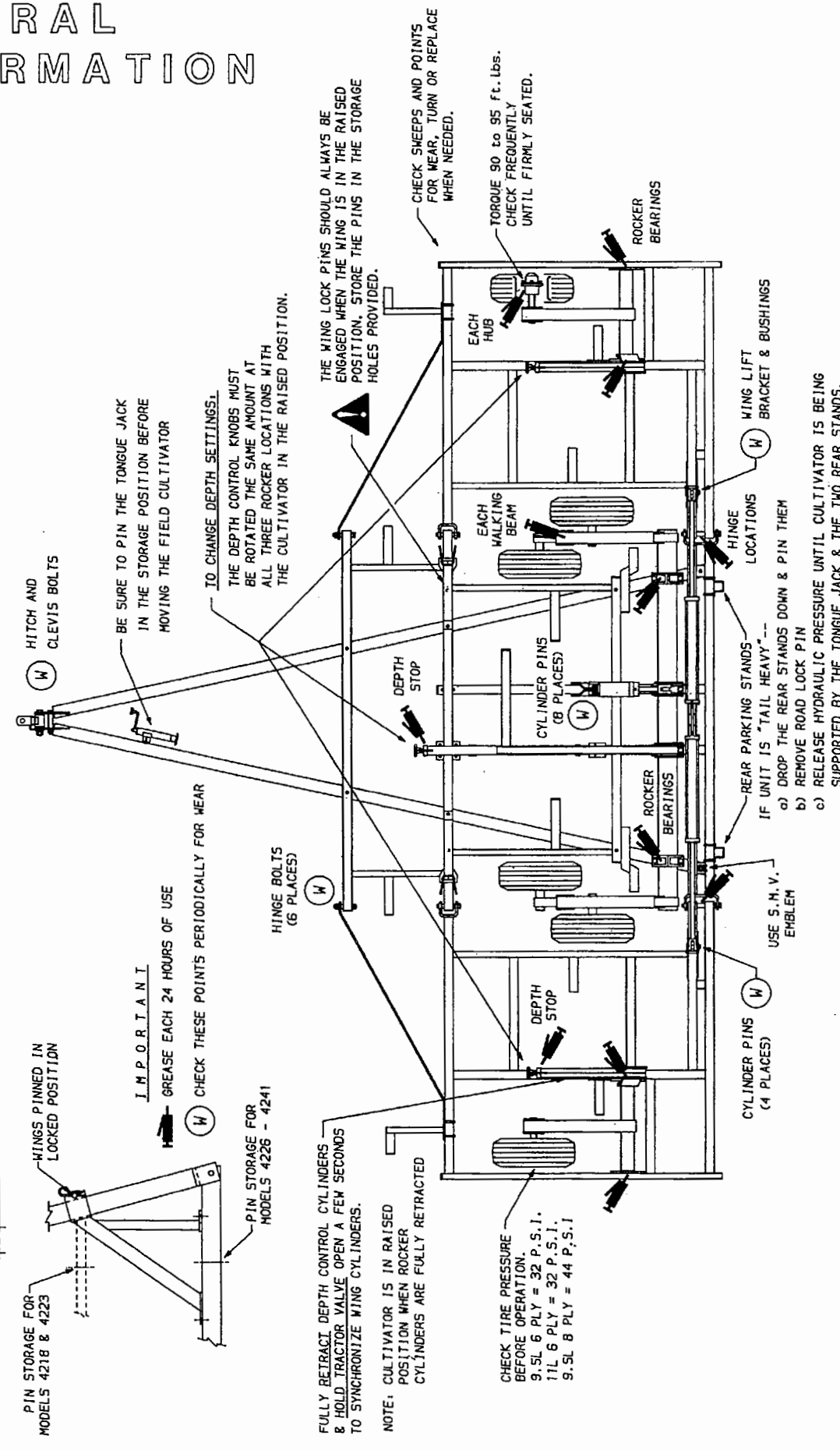

**MODEL 4241 SHOWN**

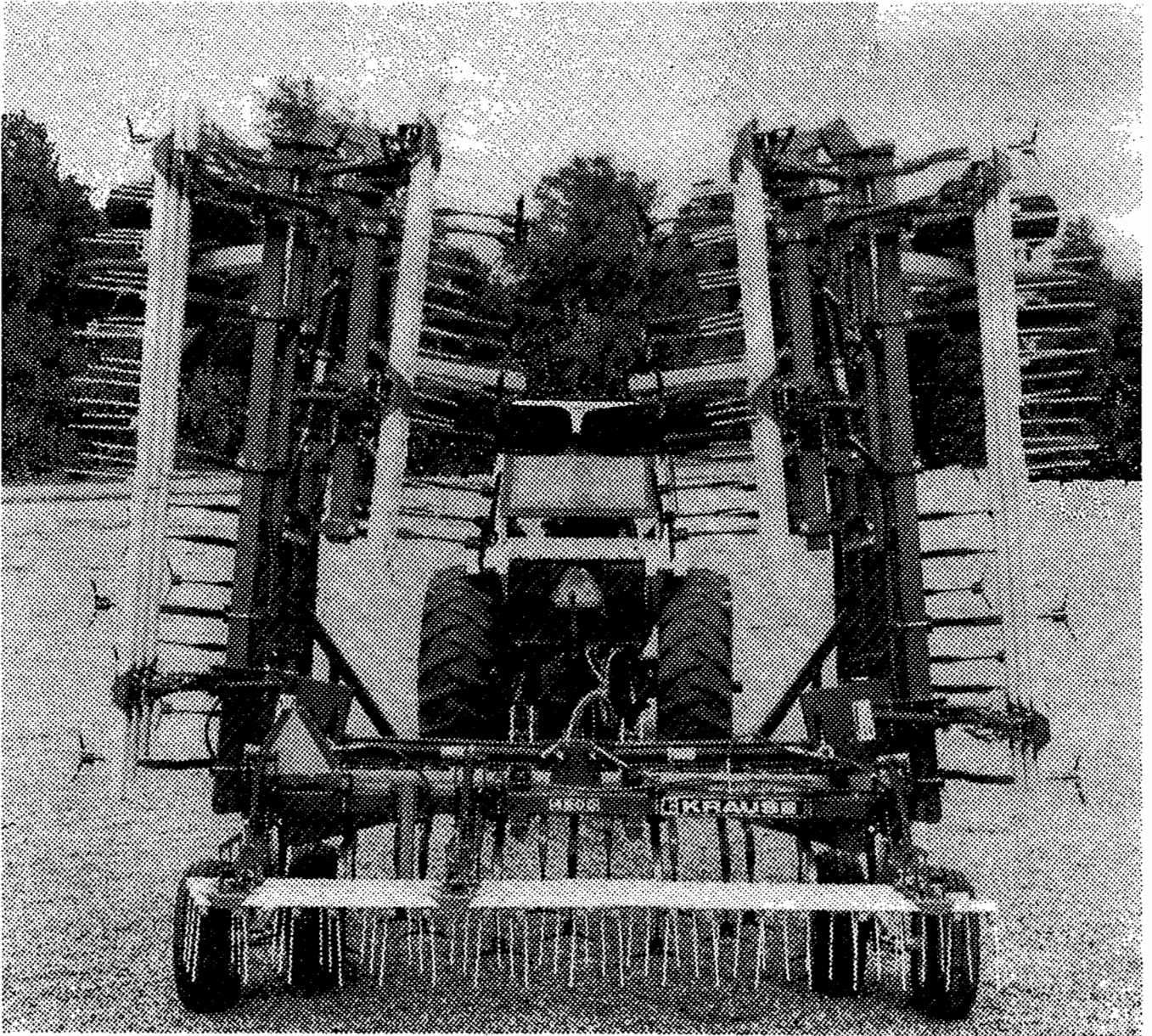

**This page intentionally left blank.**

OPERATING  
SECTION

# SAFETY ALERT SYMBOL



BE ALERT TO THE POSSIBILITY OF PERSONAL INJURY.  
THIS SYMBOL IDENTIFIES IMPORTANT SAFETY MESSAGES.  
CAREFULLY READ THE MESSAGE THAT FOLLOWS.

## TEN MOST COMMON HAND SIGNALS USED IN THE FIELD



START  
THE  
ENGINE



MOVE OUT  
OR  
TAKE OFF



MOVE  
TOWARD  
ME



SPEED  
IT UP



SLOW IT  
DOWN



THIS FAR  
TO GO



STOP



RAISE  
THE  
EQUIPMENT



LOWER  
THE  
EQUIPMENT



STOP  
THE  
ENGINE

# OPERATING INSTRUCTIONS

Elimination of the hazards listed in this manual should not be construed as providing guarantees that the equipment will meet or exceed all standards or regulations, or will be completely safe to all personnel. The operator should inspect and review the implement after it is in his possession for adequacy in safety for the function for which it will be used.



**READ ALL THE SAFETY DECALS ON THE IMPLEMENT AND REVIEW THE SAFETY FIRST SUGGESTIONS ON THE BACK OF THIS MANUAL TO REFRESH YOUR MEMORY. WATCH FOR THE SAFETY SYMBOL, AND READ THE INFORMATION THAT FOLLOWS. THIS IS FOR YOUR OWN PROTECTION.**

## ABOUT YOUR FIELD CULTIVATOR

This field cultivator has been designed for secondary tillage and is flexible enough to follow the contours of most field conditions.

It is designed to be used for control of weeds, volunteer plants, erosion control, chemical incorporation, and seed bed preparation. The field cultivator works best at speeds of 5 to 6-1/2 M.P.H., however, rocky conditions may require a slower field speed.

Horsepower requirements generally will be 2.5 drawbar horsepower, or 3.25 engine horsepower per shank.

Adding attachments should be limited to KRAUSE original equipment options, or light duty tine or spike harrows that weigh no more than 30 pounds per foot of cut. Additions of harrows will make the field cultivator "tail heavy" and the two rear parking stands should be used when the cultivator is parked or stored. (See "Hitching and Unhitching")

## PREPARING THE FIELD CULTIVATOR FOR OPERATION



**TAKE A LOOK**

1. WING LOCK PINS
  - a. Place the wing lock pins in the storage holes and unfold the wings.
  - b. With the cultivator fully raised, pin the wing depth stops in the front hole.
  - c. Support the center frame with the two rear stands and the tongue jack.
2. The wing lock pins should be stored in the wing lock storage holes and not in the clevis locking ends.
3. Check for loose bolts and tighten if needed. Check again if needed. Check again for loose bolts after the first half day of operation.
4. Check the shank locations with the Placement Drawings at the back of this manual for the model being used to be sure that the unit has been set up properly.
5. Check tire pressure. Inflate 6-Ply tires to 32 PSI and 8-Ply tires to 44 PSI. Also check the wheel lug bolts to see if they are torqued from 90 to 95 Ft. Lbs., and that the wheel hub bearings do not have excessive end play.
6. Make sure that all grease zerk locations have been sufficiently greased. Grease zerks will be found on rocker shaft bearings, depth stop assemblies, walking tandem beams, wheel hubs and wing hinges. **USE EXTREME CAUTION WHEN WORKING AROUND SHAFT SHANK POINTS & SWEEPS.**

7. Check and adjust tightness of wheel bearings before operation, after the first week and periodically thereafter. (See Service Section of this book)

## **PREPARING THE TRACTOR**

Read your tractor owner's manual. It will describe safe methods of operation. Make sure your tractor has proper added ballast, and that its hydraulic system is full of oil and working properly. Check tractor brakes and warning lights, make sure they are in working order.

## **HYDRAULIC SYSTEM**

Inspect the hydraulic system for tell-tale leaks and loose fittings. Tighten if needed. Loose tape fragments may cause cylinder valve or O-Ring leaks that can cause drifting or poor cylinder operation. Make sure a restrictor is installed in the wing lift cylinder rod end port. If not previously filled, your hydraulic system will require approximately 14 Quarts on Models 4218 and 4223, 24 Quarts on Models 4226 and 4231, or 38 Quarts on Models 4237 and 4241 of your tractor manufacturer's recommended oil. Read "HYDRAULICS" on page O14, before filling system.

When working with rephasing rocker cylinders, be sure all of the cylinders are mounted in proper sequence. Hoses must be attached in the proper order, and all air bled from the hoses and cylinders. See page O9 under REPHASING CYLINDER SYSTEM. If, after some time, one cylinder of the series should start to close for no apparent reason, oil is probably leaking past the O-Rings and an O-Ring kit, available from Krause, should be installed.

REPAIR OF HYDRAULIC CYLINDERS SHOULD BE MADE BY AN AUTHORIZED KRAUSE DEALER ONLY.

A HYDRAULIC HOSE AND CYLINDER SCHEMATIC CAN BE FOUND FOR EACH MODEL IN THIS SERIES ON PAGES P50 THROUGH P65 OF THE PARTS SECTION.

 **Caution:** Air in hydraulic system could allow field cultivator or wings to drop suddenly.

Do not operate the wing hydraulics until you have read wing lift operating instructions under "Transporting".

## **HITCHING & UNHITCHING**

 **Danger:** Do not allow any person to stand between the tractor and implement while backing into position. Sudden loss of control could cause serious injury or death to a person caught between the tractor and implement. Tell your helper to wait until you give him the signal that the tractor is in park or neutral and the hand brake is set and engine is shut off.

## Hitching To The Tractor

1. The field cultivator should be supported by the two rear stands and the tongue jack. The road lock pin is in the storage hole. The clevis spring will hold the clevis forward.
2. Unpin the tractor drawbar so it can be moved from side to side.
3. Back the tractor to the field cultivator.
4. Attach clevis **1** to tractor drawbar **2** with clevis pin **3** that fits the hole size in the tractor drawbar. Make sure pin is locked or bolted in place **4** to prevent loss.
5. Fasten safety chain and/or lights. (See "Transporting")
6. Place tongue jack in storage position.
7. Connect hydraulic hoses to tractor.
8. Raise the cultivator and engage the road lock pin.

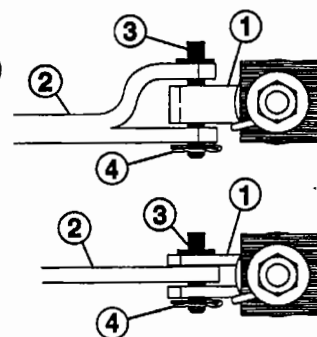
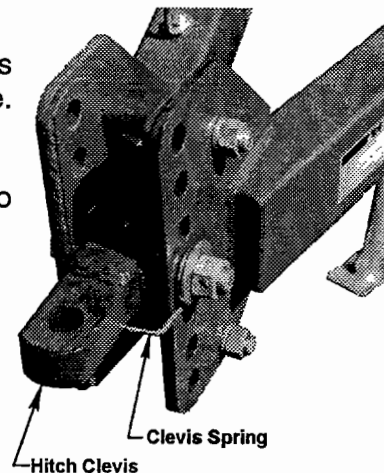

## Unhitching From The Tractor

Find a level place to park. If the field cultivator is to remain parked for storage over a long period of time, be sure to read storage suggestions on page O15.

1. To unhitch the tractor from the field cultivator, place the tractor in park or neutral and set the hand brake. If you are not parking on level ground block the implement tires.
2. Drop the two rear stands down and pin them in place.
3. Raise the unit up and remove the road lock pin. Turn off the tractor engine and relieve the hydraulic pressure until the cultivator is being supported by the two rear stands.
4. Lower tongue jack and raise the tongue height until clevis pin is loose and remove pin.
5. Disconnect the hydraulic hoses, safety chain, and lights, and the tractor may be move away.

**⚠ Caution:** Do not stand or straddle implement tongue when unhitching. If any rear attachments have been added to unit it may affect the balance of the field cultivator, causing the tongue to come up suddenly when unhitching.

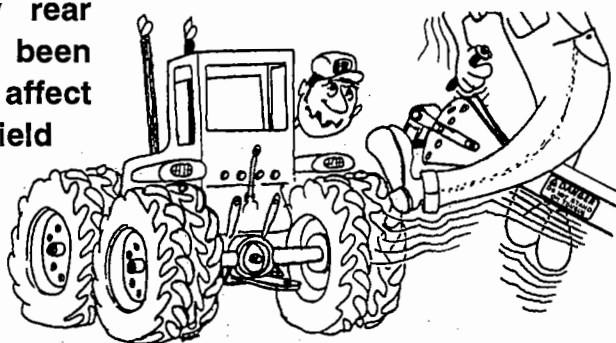

## **TRANSPORTING**

Check specification pages and be aware of transport height and width of your model of field cultivator.

**⚠ Warning:** Always use transport road locks when transporting to prevent unit from falling due to hydraulic failure, or accidental activation of the operator's control. Lowering of the tool during transporting could result in loss of control or implement and / or tractor. The tractor drawbar must always be pinned for transport.

### **Road Lock**

1. With the cultivator in the fully raised position, insert the ROAD LOCK PIN into the front hole in the center depth stop assembly. Retain it with a #4 Hair Pin Cotter.
2. Store the ROAD LOCK PIN in the storage hole provided during field operation.

**NOTE:** Machine must be up in transport position when the pin is put in the storage hole.

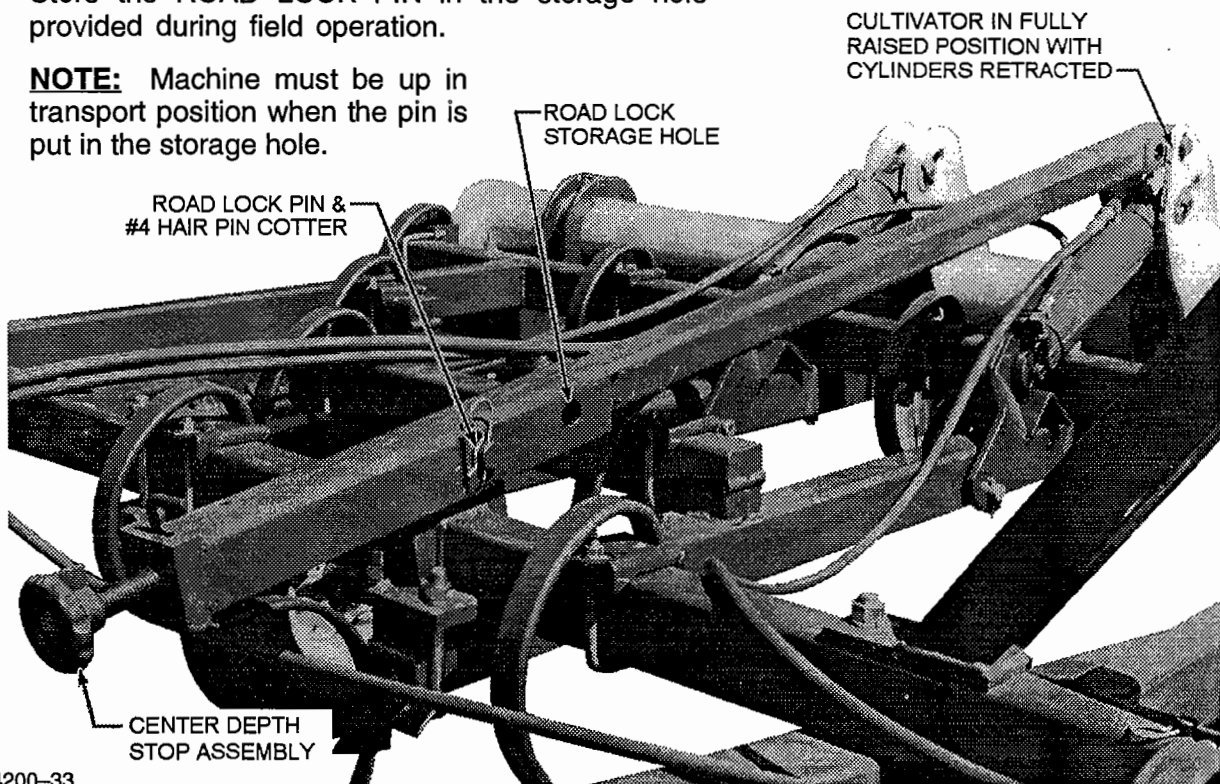

### **Raising The Wings**

The field cultivator should be in the raised position with road lock pinned. The wings will be secured in the raised position with the locking pins. Be sure the wing lock pins are in the storage holes before lifting the wings or damage to the wing frames will occur. See the illustration the follows.

**⚠ Warning:** Always stand clear of wings when they are in raised position. A hydraulic failure or activation of hydraulic controls by someone could result in serious injury to anyone under the wings.

## Lowering The Wings

Retract the wing lift cylinders to their minimum stroke. Remove wing lock pins and place in storage holes. Lower wings with all persons standing clear.

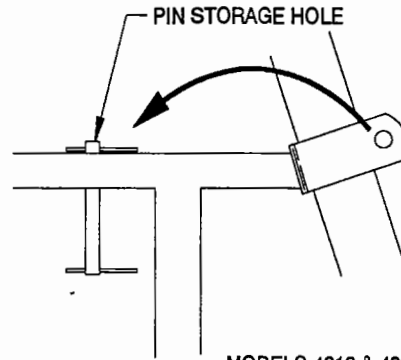
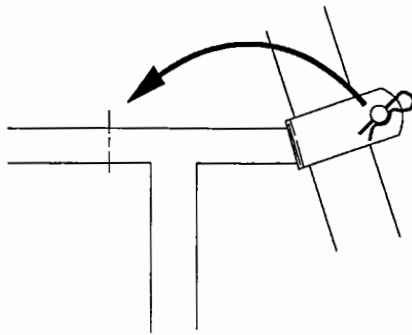

MODELS 4218 & 4223

PLACE WING LOCK PINS IN STORAGE HOLES BEFORE LOWERING WINGS

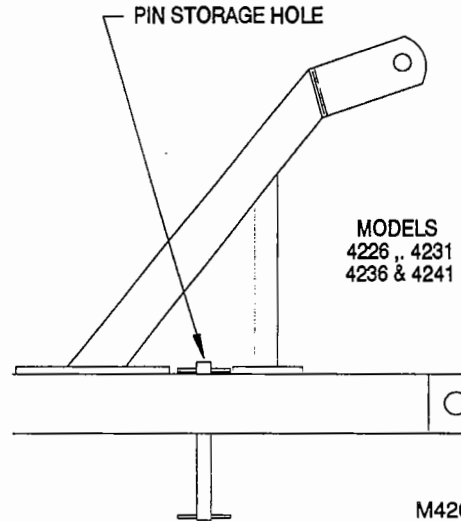
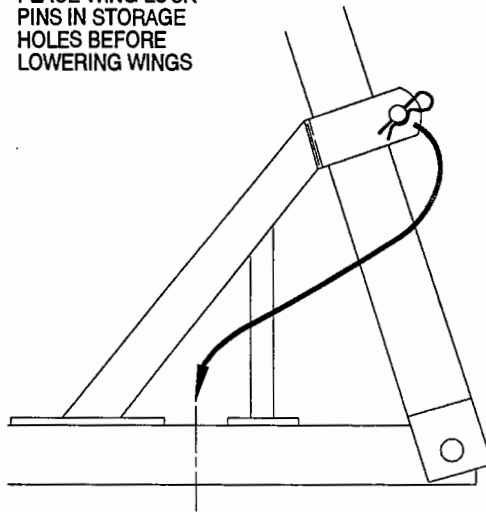

MODELS  
4226, 4231  
4236 & 4241

M4200-34

**IMPORTANT:** NEVER EXTEND WING LIFT CYLINDERS UNTIL LOCK PINS HAVE BEEN DISENGAGED, OR DAMAGE COULD OCCUR TO THE FRAME OR HYDRAULIC CYLINDER.

## Transport Safety

**Warning:** Always use a safety chain with tensile strength equal to the gross weight of the unit, plus any attachments, when transporting.

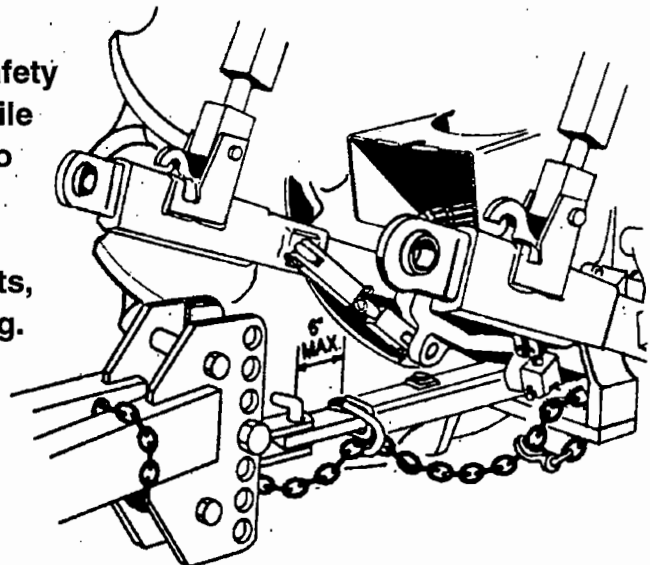

Use the ASAE Slow Moving Vehicle (SMV) emblem. The emblem is to mounted point up in a plane perpendicular to the direction of travel  $\pm 10$  degrees. It shall be placed centrally at the rear of the vehicle, unobscured, and 2' to 6' (0.61 to 1.8m) above the ground, measured from the lower edge of the emblem. The SMV emblem should be wiped clean before entering the road or highways.

Comply with state and local laws pertaining to lighting and road widths. Turn on flashing lights whenever traveling on a highway except where it is prohibited by law. If the implement obscures the tractor warning lamp, a lamp must be added to the left of the implement. Transport during daylight hours only. Watch your clearance. Be aware of obstacles along the side of the roadway that might be caught by the field cultivator when passing by. Pull over to the side of the road to permit safe clearance for oncoming traffic. Keep the red and yellow reflectors clean and visible. Replace the reflectors if they become faded or damaged. Watch for pedestrians on the side of the road that need to be warned of your presence.

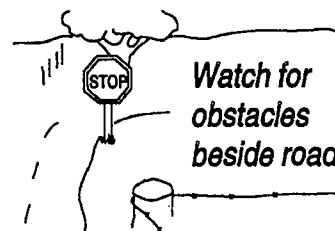

**⚠ Danger:** Always check conditions of transport lock pins, tires, wheels, hubs, safety chain, hitch bolts, and clevis pin before transporting the implement.

Be aware of the transport height as well as the width of your model of field cultivator. Care should be taken not to snag low hanging telephone lines or electrical service lines.

It is best to use a tractor to transport the field cultivator to another location. If using another type of towing unit it should never be allowed to exceed 15 M.P.H., since implement tires are not constructed to be operated at higher speeds. The towing vehicle should always equal or exceed the gross weight of the field cultivator and attachments.

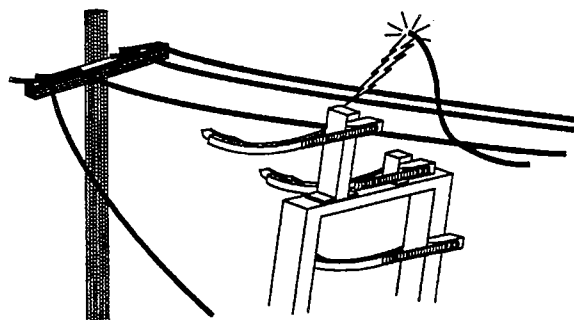

Always check the tire pressure before transporting and look for damaged tires. Wobble the tires from side to side. If excessive play is noted, adjust the hub spindle nut before roading to prevent damage to the hub or bearings.

**⚠ Caution:** It is very important to check wheel lug bolts after the first half mile of initial transport (delivery). If loose, tighten to 90 to 95 Ft. Lbs. torque. Continue to check frequently until they remain firmly seated.

### Hitch Pin

Use the proper size hitch pin with a means for holding it in place so it cannot work itself out during transport. The hitch pin should be inspected for wear or cracks before using it to transport your field cultivator.

## FIELD ADJUSTMENTS

The center and wing frames should have been leveled from side-to-side during cultivator assembly. (See pages A36, and A37 in the Assembly Section)

Check the center DEPTH CONTROL KNOB and make sure it is screwed on the stop bolt the right amount. If it is not, remove the roll pin and adjust the to the dimension shown below.

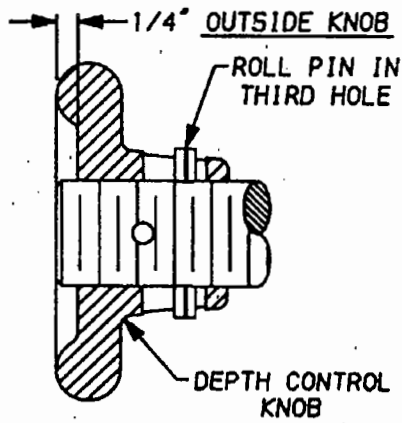

CENTER SECTION  
WITH WALKING BEAM  
DUAL WHEELS

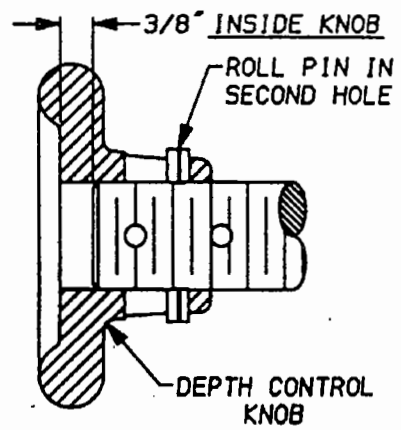

CENTER SECTION  
WITH  
SINGLE WHEELS

## UNDERSTANDING YOUR DEPTH CONTROL SYSTEM



The 4200 Series Field Cultivator uses a mechanical depth stop system. This eliminates the problem of depth change due to cylinder leaks because it does not depend on oil under pressure to gauge depth. Accuracy, reliability and ease of adjustment are inherent in this design.

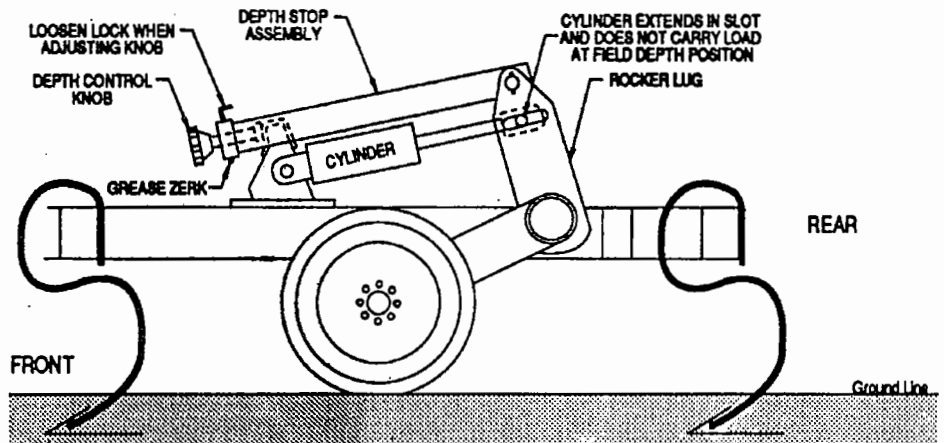

This is how the depth control works:

1. Rephasing cylinders extend to lower the cultivator into the ground.
2. The depth stop assembly stops the rocker rotation at the desired depth.
3. The rephasing cylinders continue to extend freely into a slot in the rocker lug.

### Depth Adjustment Procedure

1. Raise the cultivator out of the ground to relieve depth stop pressure.
2. Rotate the Depth Control Knob **counter-clockwise** to **increase** depth; rotate the Depth Control Knob **clockwise** to **decrease** depth.

NOTE: All rocker depth stops must be adjusted the same number or rotations to maintain a level unit.

A decal has been provided to let you know how many turns are necessary for any given change in depth.

**IMPORTANT:** THE CULTIVATOR WILL ONLY BE LEVEL WHEN IT IS LOWERED DOWN AGAINST THE DEPTH STOPS.

WHEN THE CULTIVATOR IS RAISED HYDRAULICALLY OFF OF THE DEPTH STOPS, IT MAY NOT MAINTAIN A CONSISTENT DEPTH.

### Leveling From Front To Rear

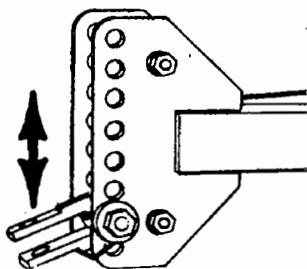

Stop with the cultivator still in the ground. Stand at a reasonable distance and view the frame and tongue to determine if they are level from front to rear. If the frame is not level, adjust the hitch clevis up or down as required using the holes provided in the hitch plate. The jack mounted on the tongue will aid in making this adjustment. Pull the field cultivator forward a few feet, dismount from the tractor and re-check to be sure the implement is now level from front to rear. Re-level if necessary.

### Leveling The Frames From Side To Side

Although the frames have been leveled during assembly, it will probably need fine tuning in the field because of cultivator tires running in tractor tracks.

#### IF WING IS HIGHER THAN THE CENTER SECTION:

1. Raise the cultivator with tractor hydraulics to remove pressure from the depth stops.
2. Rotate the wing depth control knob counter-clockwise one or two turns.
3. Operate the cultivator with cylinders fully extended. If the wing is still too high, repeat steps a and b above.

#### IF WING IS LOWER THAN THE CENTER SECTION:

1. Raise the cultivator with tractor hydraulics to remove pressure from the depth stops.
2. Rotate the wing depth control knob clockwise one or two turns.
3. Operate the cultivator with cylinders fully extended. If the wing is still too low, repeat steps a and b above.

When the frames are running level, stop the cultivator in the ground with pressure on the depth stop assemblies.

Remove the roll pin in the wing depth control knob and adjust the knob in the same manner as the center depth control knob.

Replace the roll pin.

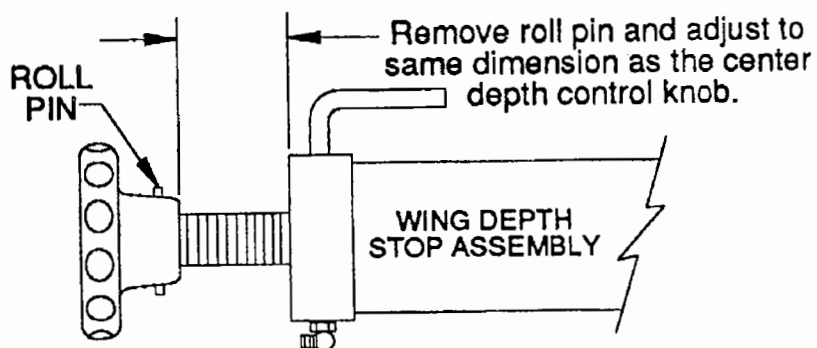

## Understanding Your Rephasing Cylinder System

When the cultivator is raised completely out of the ground these specially designed cylinders are rephased for uniform lifting by holding the tractor remote hydraulic control lever in the raised position for 20 to 30 seconds. This allows a small volume of oil to bypass the piston seals. Consequently, all of the cylinders can be fully retracted.

**MODELS  
4218 & 4223**

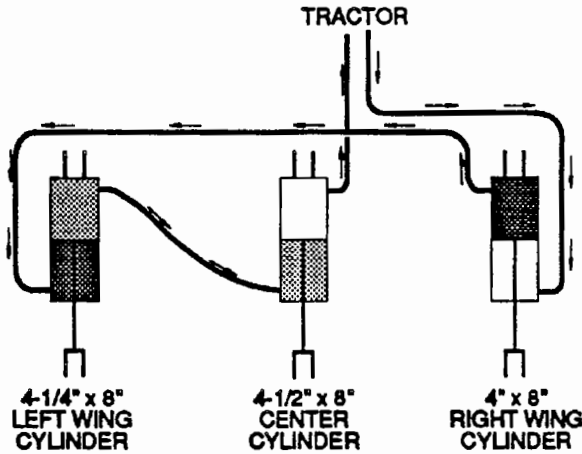

**REPHASING CYLINDERS  
PLUMBED IN SERIES**

**NOTE: ARROWS SHOW OIL FLOW TO  
RETRACT CYLINDERS AND  
RAISE CULTIVATOR**

**MODELS  
4226, 4231  
4237 & 4241**

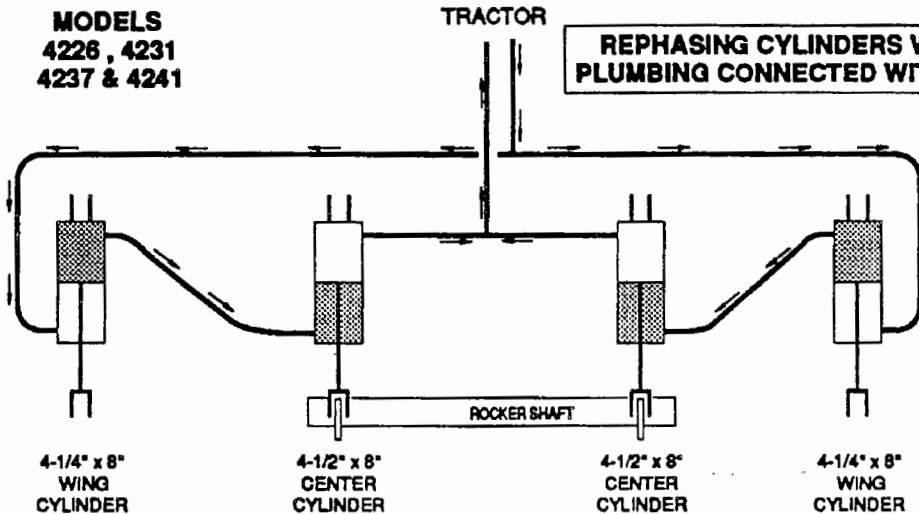

**REPHASING CYLINDERS WITH DUAL SERIES  
PLUMBING CONNECTED WITH CENTER ROCKER**

**NOTE: ARROWS SHOW OIL FLOW TO  
RETRACT CYLINDERS AND  
RAISE CULTIVATOR**

**WING CYLINDER NOT  
IN PHASE WITH  
CENTER CYLINDER.**

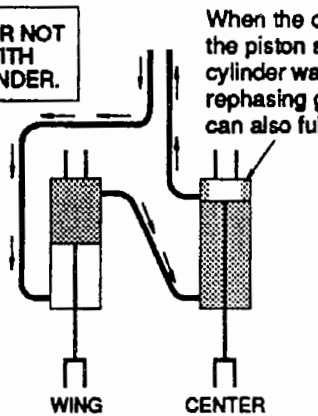

**REPHASING PROCESS**

When the cylinder is fully retracted, oil can flow around the piston seal through the rephasing grooves in the cylinder wall. As the oil continues to be forced past the rephasing grooves, the other cylinders in the system can also fully retract

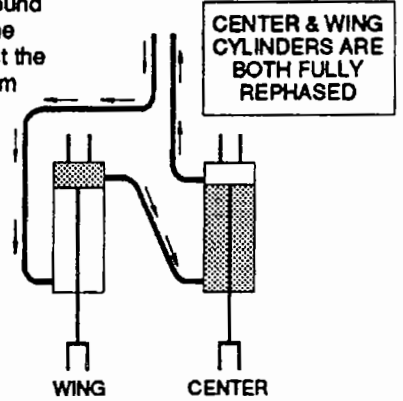

**CYLINDERS REPHASED**

## Flexibility

**ALWAYS WORK WITH THE WINGS DOWN:** Major damage may occur to shanks and frame members if used with the wings up. For maximum flexibility, make sure the wing hydraulic cylinders are fully extended after the wings are down.

When working terraced ground, place the wing up on the terrace, not down over the terrace, as the wing is limited in its downward movement, but not as much in its upward movement.

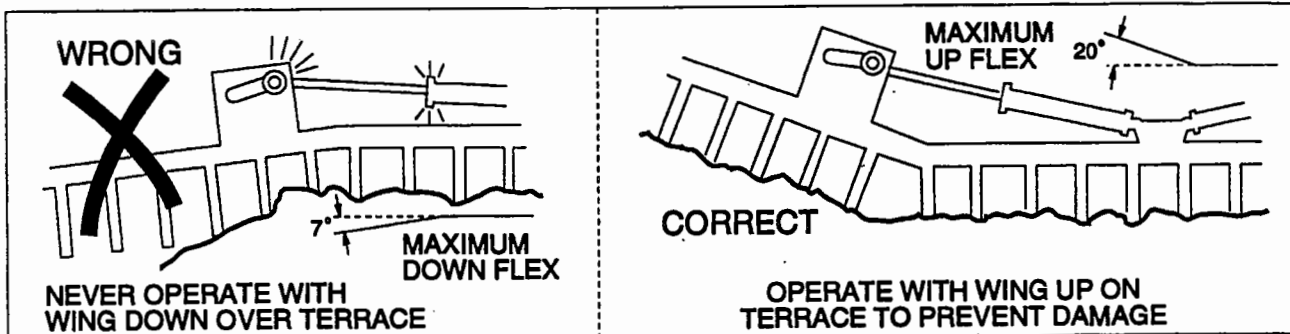

## Turning In The Field

Short turns at working depth may result in driving the outside shanks deeper in the ground, causing damage to shanks or frame members. If short turns must be executed, raise the field cultivator out of the ground and complete the turn before engaging the tool for further tilling.

When lifting the field cultivator completely out of the ground, hold the tractor hydraulic valve open for a second or two to resynchronize the slave cylinders.

See section "UNDERSTANDING YOUR REPHASING CYLINDER SYSTEM" on page O9.

## Field Speed

While high field speed of around 6-1/2 M.P.H. may be recommended for weed killing purposes in light soil and shallow depth, a slower speed is recommended for heavy soils and deep work. Slower speed will also add life to field cultivator points and sweeps.

## GENERAL INFORMATION

Points are recommended for light soils and when higher ridges are desired. Sweeps are for light draft cultivation and not for deep work.

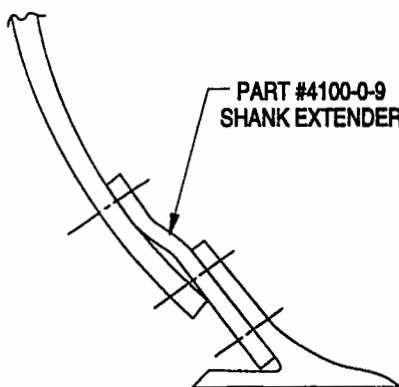

**LOWERS DEPTH 1"**

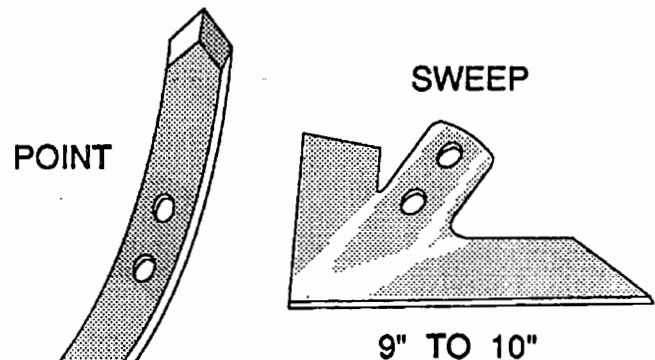

47 Degree Stem Angle on C-Shanks  
43 Degree Stem Angle on K-Tines  
47 Degree Stem Angle on 2-Piece K-Tines

Sweeps with a 47 degree stem angle are recommended on units with C-Shanks, or 2-Piece K-Tines. 43 degree sweeps are recommended when the unit is equipped with K-Tines.

Shank Extenders (Part number 4100-0-9) are for use on C-Shanks and K-Tines, located in back of the tractor tires, to lower the depth of the shanks by approximately 1".

**⚠ Danger:** The wing mounted shanks and points can seriously injure anyone that gets too close. Never under any circumstances should anyone be allowed to walk or work under a wing that is in the raised transport position.

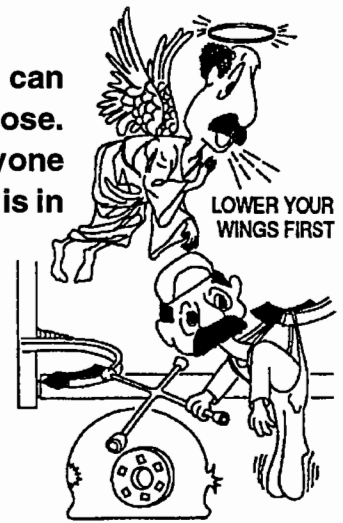

## **SERVICING**

### **General Maintenance**

All nuts should be checked and tightened during and after the first 1/2 day of operation, and periodically thereafter. Keep tires inflated to the recommended pressure, and check the wheel bolts until they are firmly seated. Hydraulic hoses should be checked for wear and pinched areas and replaced if necessary. Check shanks and mountings for breaks and turn or replace points when worn.

NOTE: When turning or replacing points, be sure to turn or replace all of the points.

**⚠ Warning:** Raise the cultivator and make sure that the center road lock and wing depth stops are pinned in front holes before working around cultivator point or sweeps.

### **Lubrication**

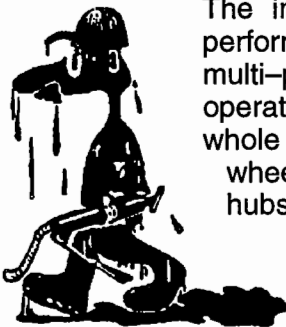

The initial lubrication of all grease fittings will assure long life and satisfactory performance from the field cultivator. Minimum lubrication is required. Use a multi-purpose type grease at all grease zerk locations after each 24 hours of operation. Rocker shaft bearing clamps will accept grease more efficiently if the whole unit is lowered to the ground with the weight of the unit removed from the wheels. points of lubrication are: wing hinges, walking tandem bearings, wheel hubs, and depth stop assemblies.

**FOR YOUR SAFETY: WHEN LUBRICATING OR ADJUSTING YOUR FIELD CULTIVATOR, WATCH FOR OBSTRUCTIONS AND PROTRUSIONS. LOWER IMPLEMENT WINGS TO THE GROUND AND ENTER FRAMEWORK BY STEPPING OVER. DO NOT WALK ON TIRES.**

### **Wheel Bearings**

Grease wheel bearings every 24 hours of use. Check for excessive end play each time bearings are greased. Once a year, clean and repack wheel bearings with EP#2 Grease. Replace seals each time bearings are removed. Replace any worn or damaged parts. After repacking, replace hub with seal and rear bearing already assembled. Use light oil on seal surface and use extreme care when pushing seal over the spindle. Install outer bearings, flat washer, and slotted nut. Tighten nut while turning hub until there is resistance to rotation. Then back off nut from 1 to 2 slots until hub turns freely without end play. Secure nut with clinched cotter pin.

### **Walking Beam Maintenance**

Grease walking beam bearings every 24 hours of use. Check, clean, and repack walking beam bearings each year in a procedure similar to that of wheel bearings.

When reassembling the walking beam, tighten the slotted axle nut in until there is a 5 to 10 ft. lb. preload on the bearings. Do not back the axle nut off.

## Folding Extensions

Do not work your field cultivator with the extension left in the folded position. When the unit is lowered into the ground, the tires will come up and strike the extensions and damage the tires. If folding of extensions is not required, they can be bolted rigid to the wings using 3/4NC x 3-1/2" Cap Screws, Flat & Lock Washers, and Hex Nuts.

## Spring Shank Repair

Check shanks periodically for loose bolts and nuts, at this time check for broken springs.

To replace a broken spring, first attach a (Part # 4122-0-14) Winch Bracket to the upper sweep boot, attach a chain to this bracket and around the cultivator frame. Pull up on the shank until the roll pin is free. See Figure 1.

Remove roll pin, lower shank and replace broken spring. See Figure 2.

Guide spring rod through slot in the mounting channel with a screwdriver. See Figure 3.

Replace square washer and roll pin. Remove the winch and the 4122-0-14 winch bracket, store bracket on a spring shock clamp bolt.

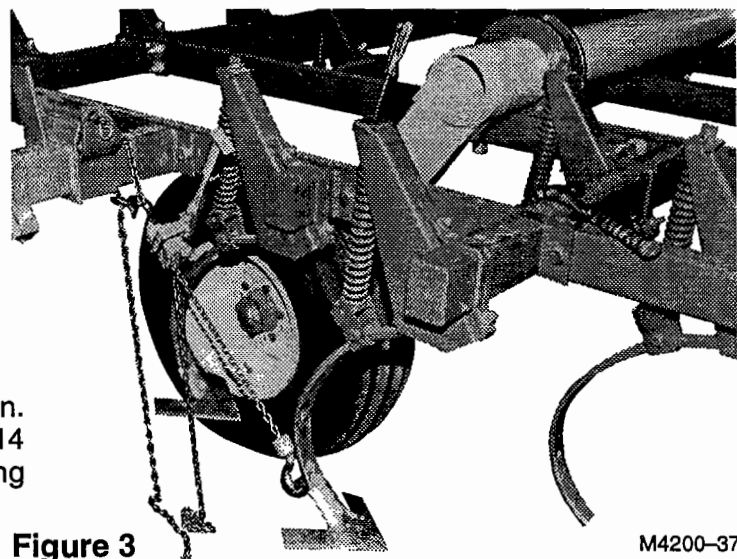
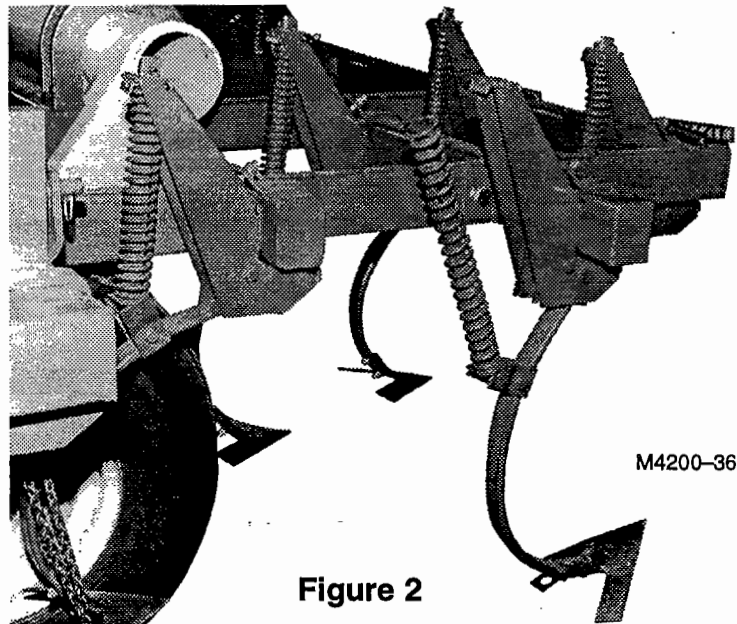
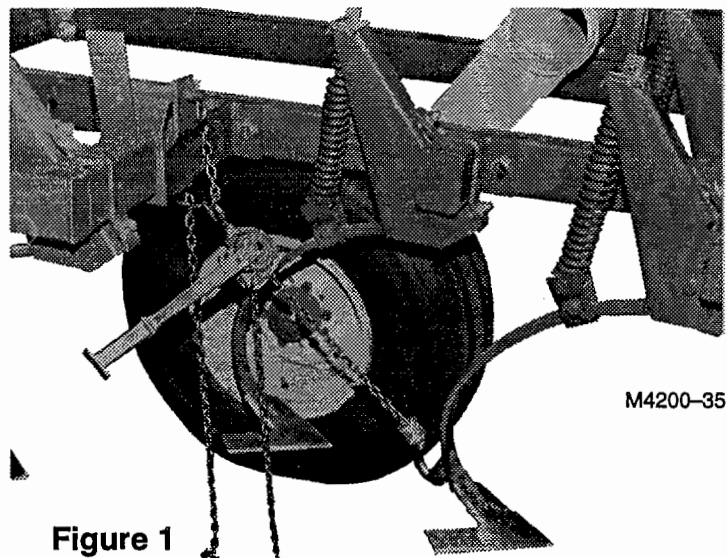

## **MODELS 4237 AND 4241 WING FOLD SEQUENCE VALVE**

Models 4237 and 4241 are full 5-Section field cultivators, which use a sequence valve to cause the inside wing to unfold before the outside wing unfolds.

**IMPORTANT:** THE INSIDE WINGS SHOULD UNFOLD COMPLETELY BEFORE THE OUTER WINGS BEGIN TO UNFOLD. IF IT DOES NOT LET THE INSIDE WING COMPLETELY UNFOLD, CHECK AND / OR CORRECT AS DESCRIBED BELOW.

<u>POSSIBLE CAUSE</u>	<u>REMEDY</u>
1. 25-324 In-Line Restrictor is not plumbed in correct place	Correct hydraulic plumbing as shown on pages A34 and P55-P57.
2. Sequence Valve is not set properly	a. Fold outer wing only b. Increase sequence valve pressure until wing cannot be unfolded. c. Decrease valve pressure only enough to allow outer wings to unfold.
3. Internal leaks in valve	Replace valve

** Warning: Always stand clear of wings when they are in the raised position. A hydraulic failure or activation of hydraulic controls by someone could result in serious injury to anyone under the wings.**

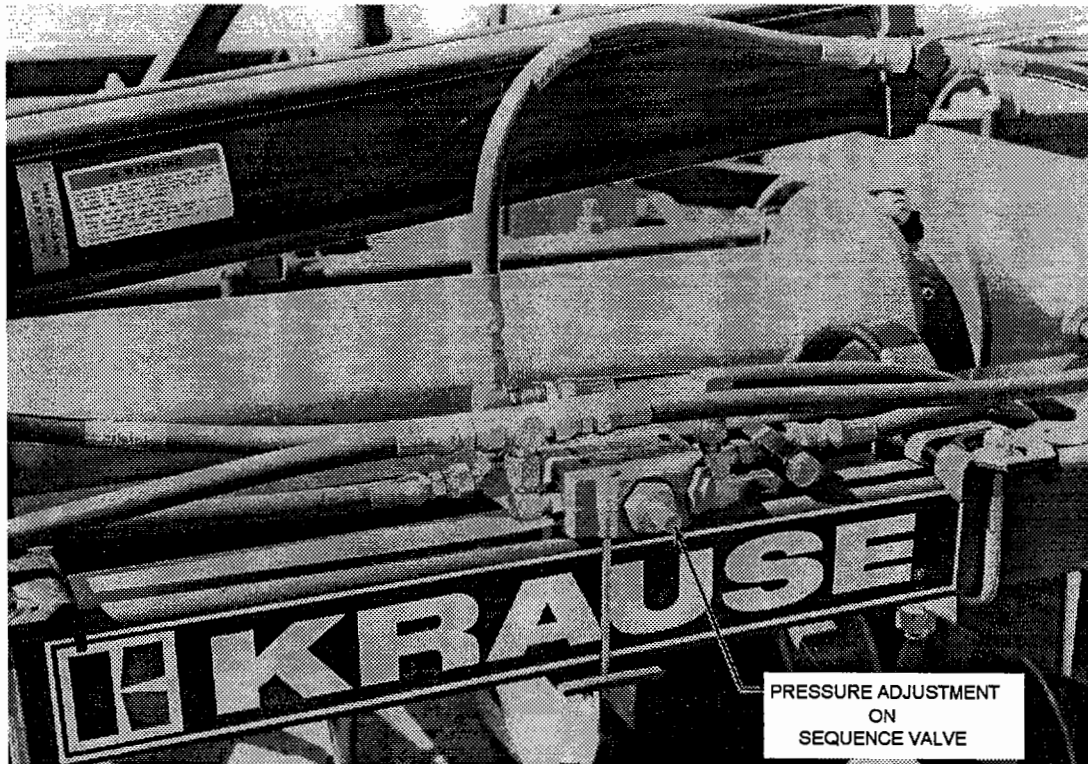

M4200-38

# HYDRAULIC SAFETY

## PLEASE READ CAREFULLY

If the implement hydraulic system has never been used, stored over a period of time or disassembled for any reason, unpin the rod ends of the cylinders and support the cylinders so the rod ends will clear frame members when fully extended. Back the tractor to the front of the implement and connect the hydraulic hoses. Check the tractor hydraulic reservoir and make sure it is full of the manufacturer's recommended oil. If you are sure the implement hydraulic hose connections are tight, begin filling the system by extending and retracting the cylinders. Hold the control lever open and pause at the end of each stroke to bleed the air from the system. Continue the cycles until the cylinders respond with immediate solid actuation. When you are sure the systems are free of air, pin the rod ends of the cylinders to the implement cylinder lugs.

**Warning:** Escaping fluid under pressure can penetrate the skin causing serious injury. Avoid the hazard by relieving pressure before disconnecting hydraulic lines. Tighten all connections before applying pressure.

Search for leaks with a piece of cardboard. Protect hands and body from high pressure fluids.

If an accident occurs, see a doctor immediately. Any fluid injected into the skin must be surgically removed within a few hours or gangrene may result.



### AVOID HEATING NEAR PRESSURIZED HYDRAULIC HOSES

Flammable spray can be generated by heating near pressurized hydraulic hoses, resulting in severe burns to yourself and bystanders. Do not heat by welding, or using a torch near hoses. Hose can be accidentally cut when heat goes beyond the immediate flame area.

### THE FOLLOWING WARNINGS PERTAIN TO THE MORE COMMON ABUSES OF HYDRAULIC HOSE:

1. **INSPECT** the hose assembly before each use.
2. **REPLACE** the hose assembly immediately if:
  - a. The jacket of the hose appears abnormal.
  - b. You have reason to believe it may be abnormal.
  - c. There is any fluid leakage.
  - d. The couplings are damaged.
  - e. The hose is damaged or kinked.
  - f. The reinforcement is visible through the jacket.
3. **DO NOT EXCEED** the maximum recommended working pressure of the hose.
4. **DO NOT KINK** the hose assembly.
5. **DO NOT BEND** the hose assembly beyond its minimum recommended bend radius of 3.25 in.
6. **DO NOT EXPOSE** to temperatures in excess of 225° Fahrenheit.
7. **DO NOT USE AS A STRENGTH MEMBER** for pulling or lifting equipment.

**Caution:** If replacing hydraulic hose, use only hose that meets or exceeds 3,000 PSI working pressure.

IMPORTANT: REPAIR OF HYDRAULIC CYLINDERS SHOULD BE MADE BY AN AUTHORIZED KRAUSE DEALER.

Prevent damage to trail hoses by supporting them from the tractor with an elastic strap "A". Avoid having excess hose between the implement support "B" and the tractor connection "C". Either reposition the hose farther back on the implement or request a shorter hose from your dealer.

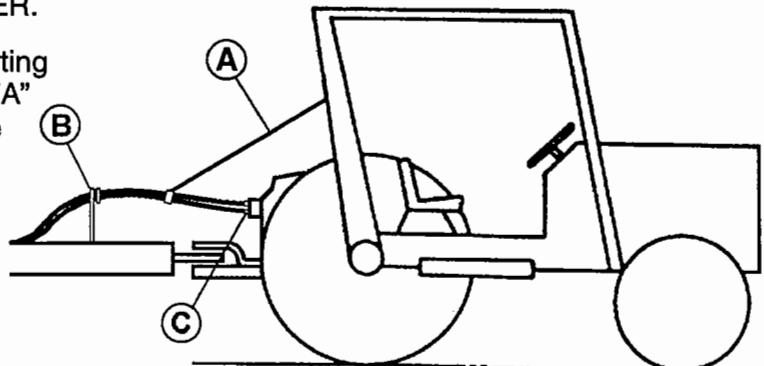

## Storage

Select a level area, lower the wings and set the field cultivator down on blocks to prevent points from settling into the ground. Retract the gauge wheel hydraulic cylinder. Coat sweeps and wing lift cylinder rods with rust preventative. Inspect for worn or damaged parts and replace as needed to avoid delays the next season. Check to be sure hydraulic hose couplers are stored on top of the tongue and not left laying on the ground.

## Repair Parts

Refer to the Assembly Section of this book when repairing or replacing parts, and follow the same procedure as used when assembling a new unit. Reverse this procedure for disassembly. The Parts Section of this book will show a breakdown of assemblies, location of parts and part numbers.

KRAUSE parts were developed and tested for these units, therefore, it is recommended that KRAUSE replacement parts be used.

**⚠ Caution:** If replacing hydraulic hose, use only hose that meets or exceeds 3,000 PSI working pressure.

**⚠ Caution:** Explosive separation of a tire and rim parts can cause serious injury or death.

Always maintain the correct tire pressure. Do not inflate the tires above the recommended pressure. Inspect tires and wheels daily. Do not operate with low pressure, cuts, bubbles, damaged rims or missing lug bolts and nuts.

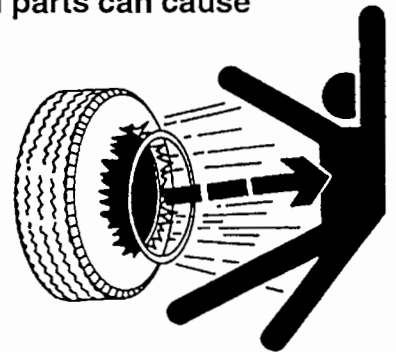

**IMPORTANT:** REPAIR OF HYDRAULIC CYLINDERS SHOULD BE MADE BY AN AUTHORIZED KRAUSE DEALER ONLY.

## SUGGESTED REMEDIES FOR POSSIBLE FIELD PROBLEMS

PROBLEM	POSSIBLE CAUSE	SUGGESTED REMEDY
Plugging	Straw is dragging	Work deeper
	Bunched trash	Work shallow the first time
	Field is too wet	Allow field to dry
	Shanks positioned wrong	Recheck shank spacing
Not level from front to rear	Clevis height not adjusted when depth changed	Use wheels to gauge depth and adjust clevis height with unit in working position
	Some weight of unit not on wheels during leveling adjustment	Use wheels to gauge depth and adjust clevis height with unit in working position

PROBLEM	POSSIBLE CAUSE	SUGGESTED REMEDY	
Excessive Ridges	Loose point or sweep bolts	Tighten plow bolts or replace if missing	
	Improper shank spacing or shanks located wrong	Measure and relocate. If shank is shifting on frame, make sure shank is straight front to back when tightening hex nuts	
	Frame not level	Level frame at operating depth as described in operating instructions	
	Bent shank	Straighten or replace shank	
	Sweeps with old residue will cause soil build-up preventing necessary scouring for even flow	Remove trash and residue. Clean field cultivator after operation. Use rust preventative before storing	
Field cultivator will not lower	Road lock	Extend depth cylinders; unpin road lock	
	Hose couplers not locked in tractor sockets	Check hydraulic hose connectors	
	Oil not flowing through system	Plugged line or cylinder	Look for restrictor ell in rocker cylinder plumbing. Replace with STD. 90° ell.
Field cultivator does not follow directly behind tractor	Points are different length	Replace or turn	
	Bent shanks	Replace or straighten shanks	
	Wings out of adjustment	Readjust wing depth stop assemblies. See pages O7 and O8	
	Bent rocker shaft	Replace or straighten	
	Tire size or air pressure	All tires should be within $\pm 1/2$ " diameter	
		All tires should have same air pressure. See Specification page	
	Shank locations wrong	Check shank spacing. Correct if needed.	
		Check shank locations. Relocate correctly. See placement pages.	
Cultivator not lowered down against depth stops	Lower cultivator against stops or readjust stops. See page O7		
Slave cylinder out-of-phase	Raise unit out of ground. Hold control lever open until cylinders are completely retracted.		
Center section not level from side to side	Incorrect tire pressure	Check tire pressures. 9.5L x 15 6-Ply 32 PSI, 11L x 15 6-Ply 32 PSI, 9.5L x 15 8-Ply 44 PSI	
	Bent/ twisted rocker shaft/wheel arm	Replace or straighten	
	Bent frame	Replace or straighten	

PROBLEM	POSSIBLE CAUSE	SUGGESTED REMEDY
Wings not level from side to side	Wing too high	To lower wing; adjust wing depth stop. See pages O7 and O8
	Wing too low	To raise wing; adjust wing depth stop. See pages O7 and O8
	Wing lift cylinders not fully extended	Extend cylinder to maximum length; hold open briefly
	Slave cylinders out of phase	Raise unit out of ground, hold control lever open until cylinders are completely retracted
Wings will not raise to transport position	Wing lift cylinder restrictors plugged	Remove, check & clear any foreign material that might plug small orifice in restrictor at rod end of cylinders
	Insufficient hydraulic pressure	Check tractor hydraulic system
Wings will not lower	Wings are locked with pins	Unpin BOTH wings
	Hose couplers not locked in tractor disconnect socket	Check hydraulic hose connectors
Wheels have excessive wobble	Loose wheel bolts	Torque wheel bolts from 90–95 Ft. Lbs.
	Loose spindle nut	Tighten spindle nut, turn back one notch and pin
Settling or continually going deeper while working	Cultivator not lowered down against depth stops	Lower cultivator against depth stops; See page O7
		Readjust stops to shallower setting
Wings will not flex down	Wing lift cylinders not fully extended	Extend wing lift cylinders to max. length
Field cultivator will not penetrate	Sweeps have wrong angle	Use 47° stem angle for spring shanks and 2-piece K-tine shanks. Use 43° stem angle for one-piece K-tine shanks.
	Ground is too hard	Wait for moisture
	Dull points	Replace or turn over
	Excessive field speed	Slow to 5 MPH or less
	Cultivator not set deep enough	To increase depth; lower all depth stops See page O7

**\* IMPORTANT: DO NOT REMOVE SHANKS**

\* NOTE: Removing shanks to obtain additional depth will cause the remaining shanks, and frame members on which these shanks are mounted to be overloaded. This could cause bent shanks, broken bolts or clamps, or twisted frame members.

**This page intentionally left blank.**



# **PARTS SECTION**

THE FOLLOWING ILLUSTRATED PARTS SECTION HAS BEEN COMPILED TO REFLECT PART NUMBERS REQUIRED TO ORDER PARTS, AND TO SUPPORT THE ASSEMBLY SECTION FOR DIMENSIONS AND DESCRIPTIONS OF ALL PARTS, BOLTS, PINS, ETC. THE OPERATOR CAN ALSO IDENTIFY PART NAMES TO CLARIFY PROPER OPERATIONAL STEPS.

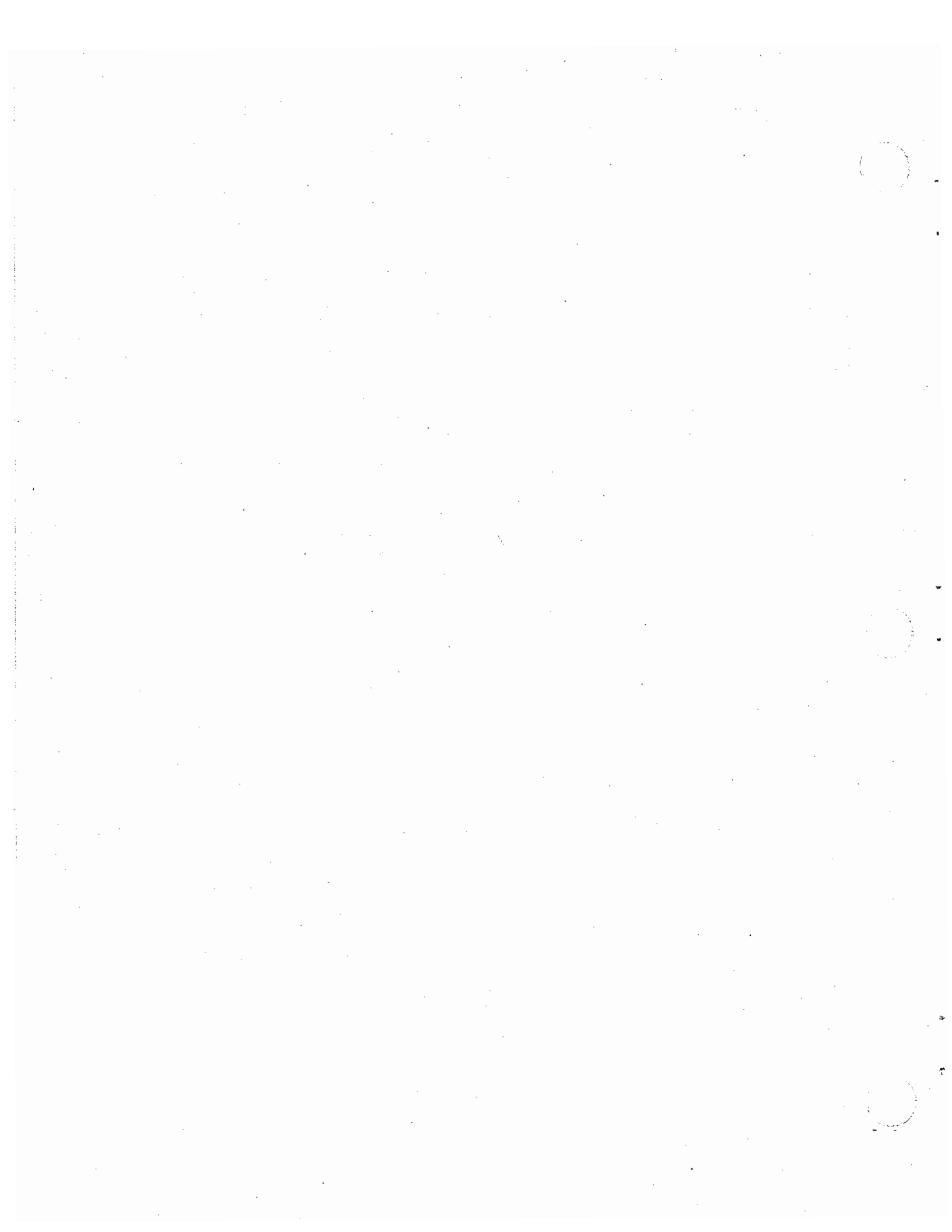

# Notes



A series of horizontal lines for writing notes, spanning the width of the page.



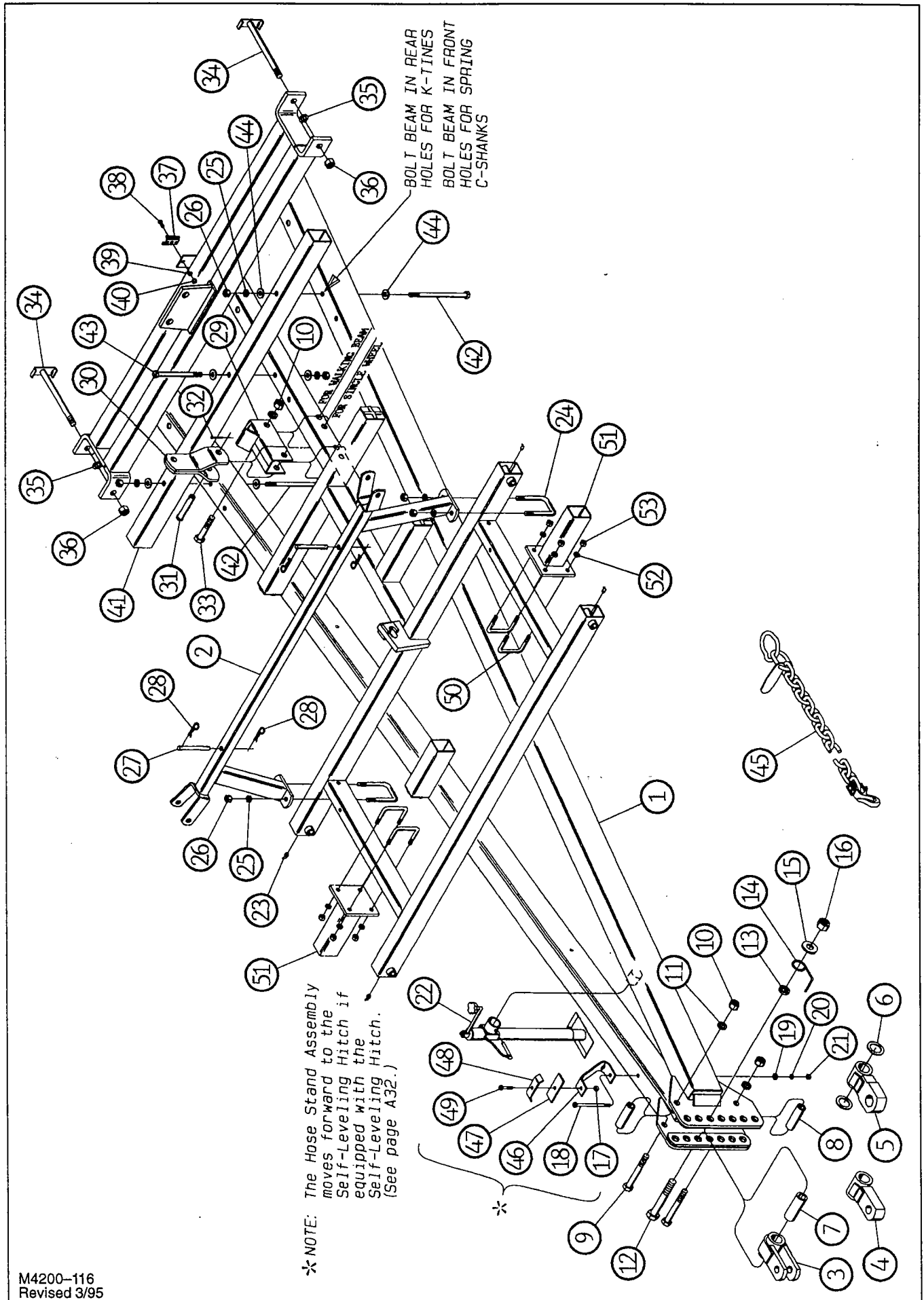

# MAIN FRAME ASSEMBLY

FOR MODELS – 4218, 4223

3/95

Item	Part Number	Part Description	Qty.
1	4223-1-0C	Main Frame Weldment	1
2	4218-20-0A	Wing Lock Weldment	1
3	770-85-0	Clevis Weldment (Standard)	1
4	770-86-0	Crawler Clevis Weldment (Optional)	1
5	1330-54-0	Crawler Clevis Weldment (Optional)	1
6	64-154	Machinery Bushing (for 1330-54-0)	2
7	1520-0-15	Hitch Tube	1
8	2330-0-5	Spacer Tube	2
9	62-254	1NC x 7-1/2" Cap Screw	2
10	63-117	1NC Hex Nut	3
11	64-118	1" STD. Lock Washer	3
12	62-277	1-1/4NC x 8" Cap Screw	1
13	1901-0-21	Bushing	1
14	76-119	Clevis Spring	1
15	64-126	1-1/4" STD. Flat Washer	1
16	63-126	1-1/4NC Self Locking Nut	1
17	★ 63-108	1/2NC Nylon Top Lock Nut	1
18	★ 62-161	1/2NC x 7" Cap Screw	1
19	★ 64-108	1/2" STD. Flat Washer	3
20	★ 64-107	1/2" STD. Lock Washer	1
21	★ 63-106	1/2NC Hex Nut	1
22	73-100	Jack Assembly	1
23	65-100	1/8NPT x 45 degree Zerk	4
24	61-207	3/4" DIA. U-Bolt	2
25	64-112	3/4" STD. Lock Washer	4
26	63-112	3/4NC Hex Nut	4
27	1505-0-5	Wing Lock Pin	2
28	60-716	#3 Hair Pin Cotter	4
29	4223-29-0	Stop Weldment	1
30	4226-29-0	Cylinder Lug Weldment	1
31	60-225	1" DIA. x 5" Clevis Pin	1
32	60-704	3/16" DIA. x 2" Cotter Pin	1
33	62-245	1NC x 5" Cap Screw	1
34	4218-42-0	Hinge Bolt Weldment	2
35	64-141	Special Washer (1-3/4 x 1-1/16 x 7 Ga)	2
36	63-119	1NC Self Locking Nut	2
37	74-144	Socket Lamp Bracket	1
38	62-131	7/16NC x 1" Cap Screw	1
39	64-105	7/16" STD. Lock Washer	1
40	63-104	7/16NC Hex Nut	1
41	4223-0-3	Shank Box	1
42	62-227	3/4NC x 12" Machine Bolt	2
43	62-221	3/4NC x 9" Machine Bolt	1
44	64-113	3/4" STD. Flat Washer	6
45	72-351	#10,000 Safety Chain	1
46	★ 4901-0-12	Hose Stand	1
47	★ 2145-170-5	Hose Plate	1
48	★ 2426-170-5	Hose Clamp	1
49	★ 62-142	1/2NC x 2" Cap Screw	1
50	61-195	5/8" DIA. U-Bolt (For 2 x 4 Box)	4
51	4236-26-0	12" Shank Extension Weldment	2
52	64-109	5/8" STD. Lock Washer	8
53	63-109	5/8NC Hex Nut	8

★ Shown mounted in holes for Single Wheels. Rear set of holes are for Walking Beams.

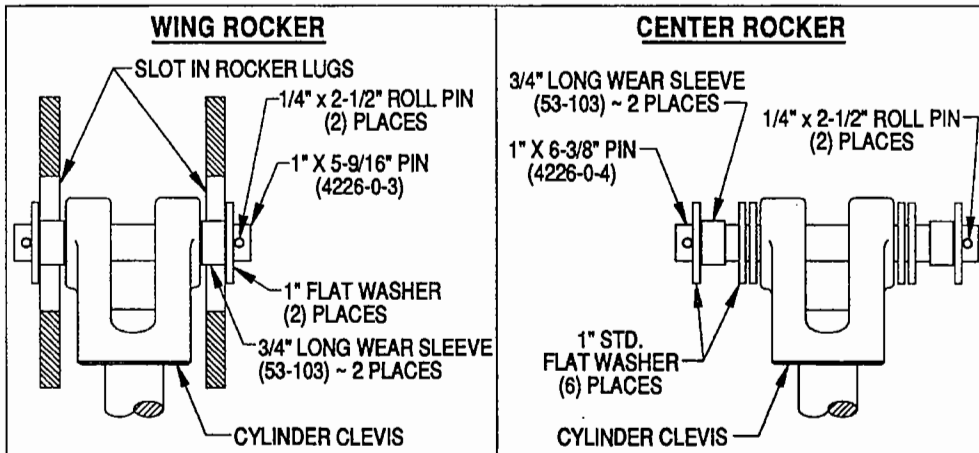
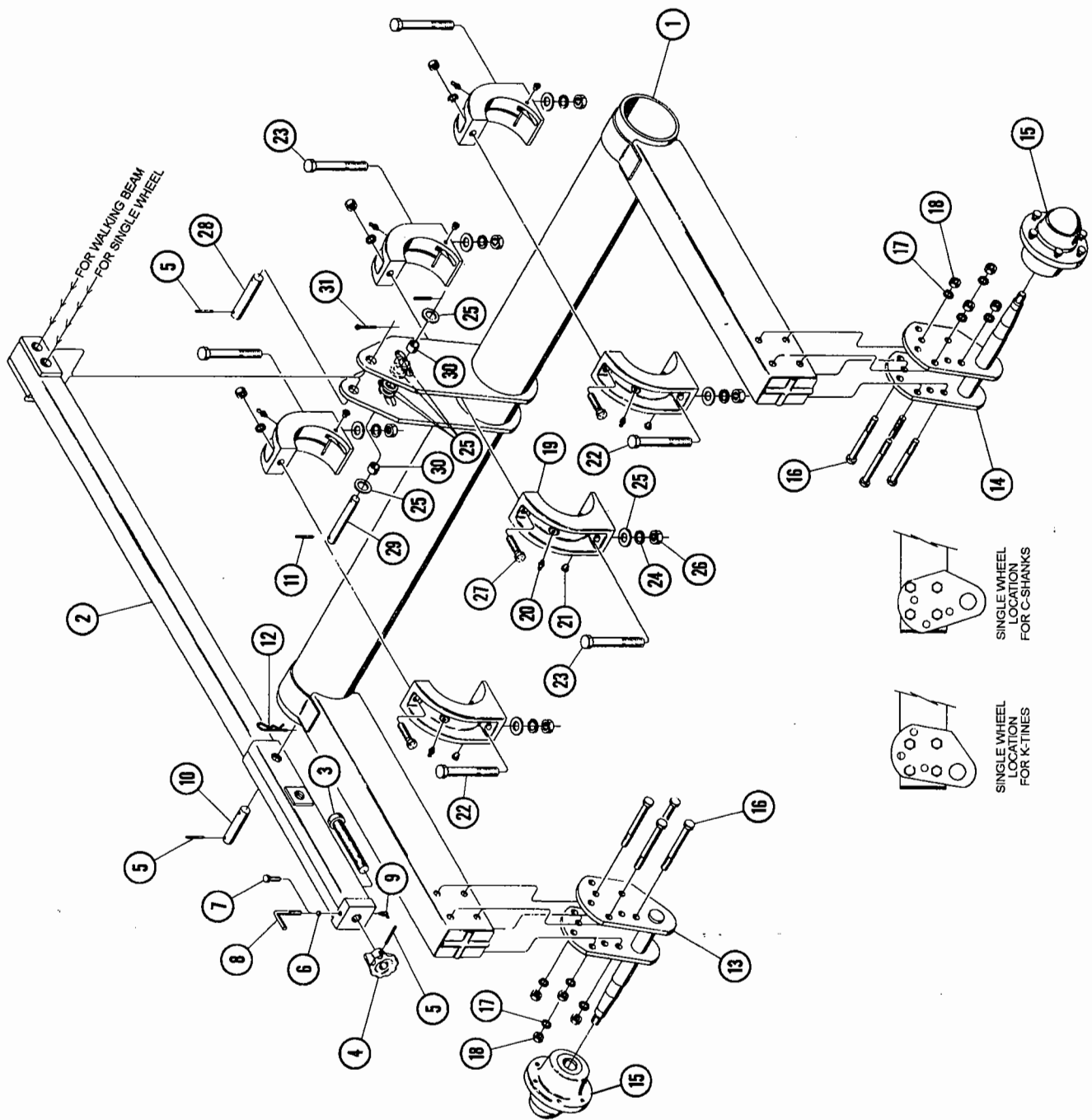

M4200-124  
Revised 10/94



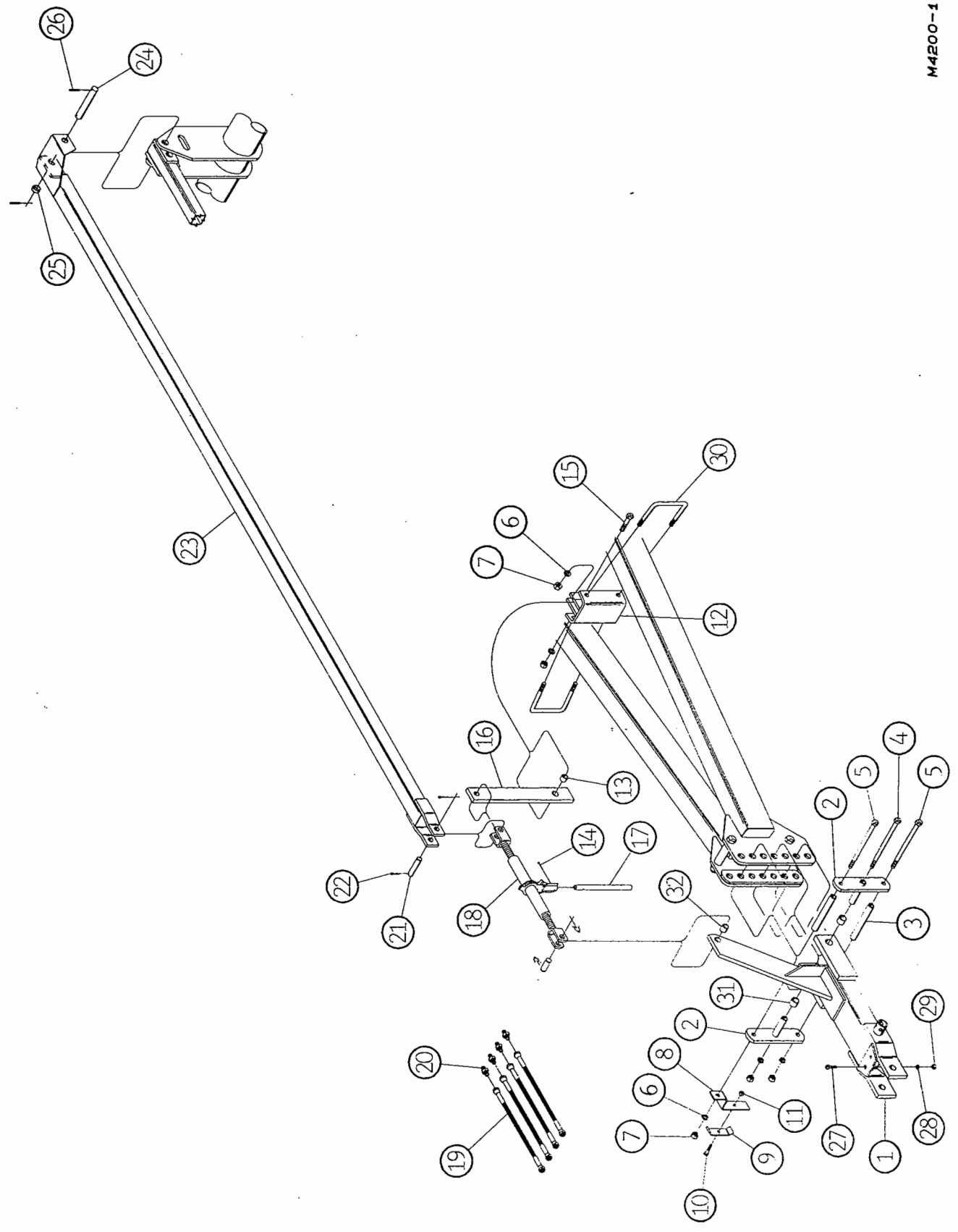



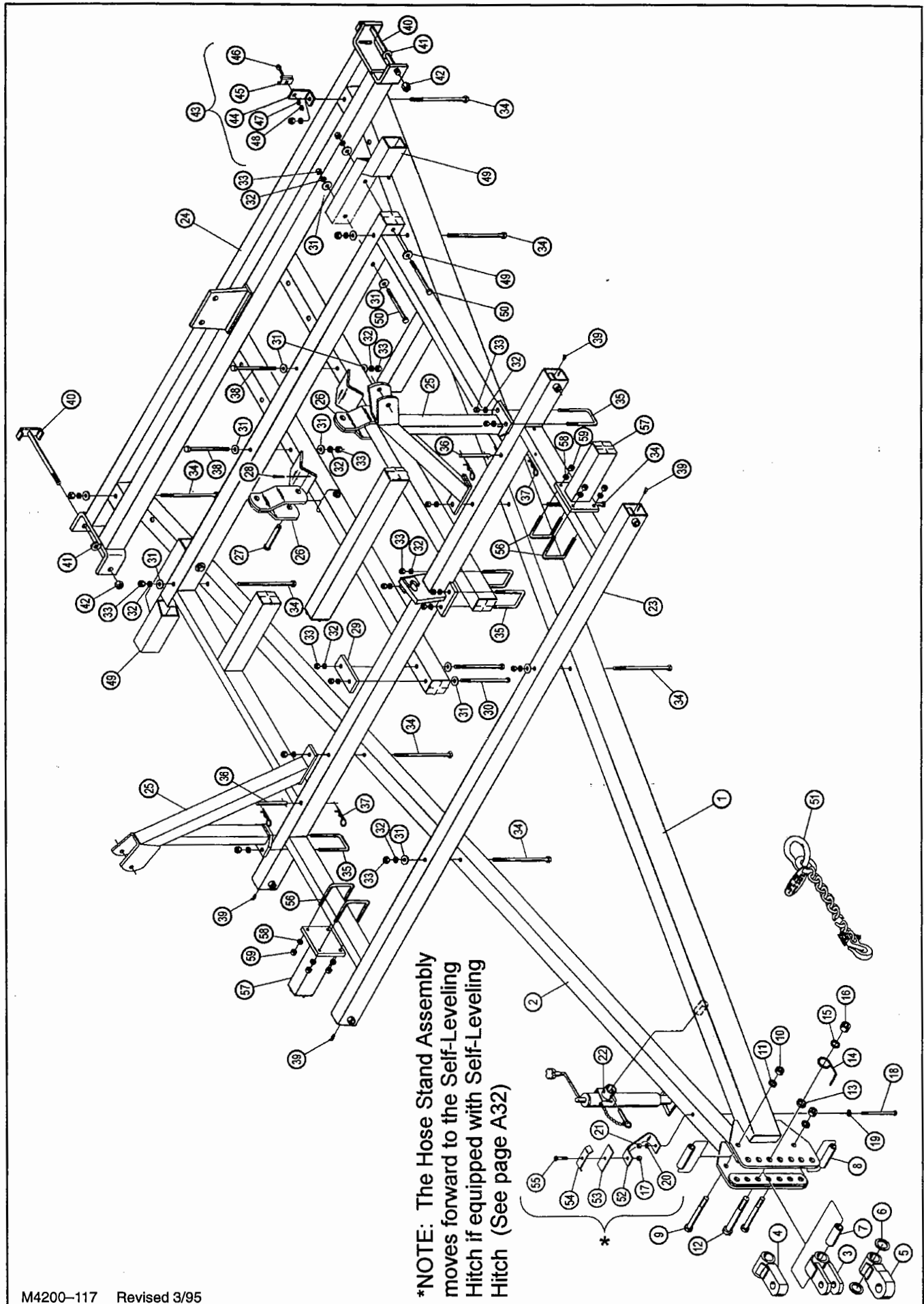

# MAIN FRAME ASSEMBLY

FOR MODELS – 4226, 4231, 4237, 4241

3/95

Item	Part Number	Part Description	Qty
1	★ 4226-8-0	Left Tongue Weldment	1
	○ 4236-5-0	Left Tongue Weldment	1
2	★ 4226-9-0	Right Tongue Weldment	1
	○ 4236-6-0	Right Tongue Weldment	1
3	▲ 770-85-0	Clevis Weldment	1
4	■ 770-86-0	Crawler Clevis Weldment	1
5	■ 1330-54-0	Crawler Clevis Weldment	1
6	64-154	Machinery Bushing (For 1330-54-0)	2
7	1520-0-15	Hitch Tube	1
8	2330-0-5	Spacer Tube	2
9	62-254	1NC x 7-1/2" Cap Screw	2
10	63-117	1NC Hex Nut	3
11	64-118	1" STD. Lock Washer	3
12	62-277	1-1/4NC x 8" Cap Screw	1
13	1901-0-21	Bushing	1
14	76-119	Clevis Spring	1
15	64-126	1-1/4" STD. Flat Washer	1
16	63-126	1-1/4NC Self Locking Nut	1
17	63-108	1/2NC Nylon-Top Lock Nut	1
18	62-161	1/2NC x 7" Cap Screw	1
19	64-108	1/2" STD. Flat Washer	1
20	64-107	1/2" STD. Lock Washer	1
21	63-106	1/2NC Hex Nut	1
22	73-100	Jack Assembly	1
23	4226-5-0B	Front Frame Weldment	1
24	4226-1-0	Rear Frame Weldment	1
25	▼ 4226-28-0	Wing Lock Weldment	2
	● 4231-28-0	Wing Lock Weldment	2
	○ 4241-28-0	Wing Lock Weldment	2
26	4226-29-0	Cylinder Lug Weldment	2
27	60-225	1" DIA. x 5" Clevis Pin	2
28	60-704	3/16" DIA. x 2" Cotter Pin	2
29	3127-206-1A	Plate	1
30	62-224	3/4NC x 10" Machine Bolt	2
31	64-113	3/4" STD. Flat Washer	19
32	64-112	3/4" STD. Lock Washer	24
33	63-112	3/4NC Hex Nut	24
34	62-229	3/4NC x 12" Machine Bolt	8
35	61-207	3/4" Dia. U-Bolt	4
36	1505-0-5	Wing Lock Pin	2
37	60-716	#3 Hair Pin Cotter	4
38	62-221	3/4NC x 9" Machine Bolt	2
39	65-100	1/8NPT x 45 Zerk	4
40	4218-42-0	Rear Hinge Bolt Weldment	2
41	64-141	Special Washer	2

Item	Part Number	Part Description	Qty
42	63-119	1NC Self Locking Nut	2
43	4515-59-0	Lamp Bracket Assembly	1
44	4515-59-1	Lamp Bracket	1
45	74-144	Socket Lamp Bracket	1
46	62-131	7/16NC x 1" Carriage Bolt	1
47	64-105	7/16" STD. Lock Washer	1
48	63-104	7/16NC Hex Nut	1
49	4226-40-0A	Offset Shank Box	2
50	62-216	3/4NC x 7-1/2" Cap Screw	4
51	72-351	10,000# Safety Chain	1
52	4901-0-12	Hose Stand	1
53	2145-170-5	Hose Plate	1
54	2426-170-5	Hose Clamp	1
55	62-142	1/2NC x 2" Cap Screw	1
56	61-195	5/8" DIA. U-Bolt (2 x 4 Box)	4
57	4236-26-0	12" Extension Weldment	2
58	64-109	5/8" STD. Lock Washer	8
59	63-109	5/8NC Hex Nut	8
▼ For Model 4226			
● For Model 4231			
★ For Models 4226 and 4231			
○ For Models 4237 and 4241			
▲ Standard			

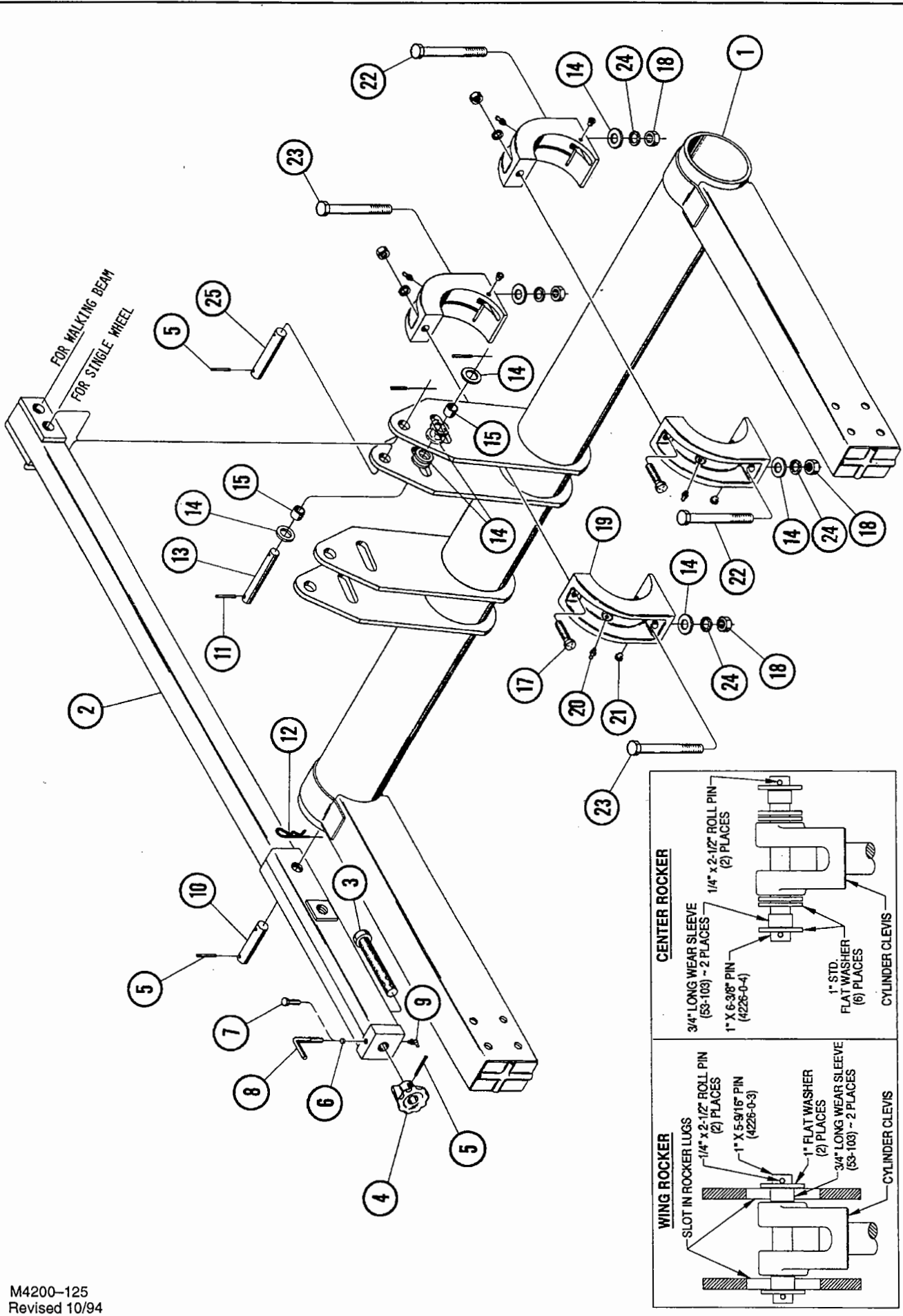

FOR WALKING BEAM  
FOR SINGLE WHEEL

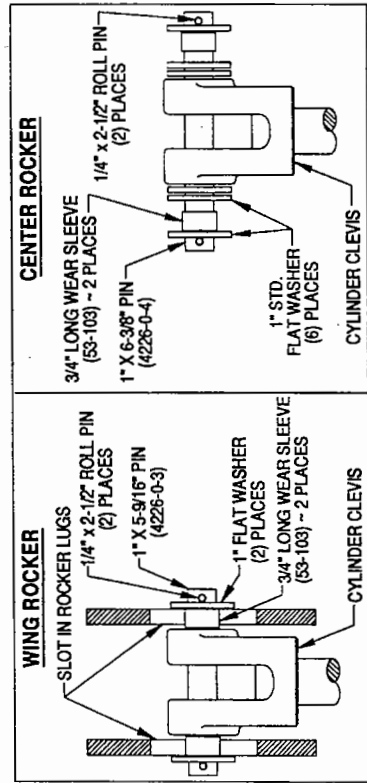

M4200-125  
Revised 10/94



M4200-R

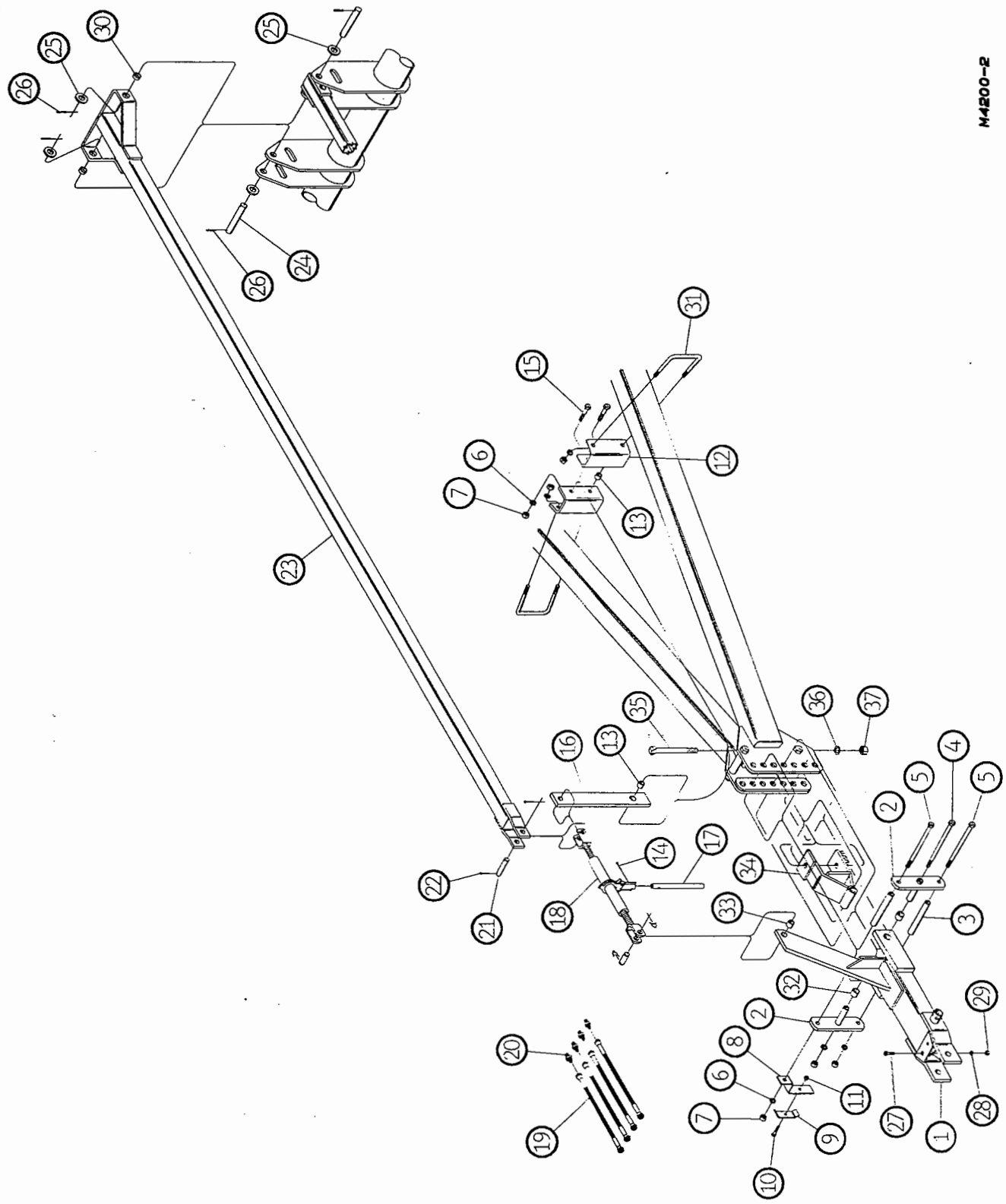

## SELF-LEVELING TONGUE -- ACCESSORY

FOR MODELS -- 4226, 4231, 4237, 4241

7/94

Item	Part Number	Part Description	Qty.
	4226-50-0	Accessory -- Self-Leveling Hitch Group	
1	4226-41-0	Leveling Tongue Weldment	1
2	4226-44-0	Pivot Plate Weldment	2
3	4226-0-7	1-1/4" x 8-1/16" Sleeve	2
4	62-228	3/4NC x 11" GD. 5 Machine Bolt	1
5	62-226	3/4NC x 10-1/2" Machine Bolt	2
6	64-112	3/4" STD. Lock Washer	9
7	63-112	3/4NC Hex Nut	9
8	4223-53-1	Hose Bracket	1
9	2426-170-5	Hose Clamp	1
10	62-142	1/2NC x 2" Cap Screw	1
11	63-108	1/2NC Self Locking Nut	1
12	4226-49-2	Link Mounting	2
13	612-0-2	Spacer	2
14	60-708	1/4" x 1-3/4" Cotter Pin	1
15	62-197	3/4NC x 3" GD. 5 Cap Screw	2
16	4226-49-1	Support Link	1
17	4000-50-2	6-1/2" Handle	1
18	4000-48-0	Ratchet Jack	1
19	24-360	1/2" DIA. x 20" Hose Assembly (3/4" Swivel Both Ends)	4
20	25-304	3/4" JIC Male Coupler	4
21	4226-0-8	1"DIA. x 4" Pin	1
22	60-702	3/16" x 1-1/2" Cotter Pin	2
23	4226-46-0	Leveling Link Weldment	1
24	4226-0-9	1-1/4" DIA. x 7-1/16" Pin	2
25	64-127	1-1/4" SAE Flat Washer	4
26	60-606	1/4" x 2" Roll Pin	4
27	62-136	1/2NC x 1-1/2" Cap Screw	1
28	64-107	1/2" STD. Lock Washer	1
29	63-106	1/2NC Hex Nut	1
30	53-109	Wear Sleeve (Pressed in)	2
31	61-120	3/4" DIA. U-Bolt	2
32	53-101	Wear Sleeve	2
33	53-102	Wear Sleeve	1
34	4226-58-0	Hitch Support Weldment	1
35	62-601	1NC x 10" GD. 5 Machine Bolt	1
36	64-118	1" STD. Lock Washer	1
37	63-117	1NC Hex Nut	1

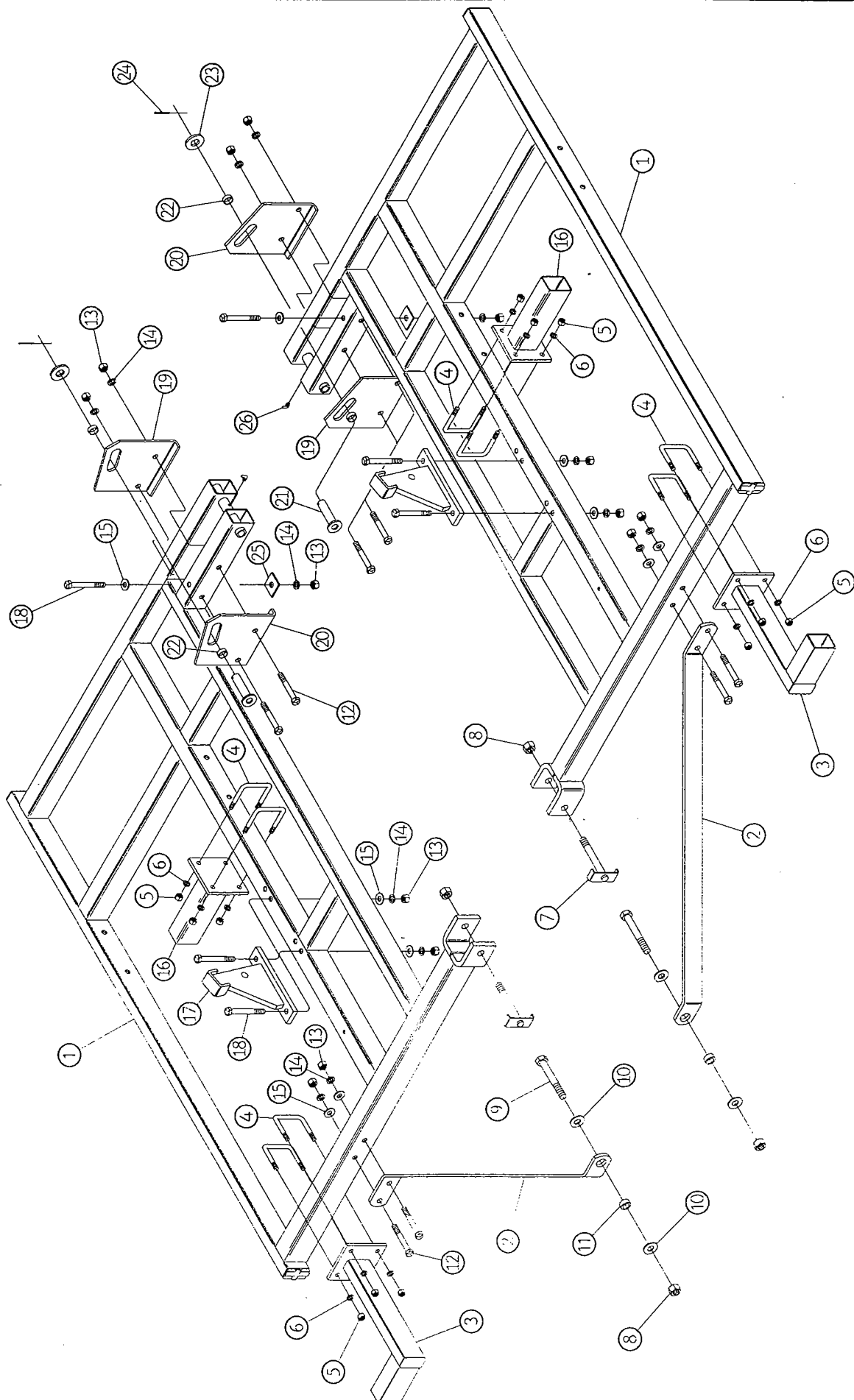



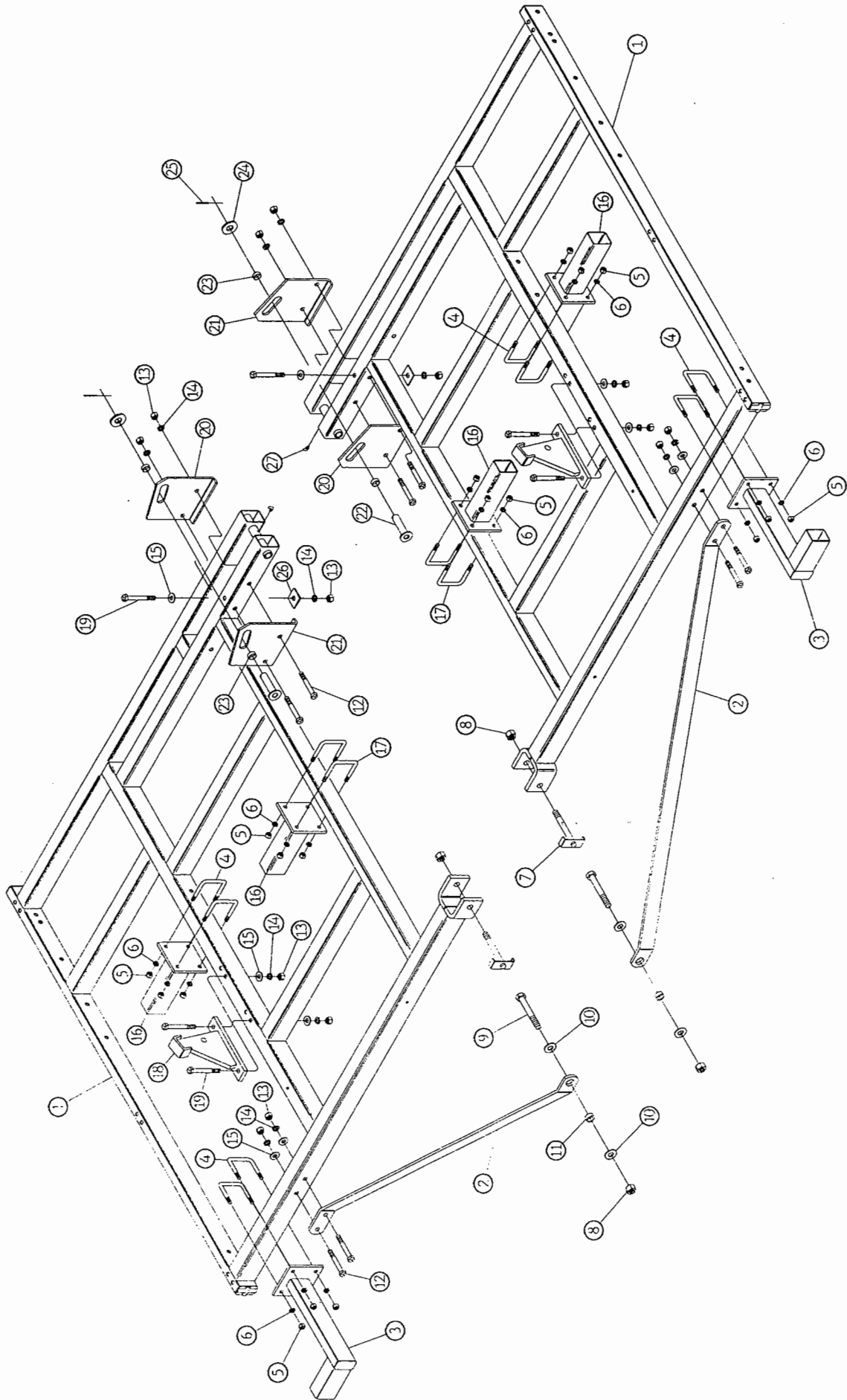

## WING FRAME ASSEMBLY

FOR MODELS – 4223

3/94

Item	Part Number	Part Description	Qty.
1	4223-18-0A	Wing Frame Weldment	2
2	4223-0-2	Wing Strap	2
3	4218-24-0	Front Shank Extension Weldment	2
4	61-126	5/8" DIA. U-Bolt (For 3 x 4 Box)	8
5	63-109	5/8NC Hex Nut	24
6	64-109	5/8" STD. Lock Washer	24
7	4122-43-0	Hinge Bolt Weldmen	2
8	63-119	1NC Self Locking Nut	4
9	62-252	1NC x 7" Cap Screw	2
10	64-119	1" STD. Flat Washer	4
11	4122-0-6	Spacer	2
12	62-205	3/4NC x 5" GRD. 5 Cap Screw	8
13	63-112	3/4NC Hex Nut	14
14	64-112	3/4" STD. Lock Washer	14
15	64-113	3/4" STD. Flat Washer	10
16	4236-26-0	12" Shank Extension Weldment	4
17	61-195	5/8" DIA. U-Bolt (For 2 x 4 Box)	4
18	4218-17-0	Cylinder Lug Weldment	2
19	62-210	3/4NC x 6" GRD. 5 Cap Screw	6
20	4218-30-0	Right Cylinder Lug	2
21	4218-31-0	Left Cylinder Lug	2
22	3131-77-0	Cylinder Clevis Pin	2
23	53-109	Wear Sleeve	4
24	64-126	1-1/4" Flat Washer	2
25	60-608	1/4" DIA. x 2-1/2" Roll Pin	2
26	3755-12-2	Square Washer	2
27	65-102	1/8NPT x 90° Zerk	2

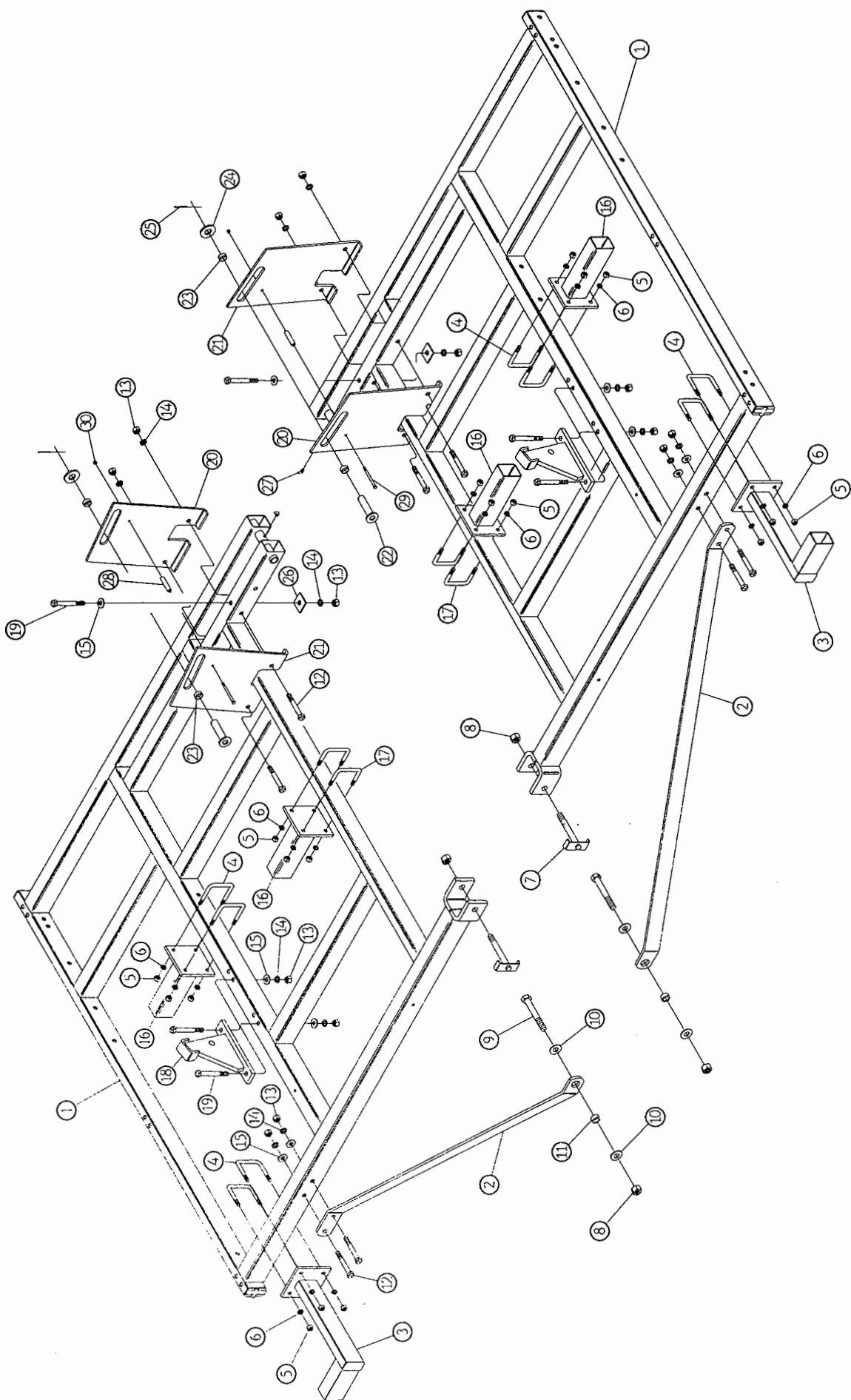



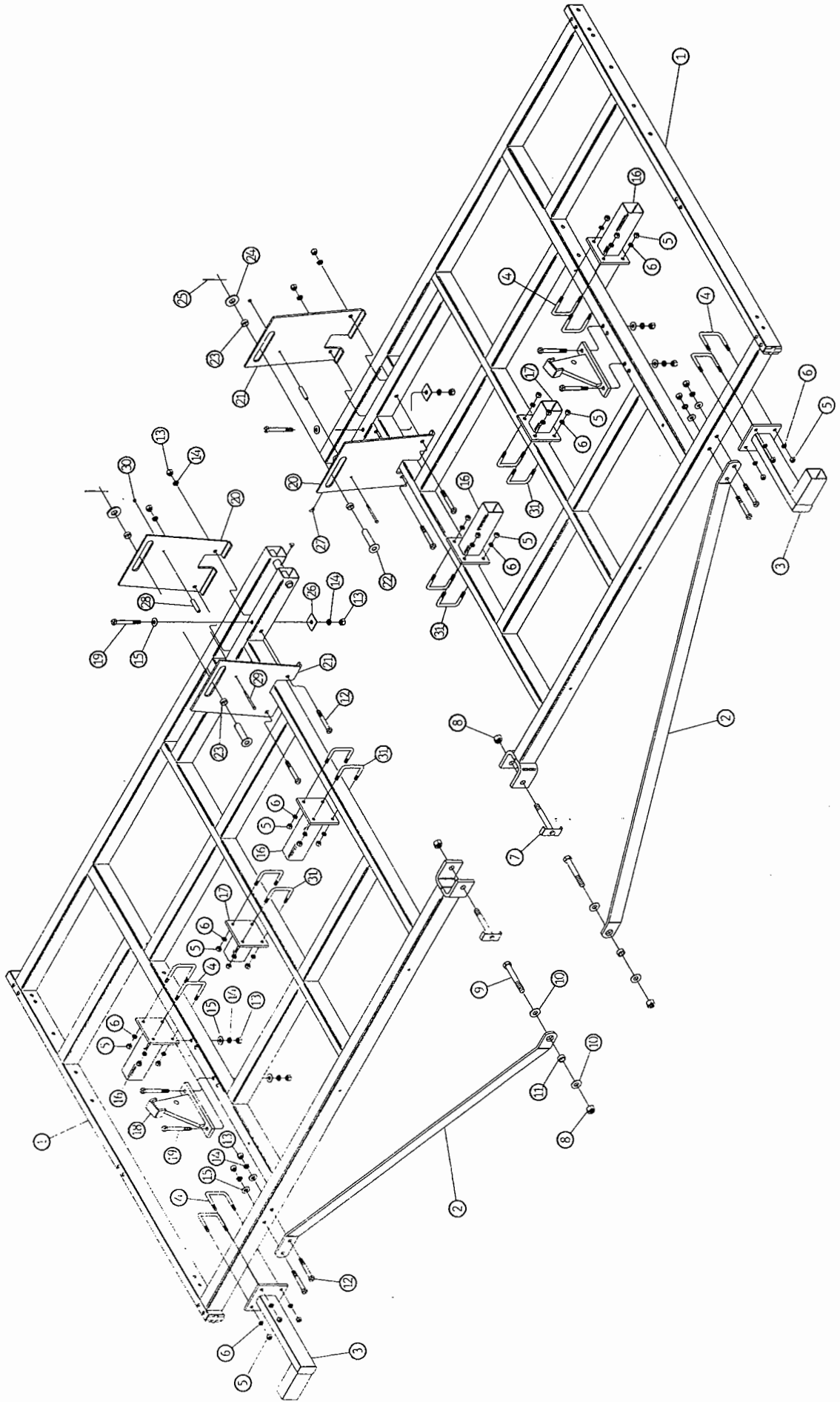



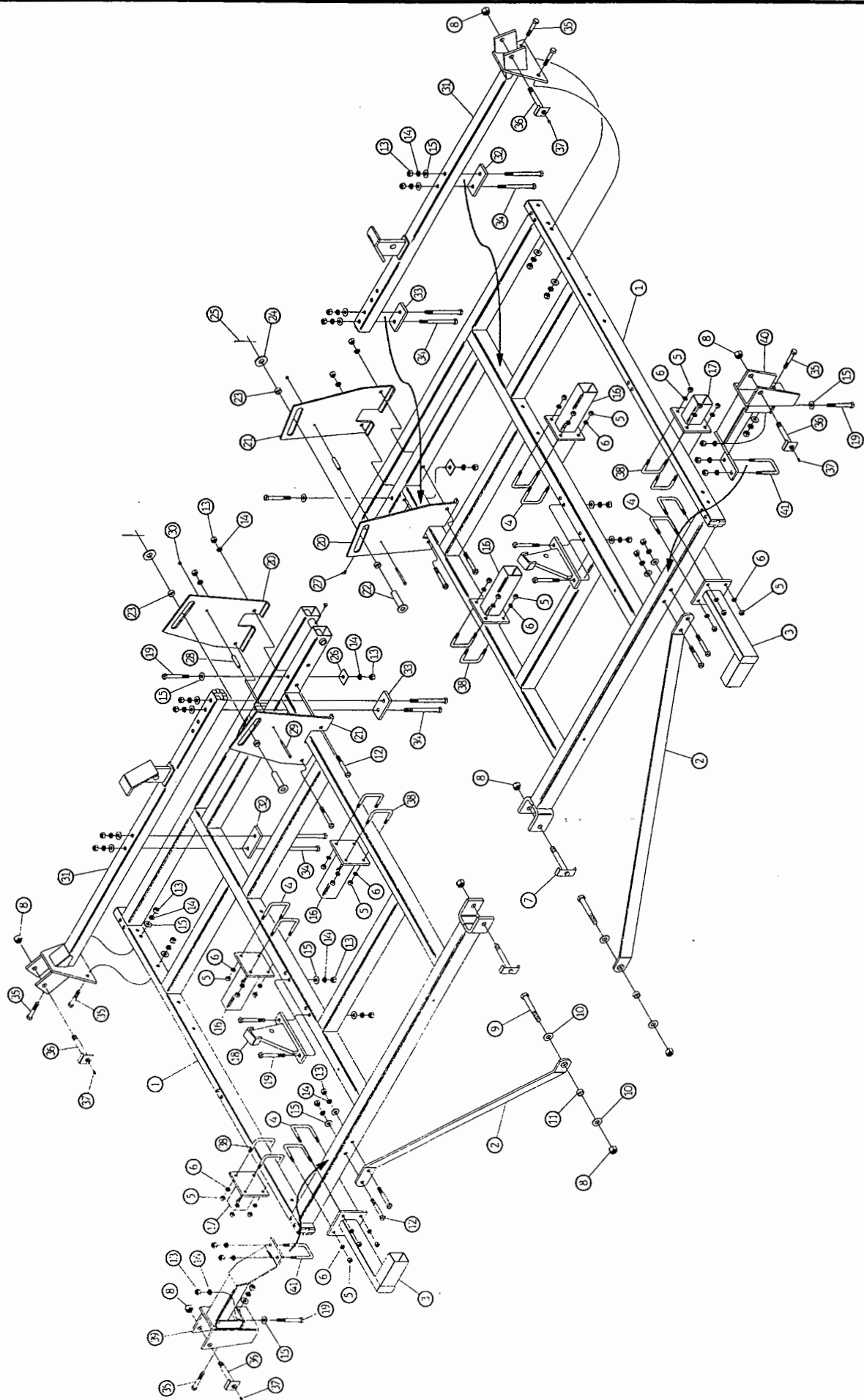

# WING FRAME ASSEMBLY

FOR MODELS – 4237

3/94

<i>Item</i>	<i>Part Number</i>	<i>Part Description</i>	<i>Qty.</i>
1	4223-18-0A	Wing Frame Weldment	2
2	4223-0-2	Wing Strap	2
3	4218-24-0	Front Shank Extension Weldment	2
4	61-126	5/8" DIA. U-Bolt (For 3 x 4 Box)	8
5	63-109	5/8NC Hex Nut	32
6	64-109	5/8" STD. Lock Washer	32
7	4122-43-0	Hinge Bolt Weldment	2
8	63-119	1NC Self Locking Nut	8
9	62-252	1NC x 7" Cap Screw	2
10	64-119	1" STD. Flat Washer	4
11	4122-0-6	Spacer	2
12	62-205	3/4NC x 5" GD. 5 Cap Screw	8
13	63-112	3/4NC Hex Nut	34
14	64-112	3/4" STD. Lock Washer	34
15	64-113	3/4" STD. Flat Washer	24
16	4236-26-0	12" Shank Extension Weldment	4
17	5660-16-0	6" Shank Extension Weldment	2
18	4218-17-0	Cylinder Lug Weldment	2
19	62-210	3/4NC x 6" GRD. 5 Cap Screw	8
20	4237-36-0	Right Cylinder Lug	2
21	4237-37-0	Left Cylinder Lug	2
22	3131-77-0	Cylinder Clevis Pin	2
23	53-109	Wear Sleeve	4
24	64-126	1-1/4" STD. Flat Washer	2
25	60-608	1/4" DIA. x 2-1/2" Roll Pin	2
26	3755-12-2	Square Washer	2
27	65-102	1/8NPT x 90° Zerk	2
28	4241-0-2	Spacer Tube	2
29	62-447	3/8NC x 4-1/2" Cap Screw	2
30	63-103	3/8NC Self Locking Nut	2
31	4241-13-0A	Rear Hinge Weldment	2
32	3172-206-1A	Bolt Plate (For 3" Box)	2
33	4241-0-1	Bolt Plate (For 2" Box)	2
34	62-221	3/4NC x 9" Machine Bolt	8
35	62-200	3/4NC x 4" Cap Screw	6
36	4241-45-0	Outer Hinge Pin Weldment	4
37	65-110	1/8NPT Thread Cutting Zerk	4
38	61-195	5/8" DIA. U-Bolt (For 2 x 4 Box)	8
39	4241-30-0	Right Hinge Weldment	1
40	4241-31-0	Left Hinge Weldment	1
41	61-207	3/4" DIA. U-Bolt	2

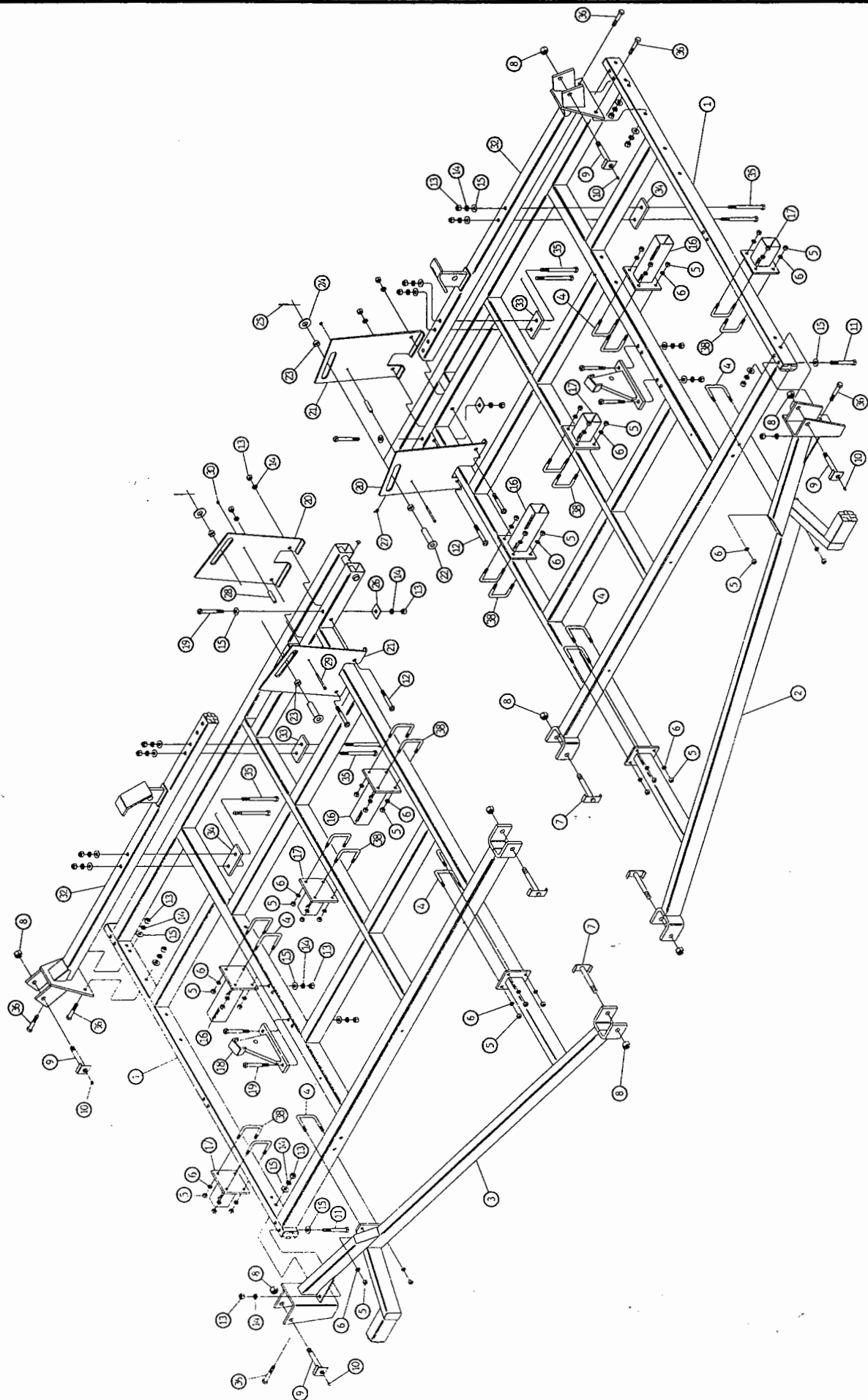

# WING FRAME ASSEMBLY

FOR MODELS - 4241

10/94

Item	Part Number	Part Description	Qty.
1	4231-18-0A	Wing Frame Weldment	2
2	4241-24-0	Left Brace Weldment	1
3	4241-25-0	Right Brace Weldment	1
4	61-126	5/8" DIA. U-Bolt (For 3 x 4 Box)	10
5	63-109	5/8NC Hex Nut	44
6	64-109	5/8" STD. Lock Washer	44
7	4122-43-0	Hinge Bolt Weldment	4
8	63-119	1NC Self Locking Nut	8
9	4241-45-0	Outer Hinge Pin Weldment	4
10	65-110	1/8NPT Thread Cutting Zerk	4
11	62-209	3/4NC x 6" Cap Screw	2
12	62-205	3/4NC x 5" GD. 5 Cap Screw	4
13	63-112	3/4NC Hex Nut	34
14	64-112	3/4" STD. Lock Washer	34
15	64-113	3/4" STD. Flat Washer	28
16	4236-26-0	12" Shank Extension Weldment	4
17	5660-16-0	6" Shank Extension Weldment	4
18	4218-17-0	Cylinder Lug Weldment	2
19	62-210	3/4NC x 6" GD. 5 Cap Screw	6
20	4241-36-0	Right Cylinder Lug	2
21	4241-37-0	Left Cylinder Lug	2
22	3131-77-0	Cylinder Clevis Pin	2
23	53-109	Wear Sleeve	4
24	64-126	1-1/4" STD. Flat Washer	2
25	60-608	1/4" DIA. x 2-1/2" Roll Pin	2
26	3755-12-2	Square Washer	2
27	65-102	1/8NPT x 90° Zerk	2
28	4241-0-2	Spacer Tube	2
29	62-447	3/8NC x 4-1/2" Cap Screw	2
30	63-103	3/8NC Self Locking Nut	2
31	4122-60-0	Short Shank Extension Weldment	2
32	4241-13-0A	Rear Hinge Weldment	2
33	4241-0-1	Bolt Plate (For 2" Box)	2
34	3127-206-1A	Bolt Plate (For 3" Box)	2
35	62-221	3/4NC x 9" Cap Screw	8
36	62-200	3/4NC x 4" Cap Screw	6
37	62-198	3/4NC x 3-1/2" Cap Screw	4
38	61-195	5/8" DIA. U-Bolt (For 2 x 4 Box)	12

PIN SHOULD BE ASSEMBLED IN THE BACK HOLE TO PREVENT ROCKER FROM ROTATING WHICH WOULD ALLOW TIRE INTERFERENCE WITH THE SWEEP POINT.

PIN THE FRONT HOLE ONLY WHEN CHANGING SWEEPS.

**SPECIAL NOTE:**  
ROCKER LUG DAMAGE COULD RESULT IF THE CYLINDERS ARE RETRACTED IN THE FRONT HOLE.

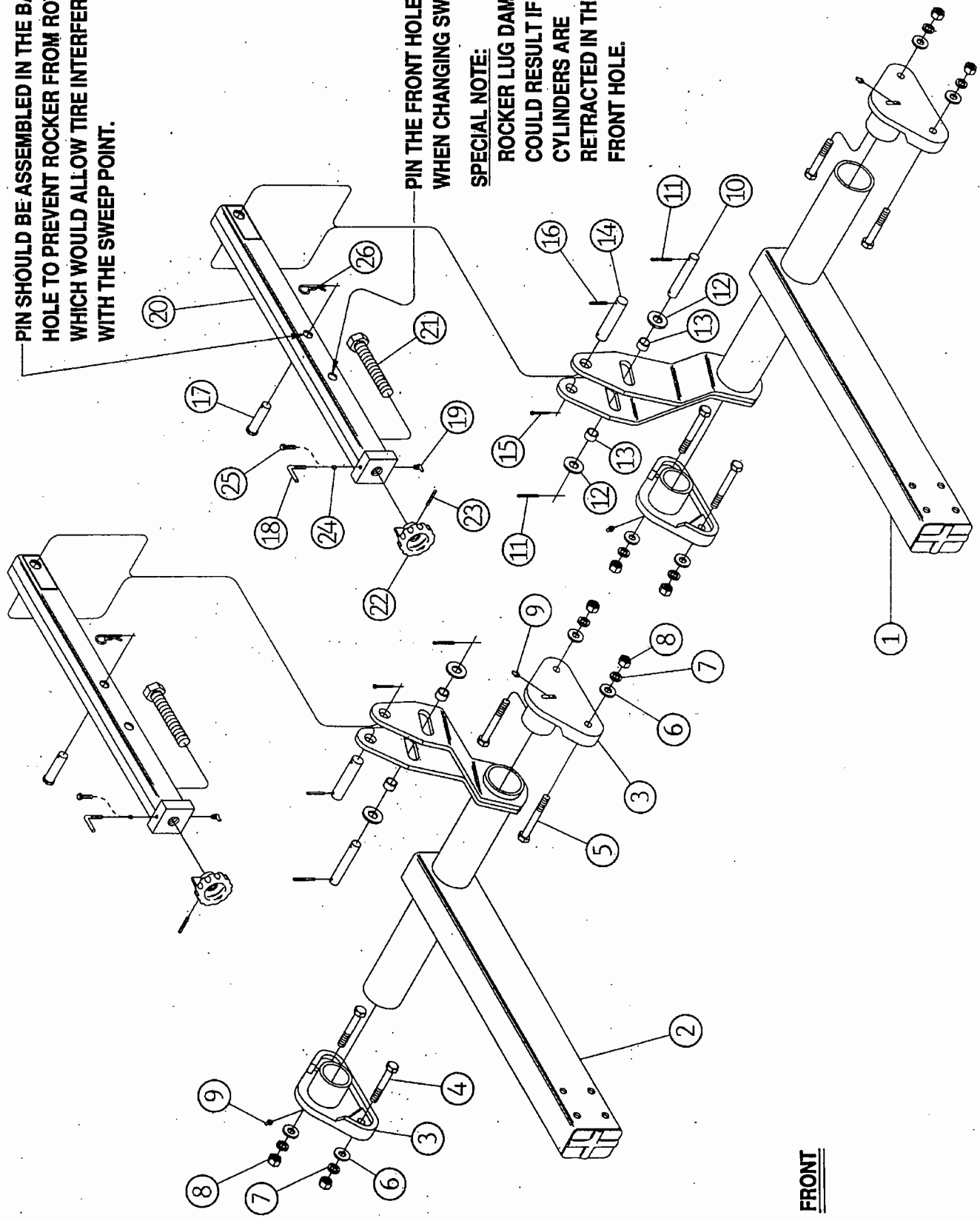

**FRONT**



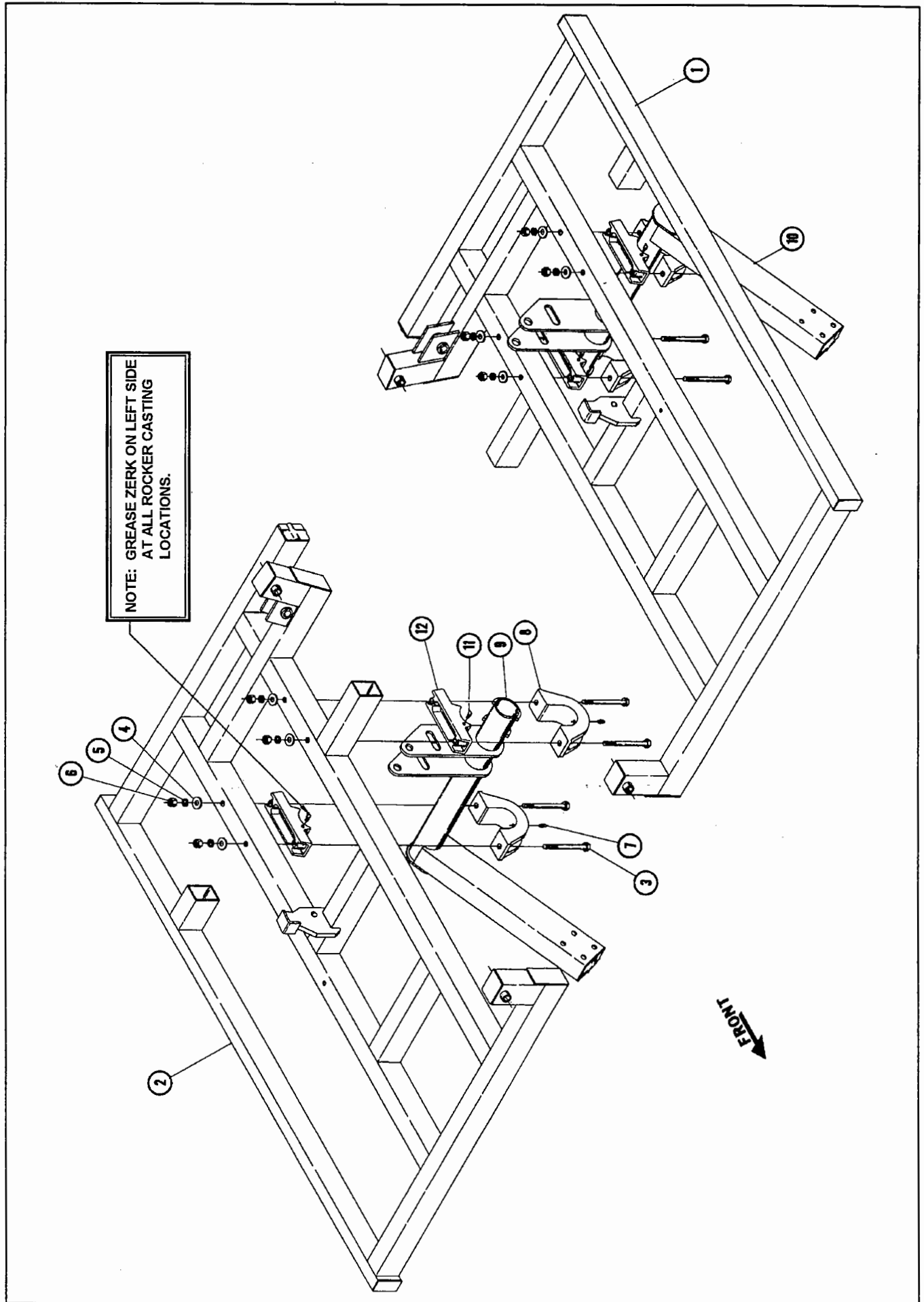





# FOLD OVER EXTENSIONS

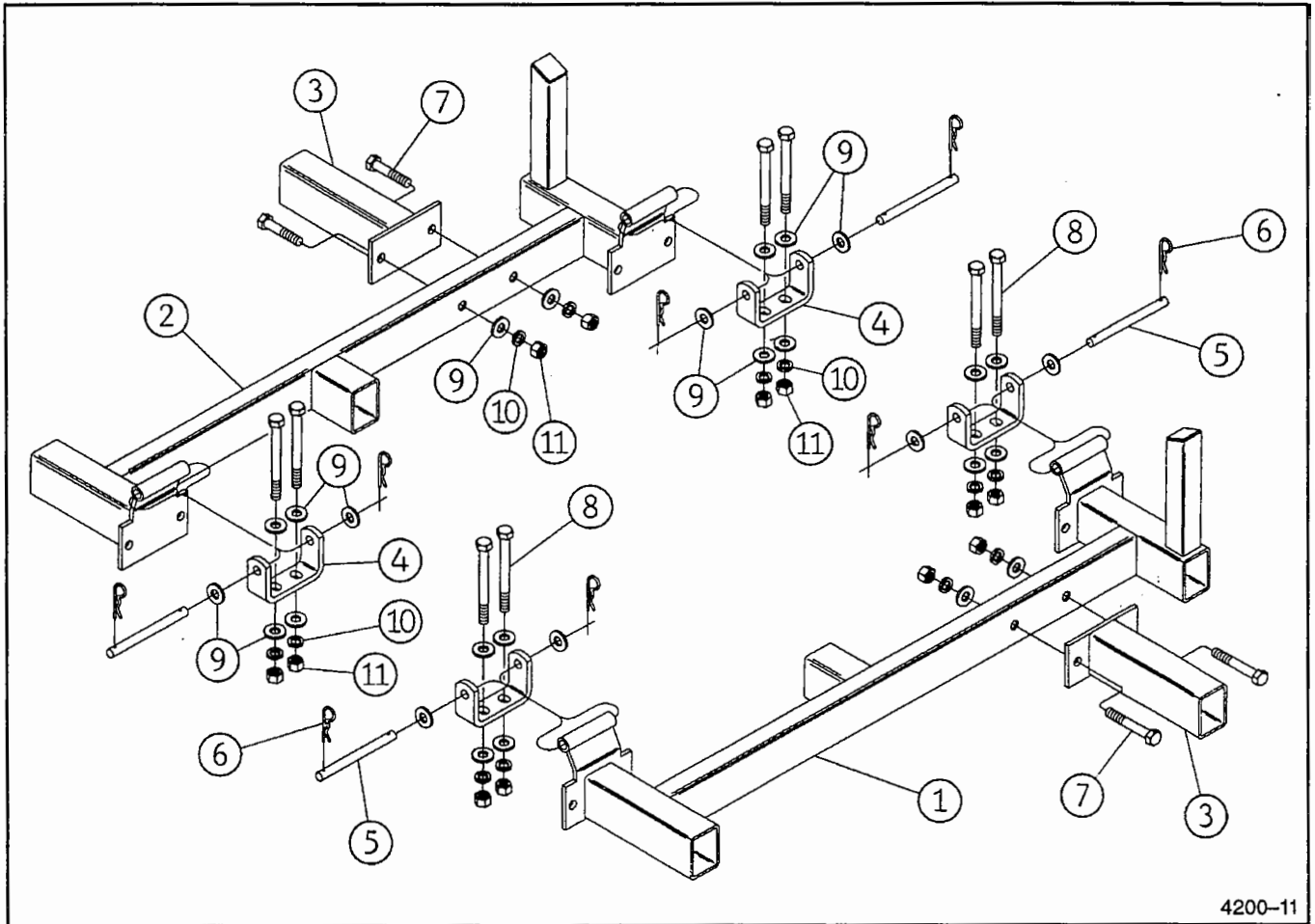

4200-11

FOR MODELS - 4231

12/89

Item	Part Number	Part Description	Qty.
1	4231-80-0	Left Folding Extension Weldment	1
2	4231-81-0	Right Folding Extension Weldment	1
3	4200-42-0	2-Shank Extension Weldment	2
4	4122-70-2	Hinge Stirrup	4
5	4122-70-1	Hinge Pin	4
6	60-716	#3 Hair Pin Cotter	8
7	62-198	3/4NC x 3-1/2" Cap Screw	4
8	62-209	3/4NC x 6" Cap Screw	8
9	64-113	3/4" STD. Flat Washer	28
10	64-112	3/4" STD. Lock Washer	12
11	63-112	3/4NC Hex Nut	12

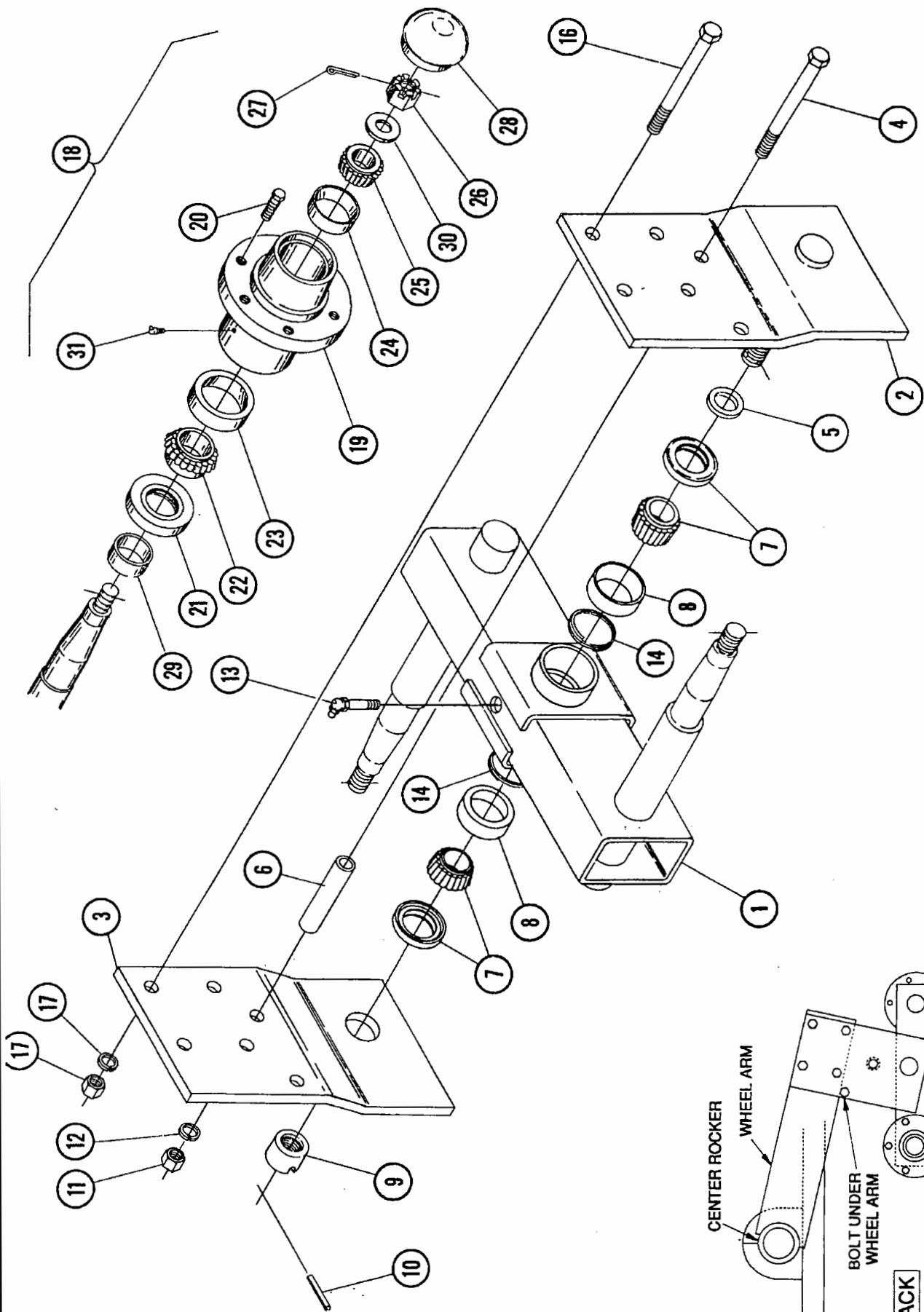

RIGHT CENTER WALKING BEAM (SHOWN)



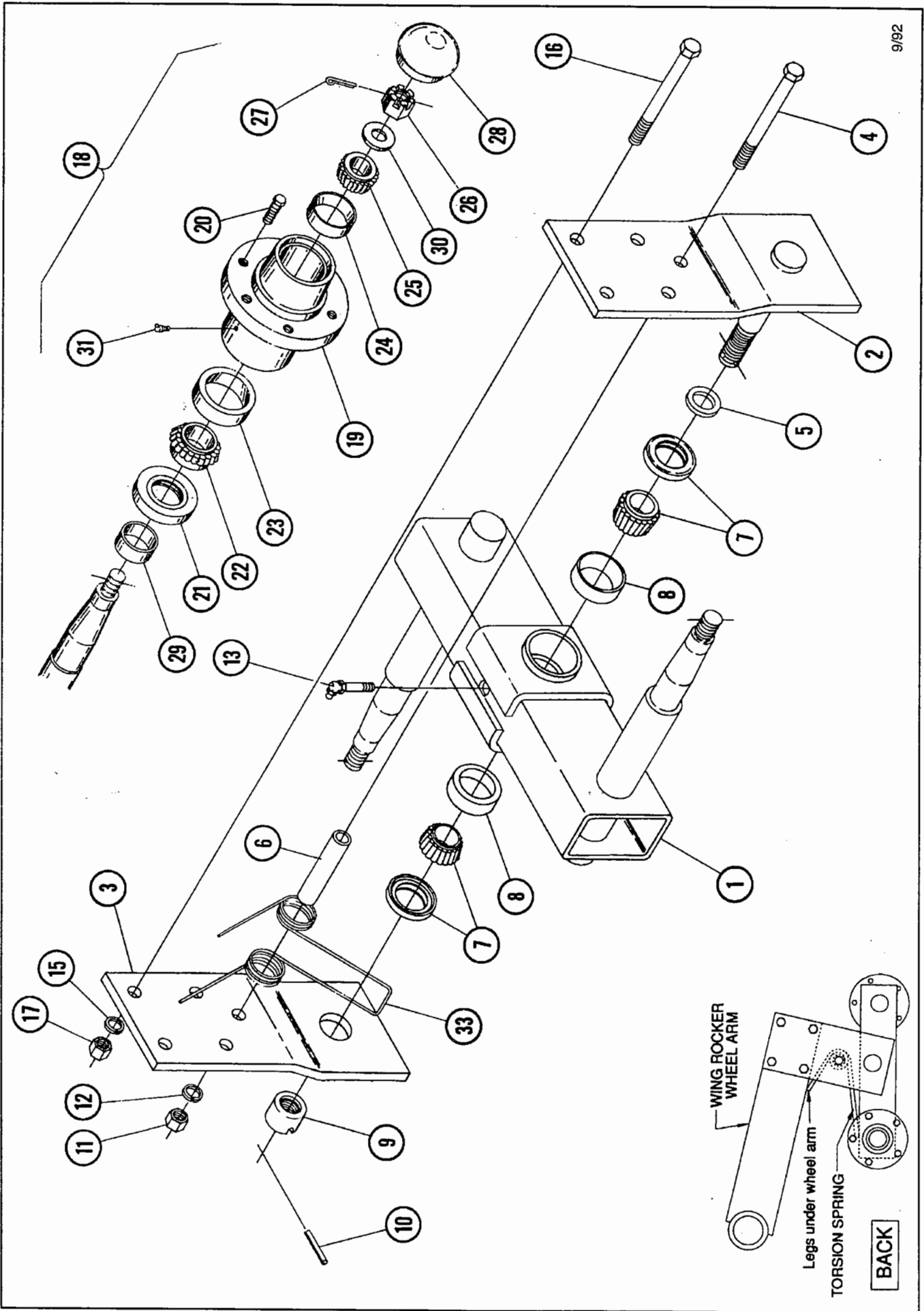



# SINGLE AXLE & HUB ASSEMBLY

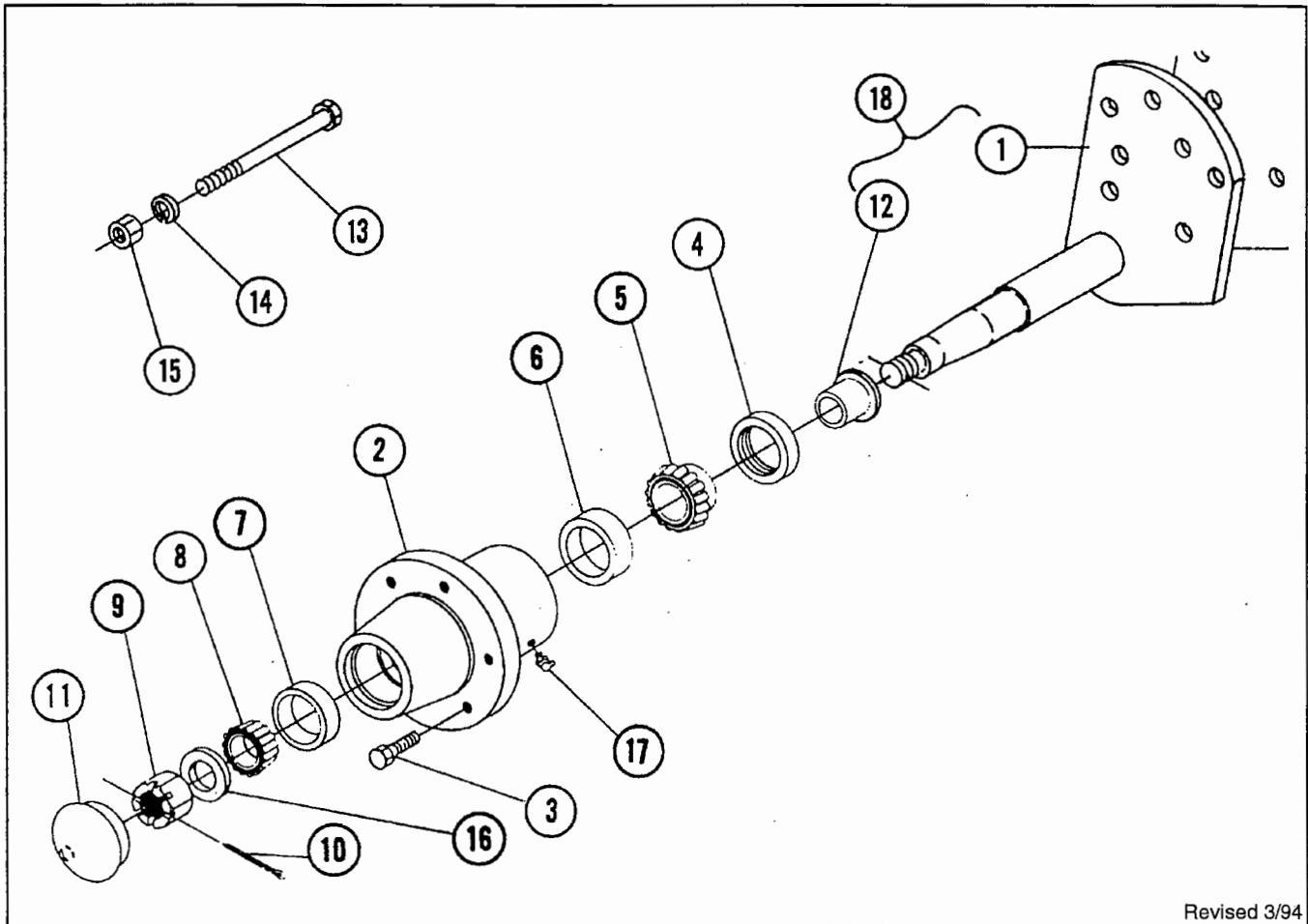

Revised 3/94

**FOR MODELS - 4218, 4223, 4226 WINGS**

3/95

Item	Part Number	Part Description	Qty.
	4223-43-0	Right Single Axle and Hub Assembly	1
	4223-44-0	Left Single Axle and Hub Assembly	1
1	4223-41-0	Right Single Axle Weldment	1
	4223-42-0	Left Single Axle Weldment	1
2	1918-8-1	Hub Casting	1
3	62-295	Wheel Bolt	6
4	42-108	Seal	1
5	41-113	Rear Cone	1
6	41-209	Rear Cup	1
7	41-208	Front Cup	1
8	41-112	Front Cone	1
9	63-204	1NF Slotted Hex Nut	1
10	60-702	3/16" DIA. x 1-1/2" Cotter Key	1
11	52-302	Hub Cap	1
12	53-105	Wear Ring	1
13	☆ 62-209	3/4NC x 6" Cap Screw	4
14	☆ 64-112	3/4" STD. Lock Washer	4
15	☆ 63-112	3/4NC Hex Nut	4
16	64-120	1" SAE Flat Washer	1
17	65-104	1/4NPT x 67-1/2° Zerk	1
18	☆ 4223-45-0	Repair Right Spindle and Sleeve (For repairs only)	
	4223-46-0	Repair Left Spindle and Sleeve (For repairs only)	

☆ Not Part of Single Axle and Hub Assembly

# WING SECTION HUB ASSEMBLY

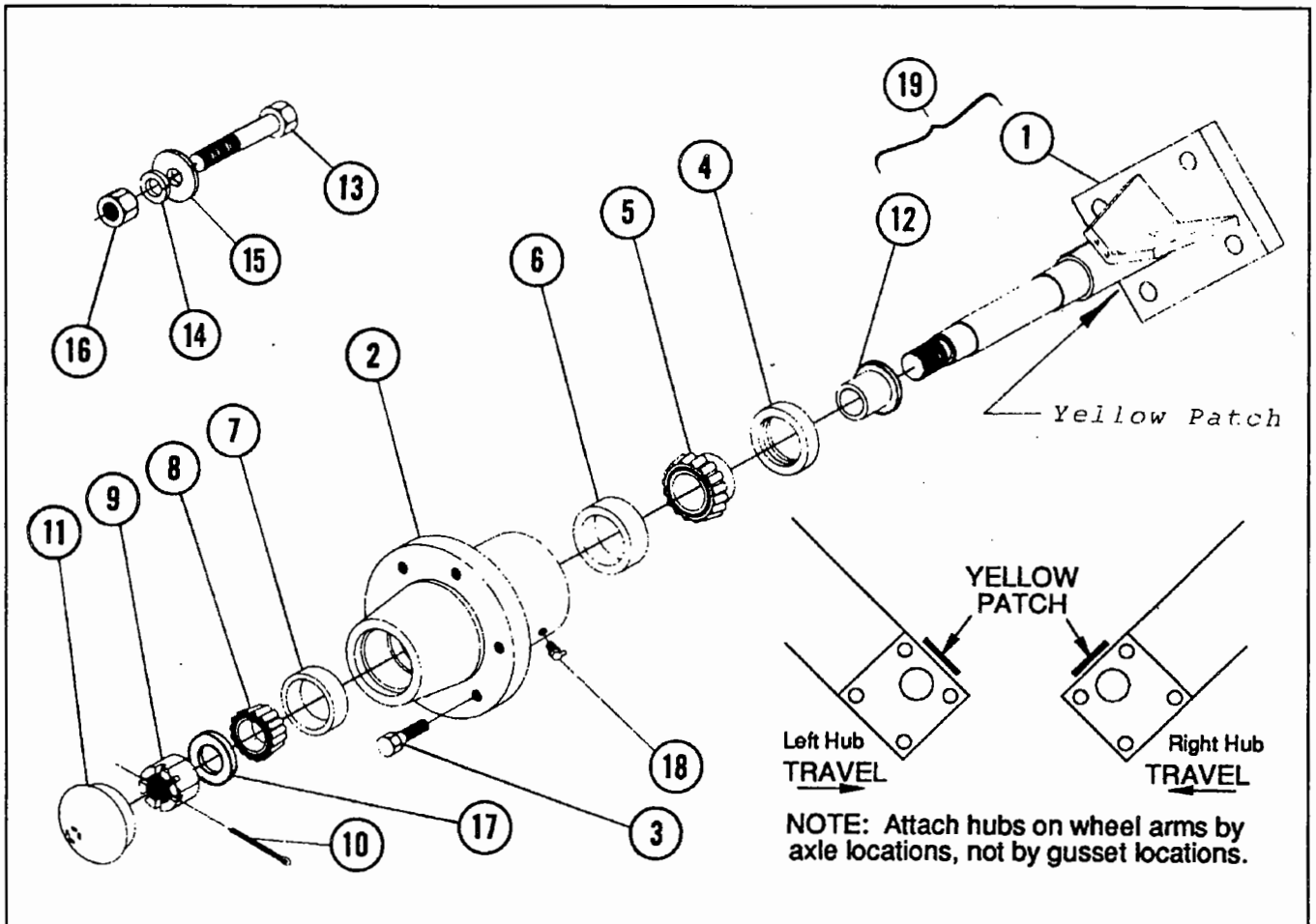

**FOR MODELS - 4241 OUTER WING**

**12/89**

Item	Part Number	Part Description	Qty.
	1918-17-0	Hub and Axle Assembly	1
1	1918-12-0	Stub Axle Weldment	1
2	1918-8-1	Hub Casting	1
3	62-295	Wheel Bolt	6
4	42-108	Seal	1
5	41-113	Rear Cone	1
6	41-209	Rear Cup	1
7	41-208	Front Cup	1
8	41-112	Front Cone	1
9	63-204	1NF Slotted Hex Nut	1
10	60-702	3/16" DIA. x 1-1/2" Cotter Key	1
11	52-302	Hub Cap	1
12	53-105	Wear Ring	1
13	★ 62-209	3/4NC x 6" Cap Screw	4/hub
14	★ 64-112	3/4" STD. Lock Washer	4/hub
15	★ 64-113	3/4" STD. Flat Washer	4/hub
16	★ 63-112	3/4NC Hex Nut	4/hub
17	64-120	1" SAE Flat Washer	1
18	65-104	1/4NPT x 67-1/2° Zerk	1
19	1918-15-0	Repair Spindle & Sleeve Assembly	1

★ Not Part of Hub Assembly

## WHEELS & TIRES

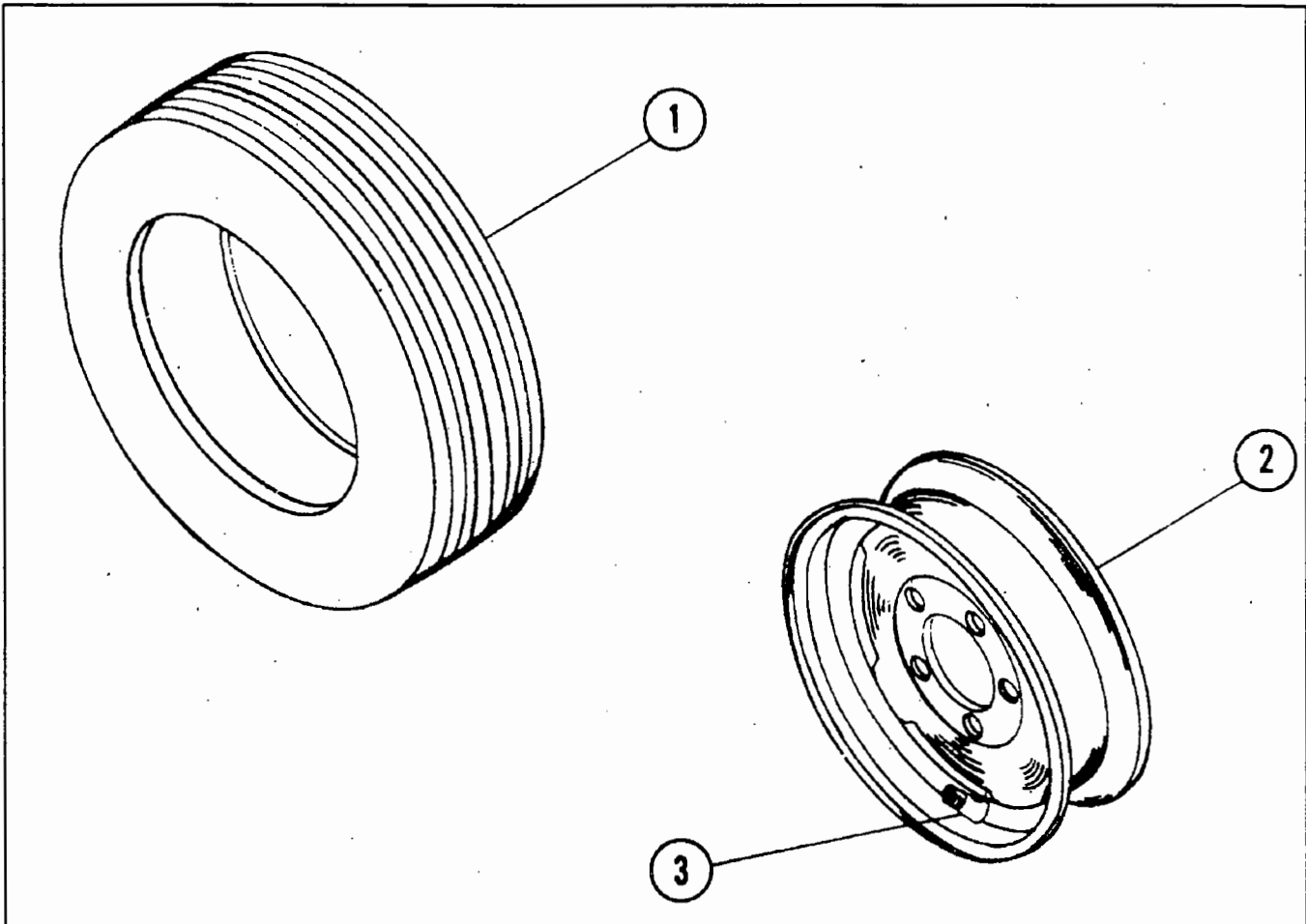

**FOR MODELS - ALL**

**12/89**

Item	Part Number	Part Description	Qty.
	1000-95568-0	Wheel Assembly	Specify
1	51-101	Tire 9.5L x 15, 6-Ply	1
2	52-102	Wheel 15" x 8"	1
3	51-107	Valve Stem #415	1
	1000-11560-0	Wheel Assembly	Specify
1	51-105	Tire 11L x 15, 6-Ply	1
2	52-103	Wheel 15" x 10"	1
3	51-107	Valve Stem #415	1
	1000-95588-0	Wheel Assembly	Specify
1	51-102	Tire 9.5L x 15, 8-Ply	1
2	52-102	Wheel 15" x 8"	1
3	51-107	Valve Stem #415	1

# REAR JACK MOUNTING & TIRE SCRAPERS

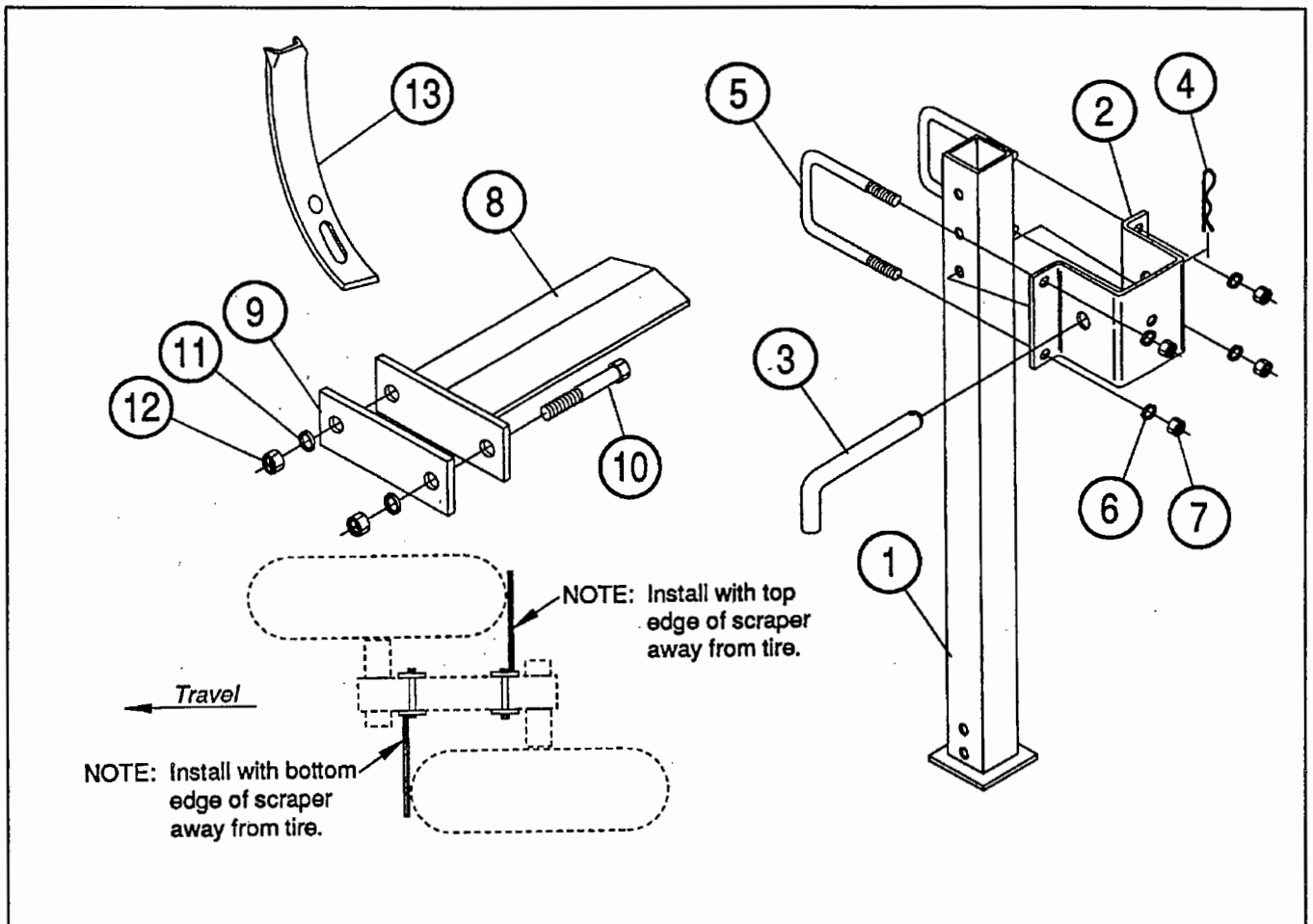

**FOR MODELS - 4241 OUTER WING**

7/90

Item	Part Number	Part Description	Qty.
1	4218-27-0	Stand Weldment	2
2	4218-0-5	Stand Bracket	2
3	4600-0-28	Stand Pin	2
4	60-716	#3 Hair Pin Cotter	2
5	61-160	1/2" DIA. U-Bolt	4
6	64-107	1/2" STD. Lock Washer	8
7	63-106	1/2NC Hex Nut	8
	4133-105-0	Tire Scraper Assembly	1
8	4901-106-0	Tire Scraper	1
9	4901-106-1	Bolt Plate	1
10	62-180	5/8NC x 4-1/2" Cap Screw	2
11	64-109	5/8" STD. Lock Washer	2
12	63-109	5/8NC Hex Nut	2
13	31-148	Wear Plate	1

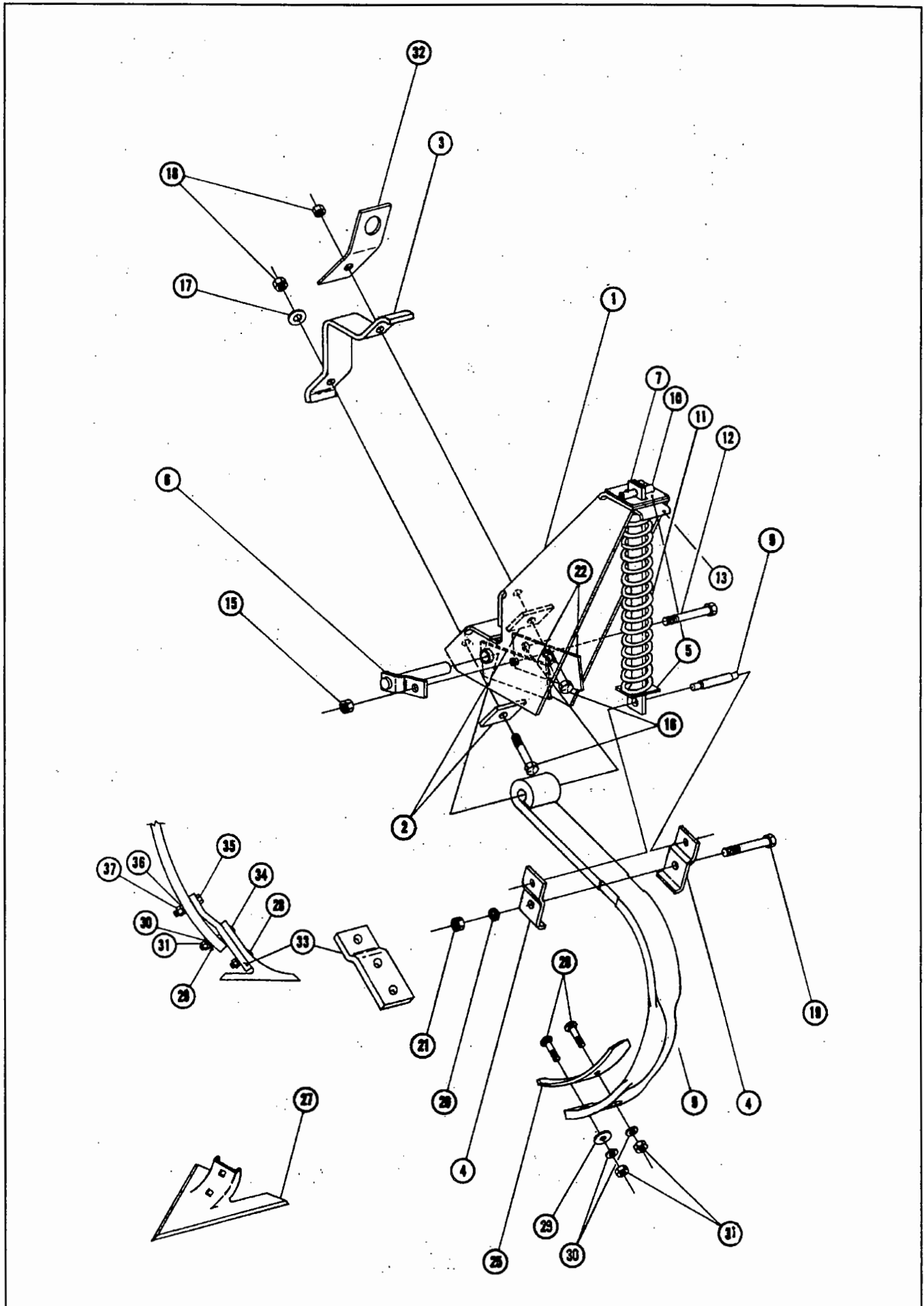

# SPRING SHANK ASSEMBLY

FOR MODELS – ALL

12/89

Item	Part Number	Part Description	Qty.
	3127-25-0B	Spring Shank Assembly	1
1	3127-24-0	Mounting Channel (For Repairs only)	1
2	★ 3127-25-3	Doubler	2
3	★ 3127-25-5	Mounting Strap	1
4	3127-25-8	Shank Clamp	2
5	3127-39-2	Slotted Washer	2
6	3127-37-0A	Pin Assembly	1
7	3127-39-1A	Guide Bar	1
8	31-157	Edge-On Shank	1
9	60-105	Pivot Pin	1
10	60-624	1/2" DIA. x 2" Roll Pin	1
11	76-134	Spring	1
12	62-462	1/2NC x 3-1/2" Cap Screw	1
13	3127-24-2A	Slot Doubler	1
14			
15	63-107	1/2NC Self Locking Nut	1
16	★ 62-550	1/2NC x 2" GRADE 8 Cap Screw	2
17	★ 64-108	1/2" STD. Flat Washer	1
18	★ 63-107	1/2NC Self Locking Nut	2
19	62-148	1/2NC x 2-3/4" Cap Screw	1
20	64-107	1/2" STD. Lock Washer	1
21	63-106	1/2NC Hex Nut	1
22	3127-25-7	Shank Guide	2
23			
24			
25	★ 33-100	Point	1
26			
27	★ 33-101	9" Sweep 47° Stem Angle	1
	★ 33-119	10" Sweep 47° Stem Angle	1
28	★ 62-112	3/8NC x 1-1/2" GRADE 5 #3 Plow Bolt	3
29	★ 64-104	3/8" STD. Flat Washer	1
30	★ 64-103	3/8" STD. Lock Washer	3
31	★ 63-102	3/8NC Hex Nut	3
32	★ 4122-0-14	Winch Bracket (Shown in storage position)	1
	★ 4100-10-0	Extension Shank and Bolt Assembly	1
33	★ 4100-0-9	Extension Shank	1
34	★ 62-406	3/8NC x 2-1/4" GD. 5 #3 Plow Bolt	1
35	★ 62-407	7/16NC x 1-1/2" GD. 5 Cap Screw	1
36	★ 64-105	7/16" STD. Lock Washer	1
37	★ 63-104	7/16NC Hex Nut	1
38	★ 64-104	3/8" STD. Flat Washer	1
39	★ 64-103	3/8" STD. Lock Washer	1
40	★ 63-102	3/8NC Hex Nut	1
★ Not Part of 3127-25-0B Spring Shank Assembly			

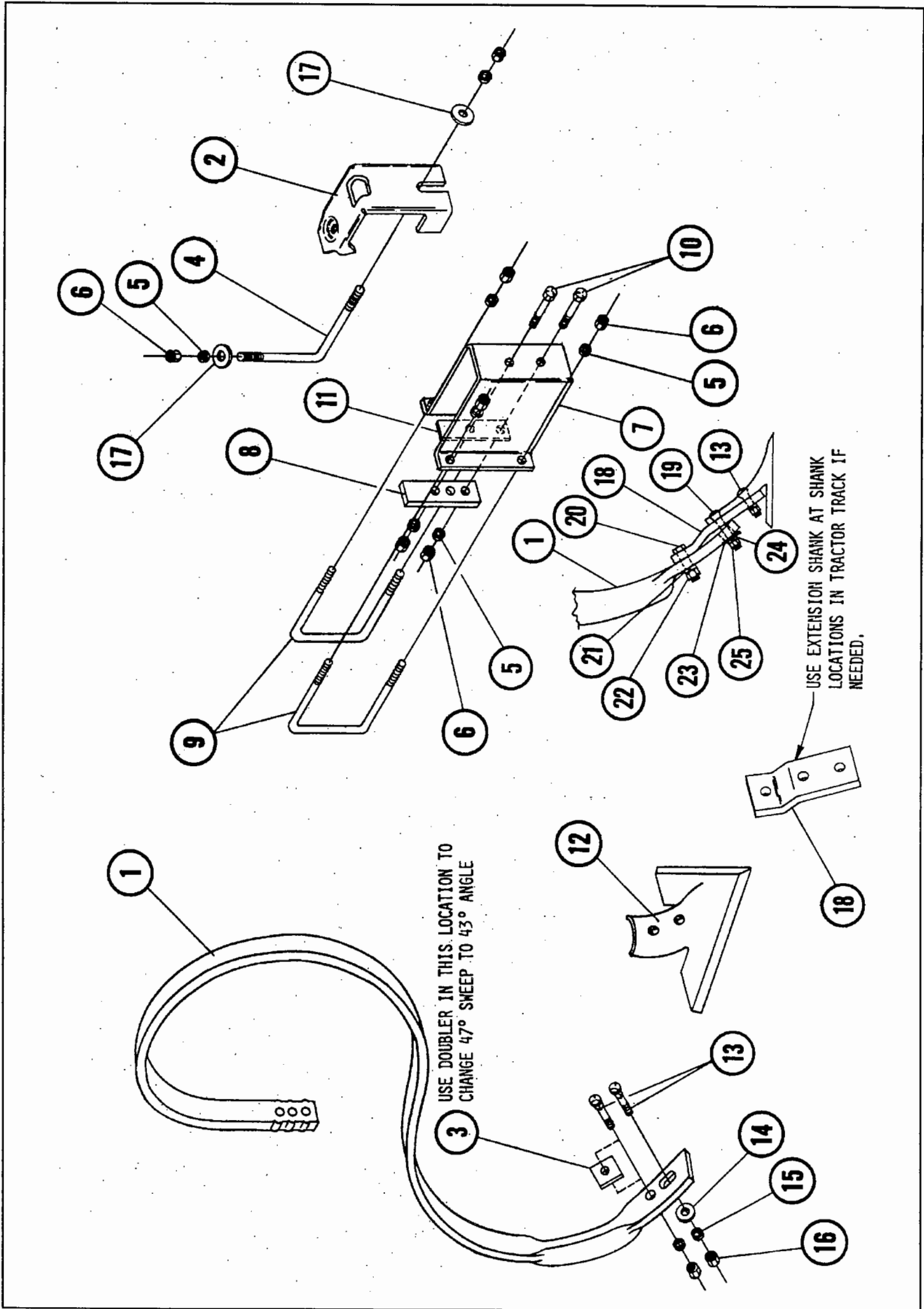



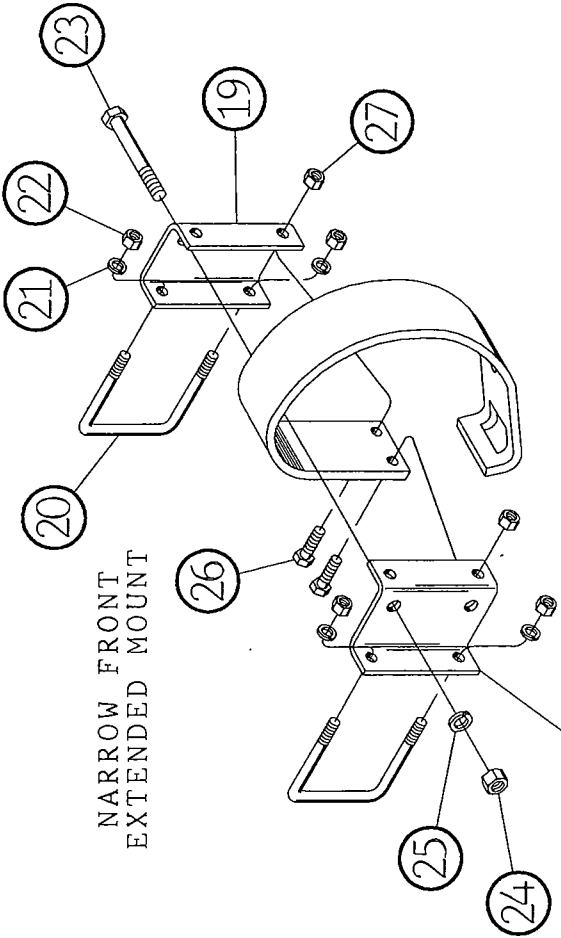

NARROW FRONT  
EXTENDED MOUNT

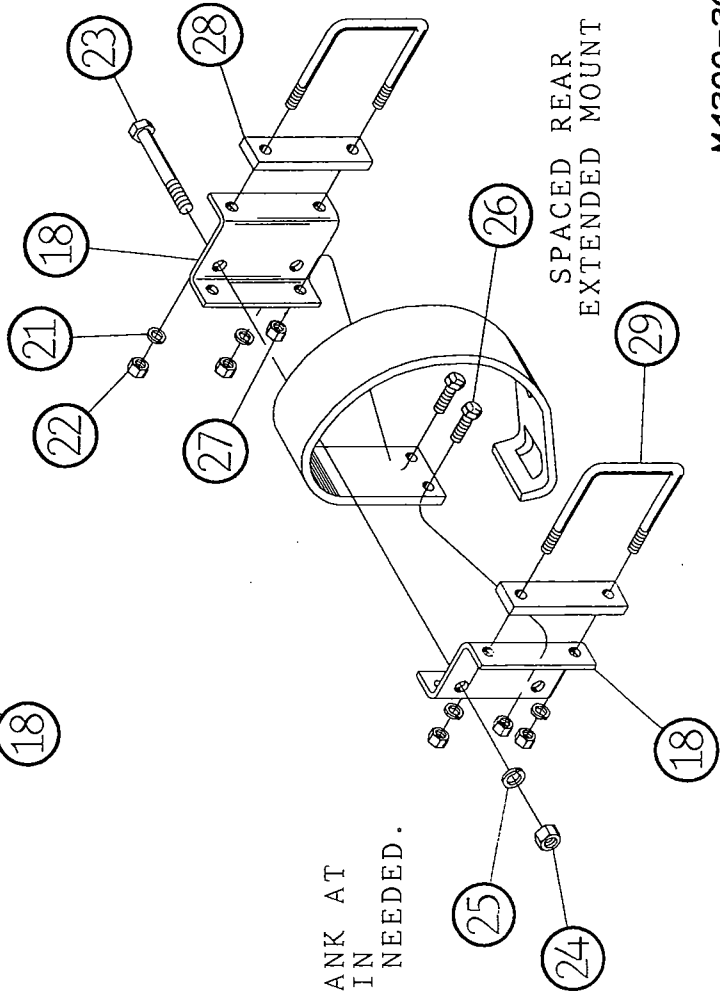

SPACED REAR  
EXTENDED MOUNT

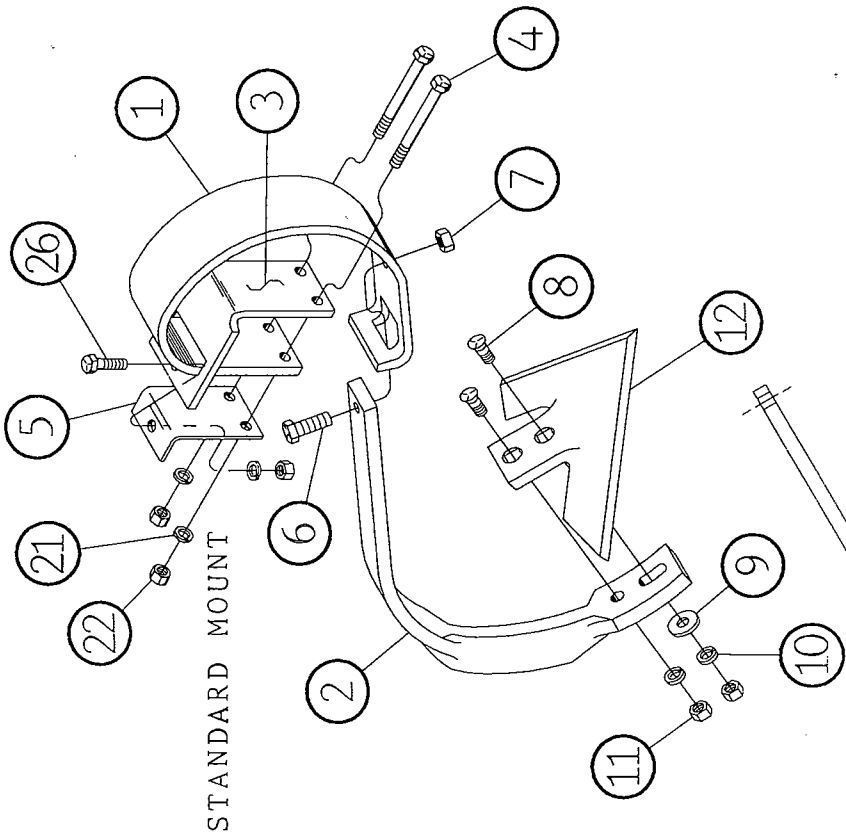

STANDARD MOUNT

USE EXTENSION SHANK AT  
SHANK LOCATIONS IN  
TRACTOR TRACK IF NEEDED.

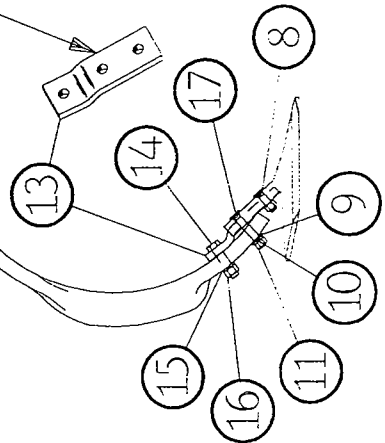



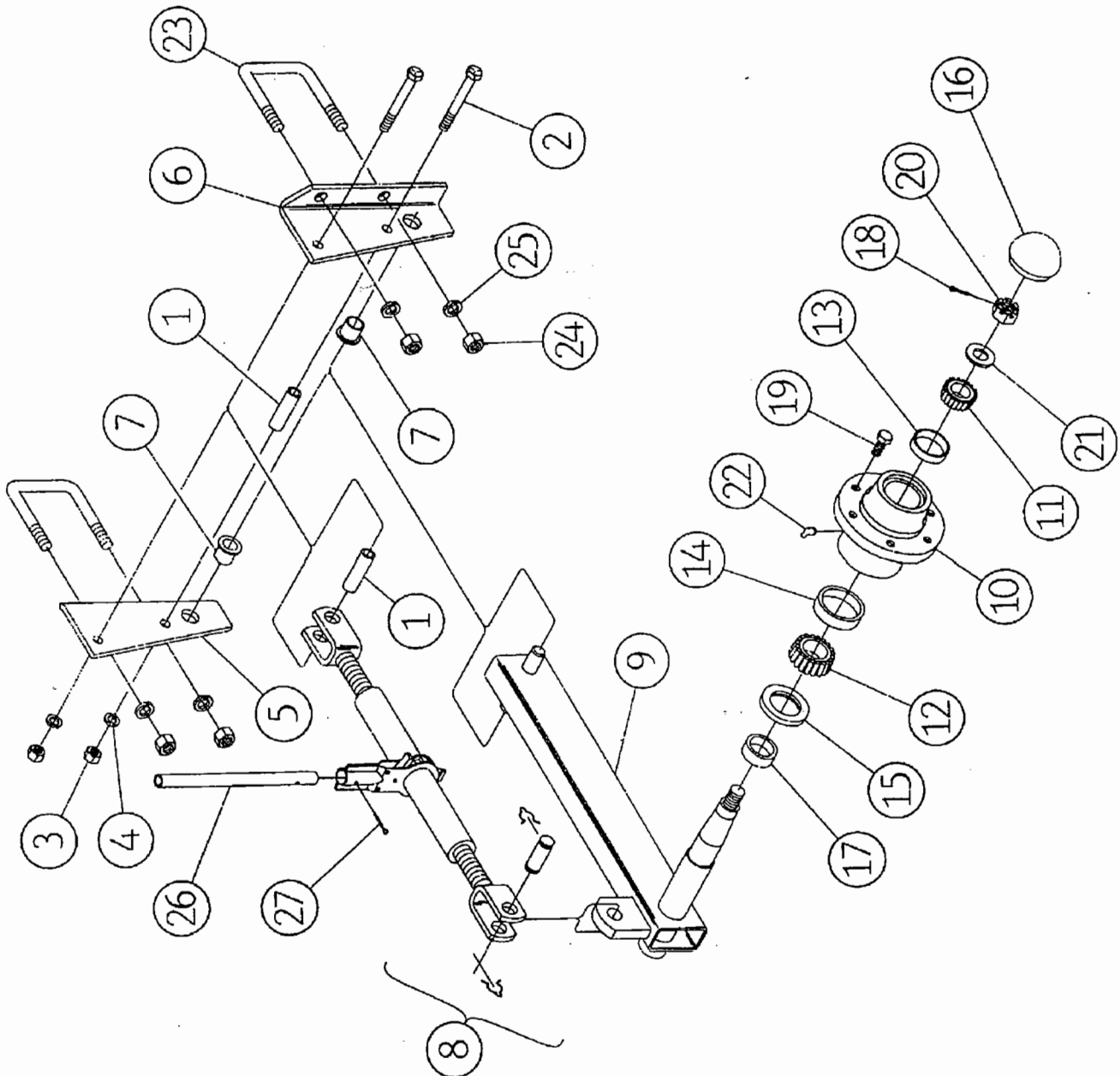



# PACKER HITCH ASSEMBLY

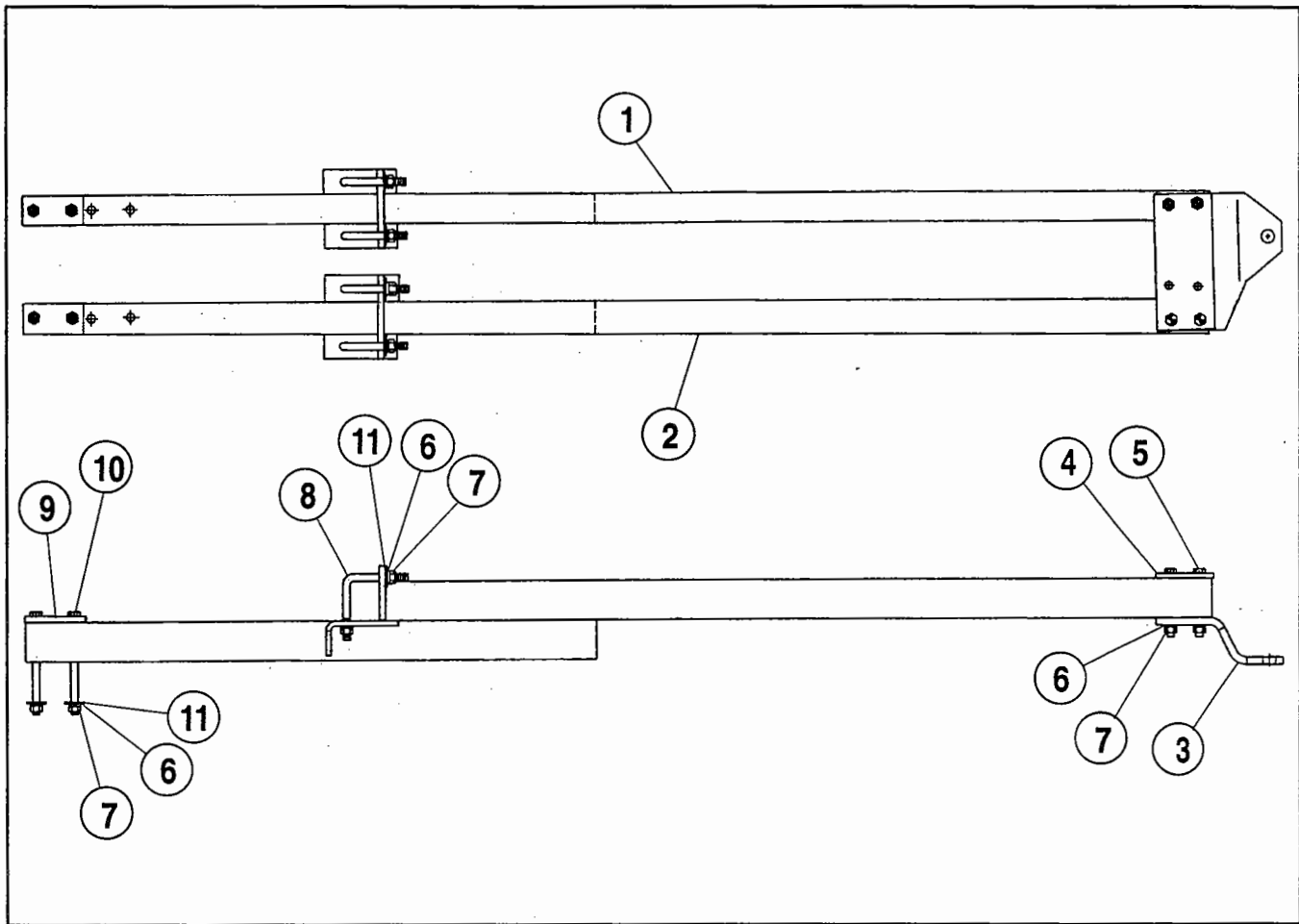

**FOR MODELS – Accessory for all models**

**9/92**

Item	Part Number	Part Description	Qty.
	☆ 4223-400-0	Packer Hitch Assembly	1
	○ 4226-400-0	Packer Hitch Assembly	1
1	4223-410-0	Right Hitch Box Weldment	1
2	4223-411-0	Left Hitch Box Weldment	1
3	☆ 4223-400-2	Drop Plate	1
	○ 6112-400-2	Drop Plate	1
4	☆ 4223-400-1	Bolt Plate	1
	○ 6112-400-1	Bolt Plate	1
5	62-213	3/4NC x 6-1/2" GD. 5 Cap Screw	4
6	64-112	3/4" STD. Lock Washer	16
7	63-112	3/4NC Hex Nut	16
8	61-221	3/4" DIA. L-Bolt	4
9	3127-571-1	Bolt Plate	2
10	62-224	3/4NC x 10" Machine Bolt	4
11	64-113	3/4" STD. Flat Washer	8
☆ Used for Models 4218, 4223			
○ Used for Models 4226, 4231, 4237 and 4241			

# TRAIL HITCH ASSEMBLY

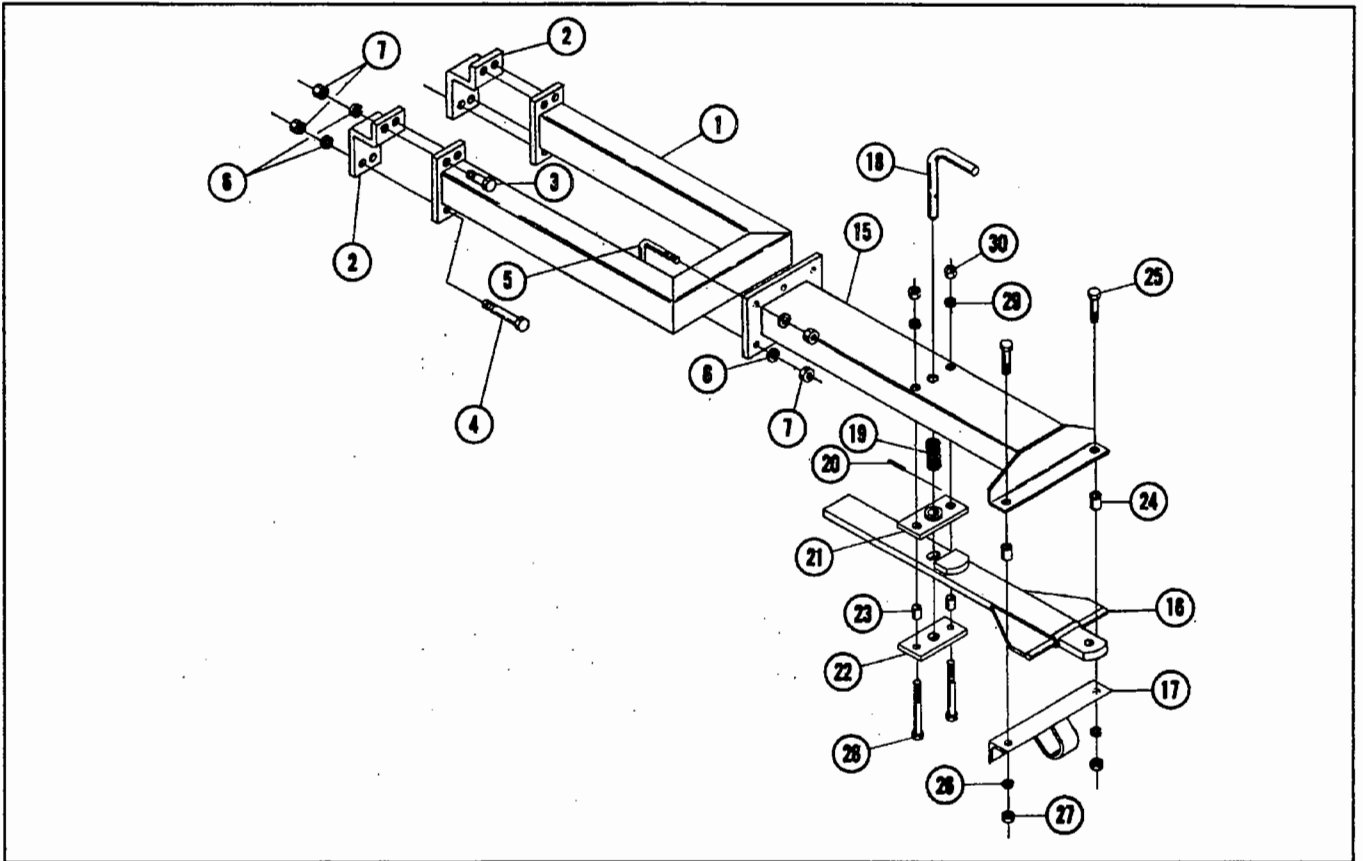

FOR MODELS - 4238, 4241

4/90

Item	Part Number	Part Description	Qty.
	4100-313-0	Hitch Extension Assembly	1
1	3755-310-0	Hitch Extension Weldment	1
2	4100-313-1	Mounting Plate	2
3	62-168	5/8NC x 2" Cap Screw	4
4	62-181	5/8NC x 5" Cap Screw	4
5	61-126	5/8" DIA. U-Bolt	3
6	64-109	5/8" STD. Lock Washer	14
7	63-109	5/8NC Hex Nut	14
	3755-302-0	Hitch Assembly	1
15	3755-303-0	Hitch Frame Weldment	1
16	3755-304-0	Swing Tongue Weldment	1
17	3755-307-0	Angle Support Weldment	1
18	3755-302-1	Spring Pin	1
19	76-137	Spring	1
20	60-606	1/4" DIA. x 2" Roll Pin	1
21	3755-305-0	Pin Guide Weldment	1
22	3755-302-2	Pin Guide	1
23	3755-302-3	Spacer	2
24	3755-302-4	Spacer	2
25	62-194	3/4NC x 2-1/2" Cap Screw	2
26	64-112	3/4" STD. Lock Washer	2
27	63-112	3/4NC Hex Nut	2
28	62-185	5/8NC x 6" Cap Screw	2
29	64-109	5/8" STD. Lock Washer	2
30	63-109	5/8NC Hex Nut	2

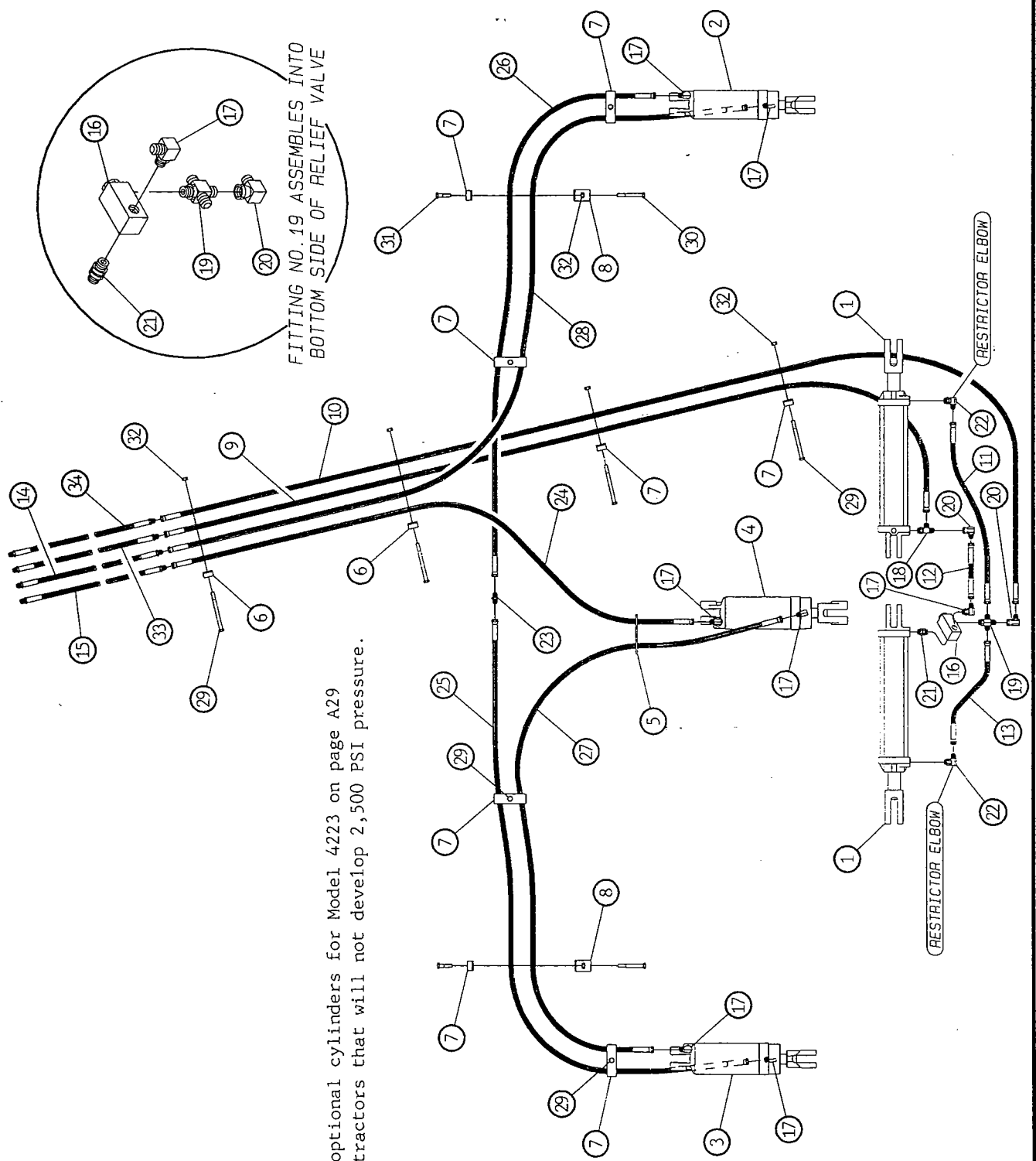

FITTING NO. 19 ASSEMBLES INTO  
BOTTOM SIDE OF RELIEF VALVE

NOTE: See optional cylinders for Model 4223 on page A29  
for tractors that will not develop 2,500 PSI pressure.



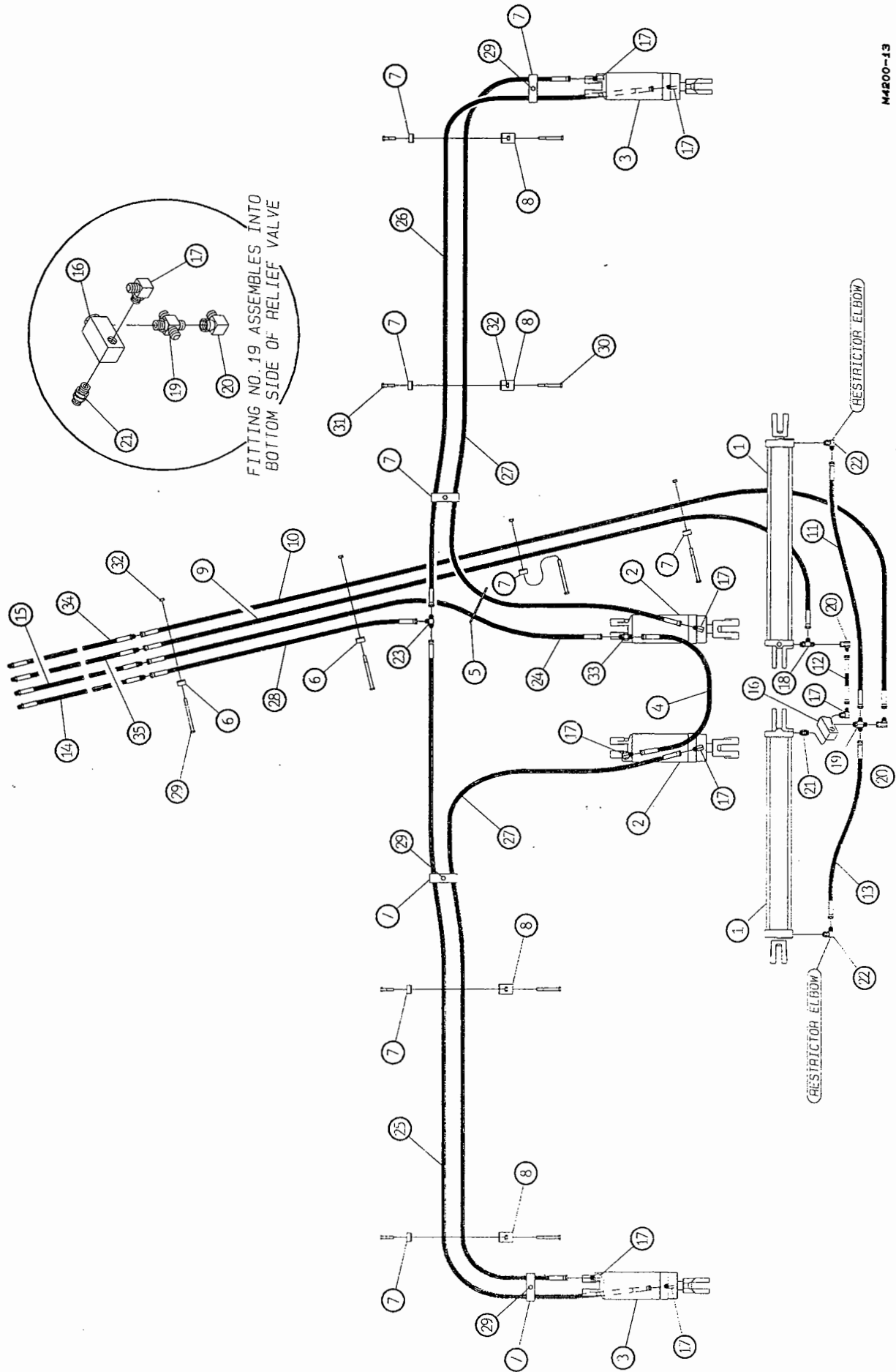



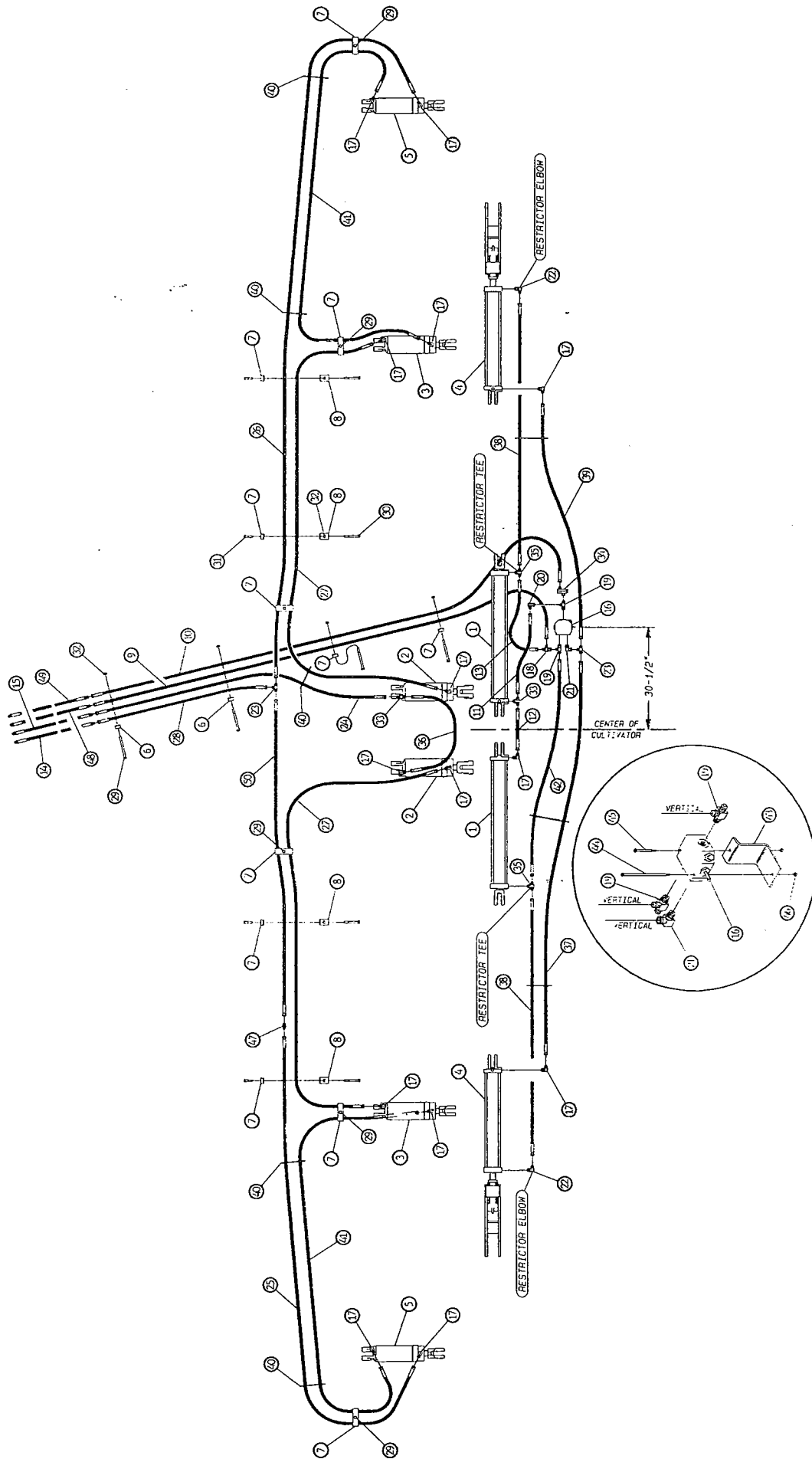

## HYDRAULIC HOSE GROUP – Model 4237

3/94

Item	Part Number	Part Description	Qty.
1	21-107	Prince Hydraulic Cylinder 4" x 32"	2
2	22-126	Eaton Hydraulic Series Cylinder 4-1/2" x 8"	2
3	22-125	Eaton Hydraulic Series Cylinder 4-1/4" x 8"	2
4	4241-80-0	Outer Wing Lift Cylinder Assembly 4" x 24"	2
5	22-122	Eaton Hydraulic Series Cylinder 4" x 8"	2
6	2426-170-5	Hose Clamp	2
7	3514-0-2	Hose Clamp	12
8	4122-0-1	Hose Bracket	4
9	24-234	Hose 3/8" DIA. x 207" (3/4" Swivel Both Ends)	1
10	24-248	Hose 3/8" DIA. x 214" (3/4" Swivel Both Ends)	1
11	24-246	Hose 3/8" DIA. x 28" (3/4" Swivel Both Ends)	1
12	24-264	Hose 3/8" DIA. x 13" (3/4" Swivel Both Ends)	1
13	24-266	Hose 3/8" DIA. x 21" (3/4" Swivel Both Ends)	1
14	● 4990-75-0	Hose 1/2" DIA. x 92" with Red/Red Grip	1
15	● 4990-76-0	Hose 1/2" DIA. x 92" with Yellow/Yellow Grip	1
16	25-144	Sequence Valve	1
17	25-301	O-Ring 37° Flare 90° Adapter	14
18	25-307	37° Flare Male / Female Tee	1
19	25-302	O-Ring 37° Flare Tee	2
20	25-310	37° Flare Male / Female 90° Elbow	1
21	25-320	O-Ring 37° Flare 90° Female Elbow	1
22	4956-75-0	O-Ring 37° 90° Restrictor (YELLOW)	2
23	25-303	37° Flare Male Tee	2
24	24-329	Hose 1/2" DIA. x 157" (3/4" Swivel Both Ends)	1
25	24-228	Hose 3/8" DIA. x 149" (3/4" Swivel Both Ends)	1
26	24-248	Hose 3/8" DIA. x 214" (3/4" Swivel Both Ends)	1
27	24-234	Hose 3/8" DIA. x 207" (3/4" Swivel Both Ends)	2
28	24-336	Hose 1/2" DIA. x 98" (3/4" Swivel Both Ends)	1
29	62-159	1/2NC x 6" Cap Screw	10
30	62-155	1/2NC x 4" Cap Screw	4
31	62-142	1/2NC x 2" Cap Screw	4
32	63-107	1/2NC Self Locking Nut	18
33	25-309	O-Ring 37° Flare Male Tee	2
34	25-324	37° Flare Male / Female In-Line Restrictor	1
35	3775-75-0	O-Ring 37° Flare Male Tee Restrictor (YELLOW)	2
36	24-380	Hose 1/2" DIA. x 33" (3/4" Swivel Both Ends)	1
37	24-265	Hose 3/8" DIA. x 135" (3/4" Swivel Both Ends)	1
38	24-236	Hose 3/8" DIA. x 98" (3/4" Swivel Both Ends)	2
39	24-212	Hose 3/8" DIA. x 79" (3/4" Swivel Both Ends)	1
40	25-126	Panduit Stay Strap (Use as needed)	8
41	24-329	Hose 1/2" DIA. x 157" (3/4" Swivel Both Ends)	2
42	24-210	Hose 3/8" DIA. x 74" (3/4" Swivel Both Ends)	1
43	4241-0-3	Mounting Bracket	1
44	62-512	1/4NC x 6-1/2" GRADE 5 Cap Screw	1
45	62-513	1/4NC x 2-3/4" GRADE 5 Cap Screw	1
46	63-101	1/4NC Self Locking Nut	2
47	25-304	37° Flare Male Coupler	1
48	● 4990-77-0	3/8" x 92" Hose with Red/Black Grip	1
49	● 4990-78-0	3/8" x 92" Hose with Yellow/Black Grip	1
50	24-237	3/8" x 122" Hose (3/4" Swivel Both Ends)	1

● See page P58 for parts listing

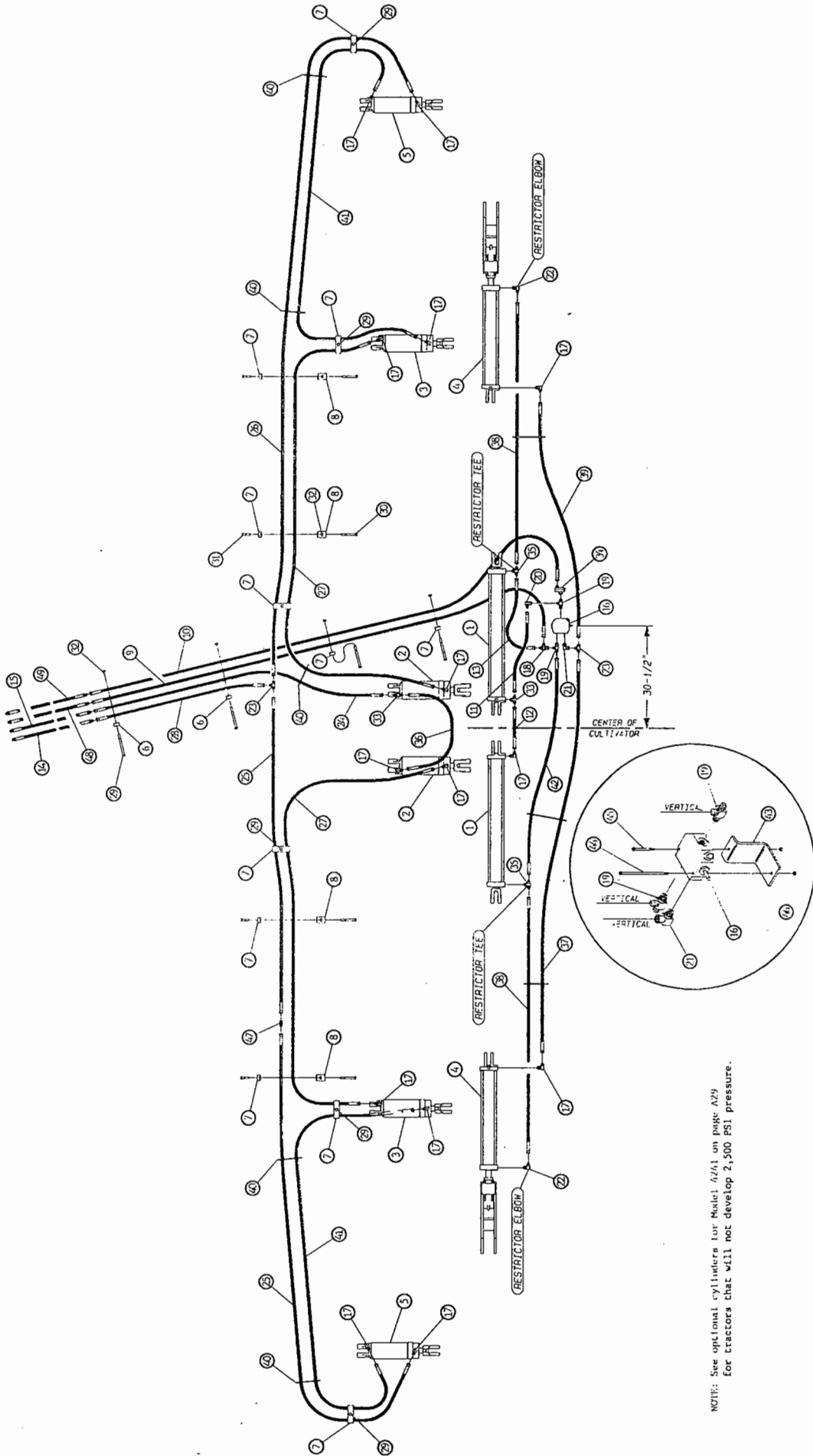

NOTE: See optional cylinders for Model 6241 on page A29 for tractors that will not develop 2,500 PSI pressure.

# HYDRAULIC HOSE GROUP

FOR MODELS – 4241

3/94

Item	Part Number	Part Description	Qty.
1	21-107	Prince Hydraulic Cylinder 4" x 32"	2
2	22-126	Eaton Hydraulic Series Cylinder 4-1/2" x 8"	2
3	22-125	Eaton Hydraulic Series Cylinder 4-1/4" x 8"	2
4	4241-80-0	Outer Wing Lift Cylinder Assembly 4" x 24"	2
5	22-122	Eaton Hydraulic Series Cylinder 4" x 8"	2
6	2426-170-5	Hose Clamp	2
7	3514-0-2	Hose Clamp	12
8	4122-0-1	Hose Bracket	4
9	24-234	Hose 3/8" DIA. x 207" (3/4" Swivel Both Ends)	1
10	24-248	Hose 3/8" DIA. x 214" (3/4" Swivel Both Ends)	1
11	24-246	Hose 3/8" DIA. x 28" (3/4" Swivel Both Ends)	1
12	24-264	Hose 3/8" DIA. x 13" (3/4" Swivel Both Ends)	1
13	24-266	Hose 3/8" DIA. x 21" (3/4" Swivel Both Ends)	1
14	● 4990-75-0	Hose 1/2" DIA. x 92" with Red/Red Grip	1
15	● 4990-76-0	Hose 1/2" DIA. x 92" with Yellow/Yellow Grip	1
16	25-144	Sequence Valve	1
17	25-301	O-Ring 37° Flare 90° Adapter	14
18	25-307	37° Flare Male / Female Tee	1
19	25-302	O-Ring 37° Flare Tee	2
20	25-310	37° Flare Male / Female 90° Elbow	1
21	25-320	O-Ring 37° Flare 90° Female Elbow	1
22	4956-75-0	O-Ring 37° 90° Restrictor (YELLOW)	2
23	25-303	37° Flare Male Tee	2
24	24-329	Hose 1/2" DIA. x 157" (3/4" Swivel Both Ends)	1
25	24-228	Hose 3/8" DIA. x 149" (3/4" Swivel Both Ends)	2
26	24-260	Hose 3/8" DIA. x 243" (3/4" Swivel Both Ends)	1
27	24-356	Hose 1/2" DIA. x 233" (3/4" Swivel Both Ends)	2
28	24-336	Hose 1/2" DIA. x 98" (3/4" Swivel Both Ends)	1
29	62-159	1/2NC x 6" Cap Screw	10
30	62-155	1/2NC x 4" Cap Screw	4
31	62-142	1/2NC x 2" Cap Screw	4
32	63-107	1/2NC Self Locking Nut	18
33	25-309	O-Ring 37° Flare Male Tee	2
34	25-324	37° Flare Male / Female In-Line Restrictor	1
35	3775-75-0	O-Ring 37° Flare Male Tee Restrictor (YELLOW)	2
36	24-380	Hose 1/2" DIA. x 33" (3/4" Swivel Both Ends)	1
37	24-242	Hose 3/8" DIA. x 161" (3/4" Swivel Both Ends)	1
38	24-222	Hose 3/8" DIA. x 125" (3/4" Swivel Both Ends)	2
39	24-240	Hose 3/8" DIA. x 107" (3/4" Swivel Both Ends)	1
40	25-126	Panduit Stay Strap (Use as needed)_	8
41	24-329	Hose 1/2" DIA. x 157" (3/4" Swivel Both Ends)	2
42	24-210	Hose 3/8" DIA. x 74" (3/4" Swivel Both Ends)	1
43	4241-0-3	Mounting Bracket	1
44	62-512	1/4NC x 6-1/2" GD. 5 Cap Screw	1
45	62-513	1/4NC x 2-3/4" GD. 5 Cap Screw	1
46	63-101	1/4NC Self Locking Nut	2
47	25-304	37° Flare Male Coupler	1
48	● 4990-77-0	3/8" x 92" Hose Assembly with Red/Black Grip	1
49	● 4990-78-0	3/8" x 92" Hose Assembly with Yellow/Black Grip	1

● See page P58 for parts listing

# HYDRAULIC HOSE WITH PLASTIC GRIP ASSEMBLIES

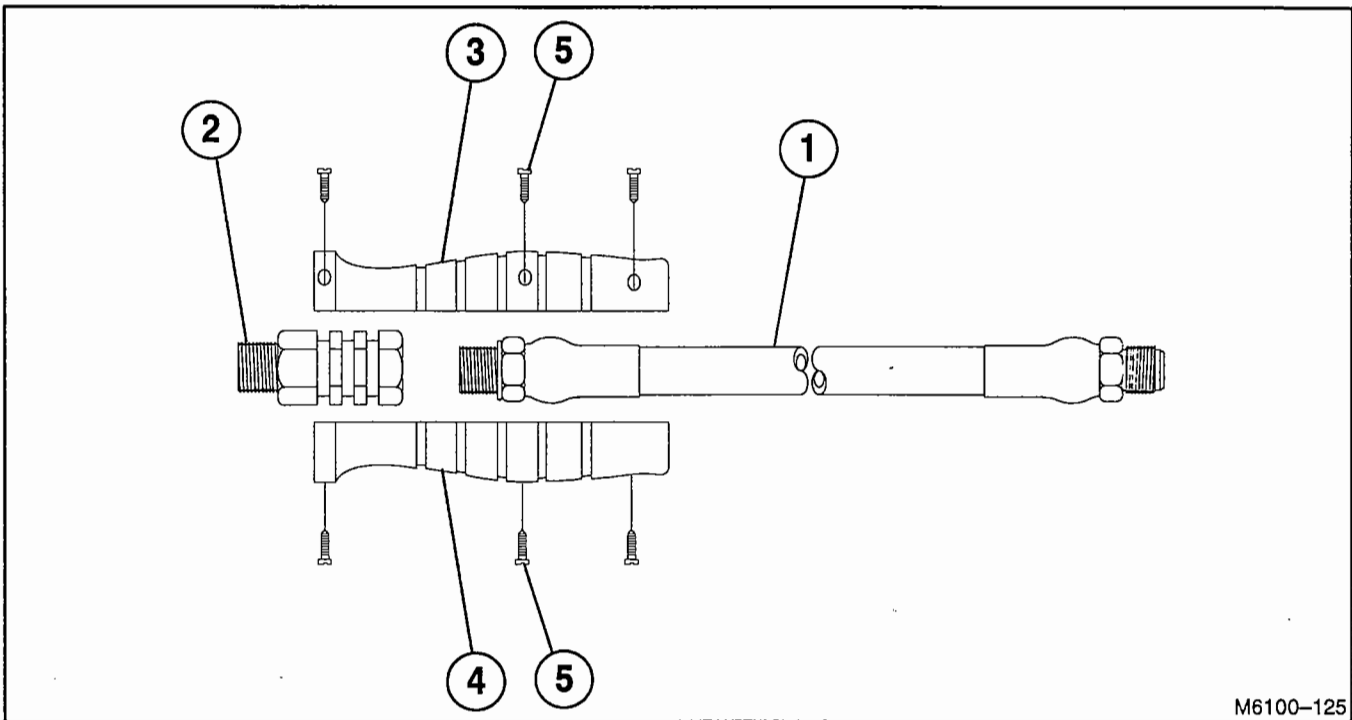

M6100-125

## FOR MODELS - 4241

3/94

Item	Part Number	Part Description	Qty.
	4990-75-0	1/2" x 92" 100R2 Hose with Red/Red Grip Assembly	1
1	24-330	1/2" DIA. x 92" JIC/ORB 100R2 Hose	1
2	25-2295	3/4 ORB to 1/2 NPT Hydraulic Fitting	1
3	25-2289	Hose Grip Half - Red	1
4	25-2289	Hose Grip Half - Red	1
5	62-656	Screw	6
	4990-76-0	1/2" x 92" 100R2 Hose with Yellow/Yellow Grip Assembly	1
1	24-330	1/2" DIA. x 92" JIC/ORB 100R2 Hose	1
2	25-2295	3/4 ORB to 1/2 NPT Hydraulic Fitting	1
3	25-2290	Hose Grip Half - Yellow	1
4	25-2290	Hose Grip Half - Yellow	1
5	62-656	Screw	6
	4990-77-0	3/8" x 92" 100R2 Hose with Red/Black Grip Assembly	1
1	24-2105	3/8" DIA. x 92" JIC/ORB 100R2 Hose	1
2	25-2295	3/4 ORB to 1/2 NPT Hydraulic Fitting	1
3	25-2289	Hose Grip Half - Red	1
4	25-2291	Hose Grip Half - Black	1
5	62-656	Screw	6
	4990-78-0	3/8" x 92" 100R2 Hose with Yellow/Black Grip Assembly	1
1	24-2105	3/8" Dia. x 92" JIC/ORB 100R2 Hose	1
2	25-2295	3/4 ORB to 1/2 NPT Hydraulic Fitting	1
3	25-2290	Hose Grip Half - Yellow	1
4	25-2291	Hose Grip Half - Black	1
5	62-656	Screw	6

# EATON HYDRAULIC CYLINDER ASSEMBLY

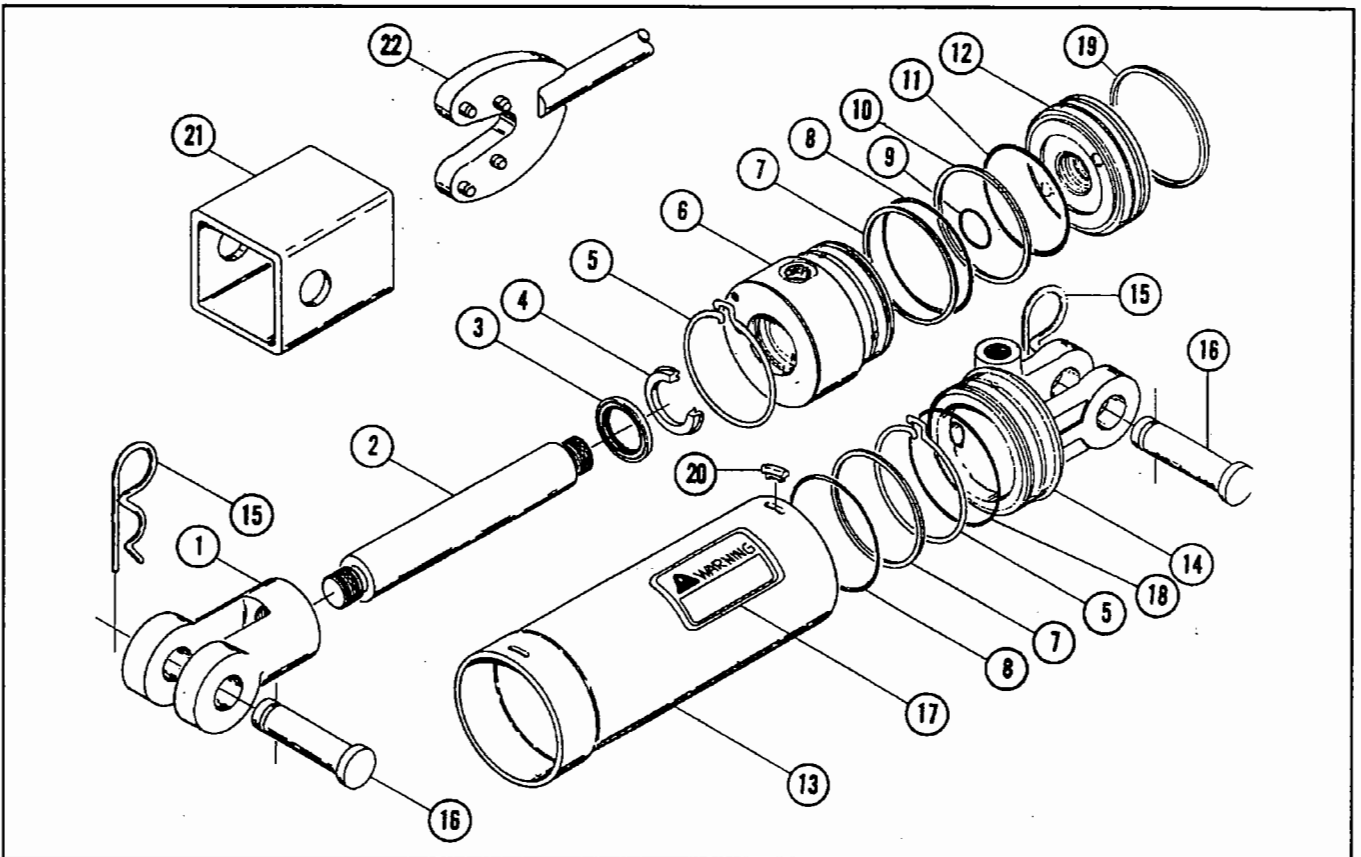

**FOR 22-122 4" X 8" Eaton Hydraulic Cylinder Assembly (Retract Series)**  
**Retracted - 20-1/4"      Extended - 28-1/4"      Stroke - 8"      Rod Diameter - 1-3/8"**

**12/89**

Item	Part Number	Part Description	Qty.
1	22-413	Rod End	1
2	22-414	Piston Rod	1
3	★ 22-276	Wiper Seal	1
4	★ 22-277	U-Cup Seal	1
5	★ 22-417	Lock Ring	2
6	22-415	Bearing	1
7	★ 22-215	Back-Up Washer	2
8	★ 22-213	O-Ring	2
9	★ 22-282	O-Ring	1
10	★ 22-291	Slipper Ring	1
11	★ 22-214	O-Ring	1
12	22-380	Piston	1
13	22-382	Barrel	1
14	22-381	Head	1
15	22-234	Spring Locking Pin	2
16	22-273	Clevis Pin	2
17	74-113	Cylinder WARNING Decal	1
18	22-416	O-Ring Dust Seal	2
19	★ 22-383	Wear Ring	1
20	★ 22-400	Slot Cover	2
	4901-79-0	Eaton Cylinder Tool Kit - Not included in cylinder assembly	1
21		Clevis Stop	1
22		Spanner Wrench	1
	22-418	Seal Kit (★ Items Included In Kit) - Not included in cylinder assembly	

**NOTE CYLINDER REPHASES WHEN IT IS FULLY RETRACTED**

# EATON HYDRAULIC CYINDER ASSEMBLY

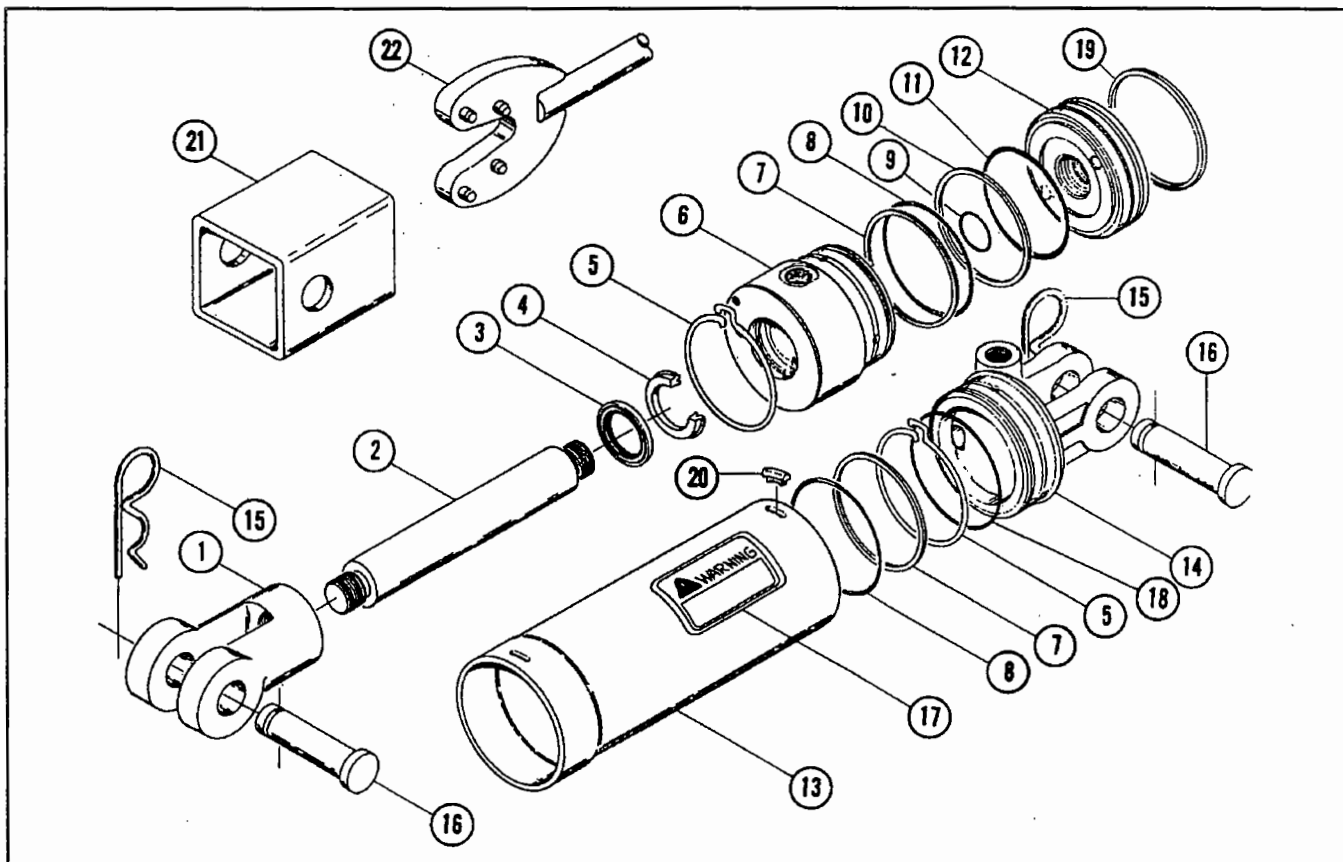

**FOR 22-125 4-1/4" X 8" Eaton Hydraulic Cylinder Assembly (Retract Series) 12/89**  
**Retracted - 20-1/4"    Extended - 28-1/4"    Stroke - 8"    Rod Diameter - 1-1/2"**

Item	Part Number	Part Description	Qty.
1	22-393	Rod End	1
2	22-397	Piston Rod	1
3	★ 22-316	Wiper Seal	1
4	★ 22-319	U-Cup Seal	1
5	★ 22-398	Lock Ring	2
6	22-395	Bearing	1
7	★ 22-327	Back-Up Washer	2
8	★ 22-326	O-Ring	2
9	★ 22-312	O-Ring	1
10	★ 22-329	Slipper Ring	1
11	★ 22-325	O-Ring	1
12	22-394	Piston	1
13	22-396	Barrel	1
14	22-393	Head	1
15	22-234	Spring Locking Pin	2
16	22-303	Clevis Pin	2
17	74-113	Cylinder WARNING Decal	1
18	22-401	O-Ring Dust Seal	2
19	★ 22-399	Wear Ring	1
20	★ 22-400	Slot Cover	2
	4901-79-0	Eaton Cylinder Tool Kit - Not included in cylinder assembly	1
21		Clevis Stop	1
22		Spanner Wrench	1
	22-411	Seal Kit ( ★ Items Included In Kit) - Not included in cylinder assembly	

**NOTE: CYLINDER REPHASES WHEN IT IS FULLY RETRACTED.**

# EATON HYDRAULIC CYLINDER ASSEMBLY

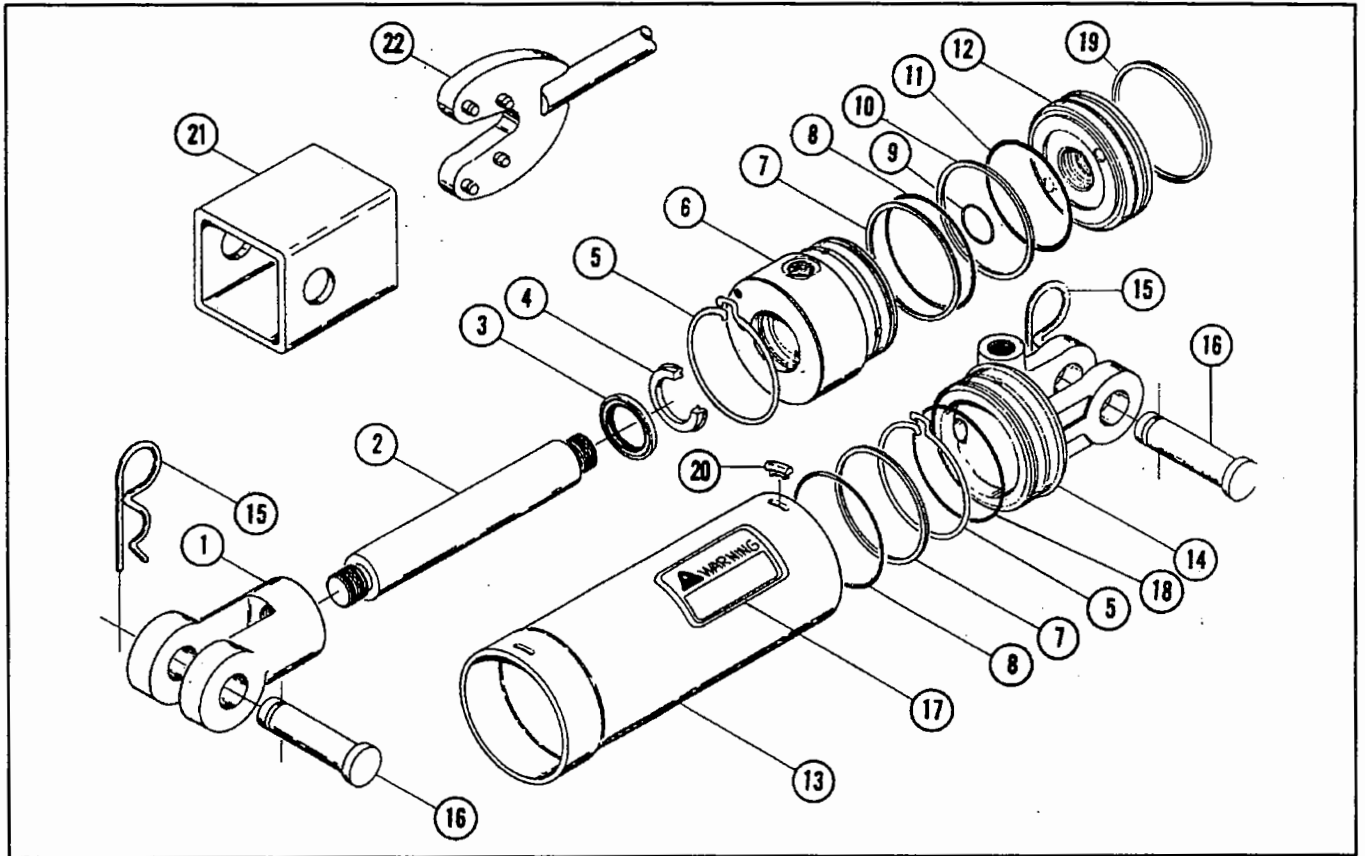

**FOR 22-126 4-1/2" X 8" Eaton Hydraulic Cylinder Assembly (Retract Series)**  
**Retracted - 20-1/4"    Extended - 28-1/4"    Stroke - 8"    Rod Diameter - 1-1/2"**

3/94

Item	Part Number	Part Description	Qty.
1	22-575	Rod End (2-3/4" Wide)	1
2	22-397	Piston Rod	1
3	★ 22-316	Wiper Seal	1
4	★ 22-319	U-Cup Seal	1
5	★ 22-407	Lock Ring	2
6	22-405	Bearing	1
7	★ 22-315	Back-Up Washer	2
8	★ 22-314	O-Ring	2
9	★ 22-312	O-Ring	1
10	★ 22-318	Slipper Ring	1
11	★ 22-313	O-Ring	1
12	22-404	Piston	1
13	22-406	Barrel	1
14	22-403	Head	1
15	22-234	Spring Locking Pin	2
16	22-303	Clevis Pin	2
17	74-113	Cylinder WARNING Decal	1
18	22-410	O-Ring Dust Seal	2
19	★ 22-408	Wear Ring	1
20	★ 22-400	Slot Cover	2
	4901-79-0	Eaton Cylinder Tool Kit - Not included in cylinder assembly	1
21		Clevis Stop	1
22		Spanner Wrench	1
	22-412	Seal Kit (★ Items Included In Kit) - Not included in cylinder assembly	

NOTE: CYLINDER REPHASES WHEN IT IS FULLY RETRACTED.

# PRINCE HYDRAULIC CYLINDER ASSEMBLY

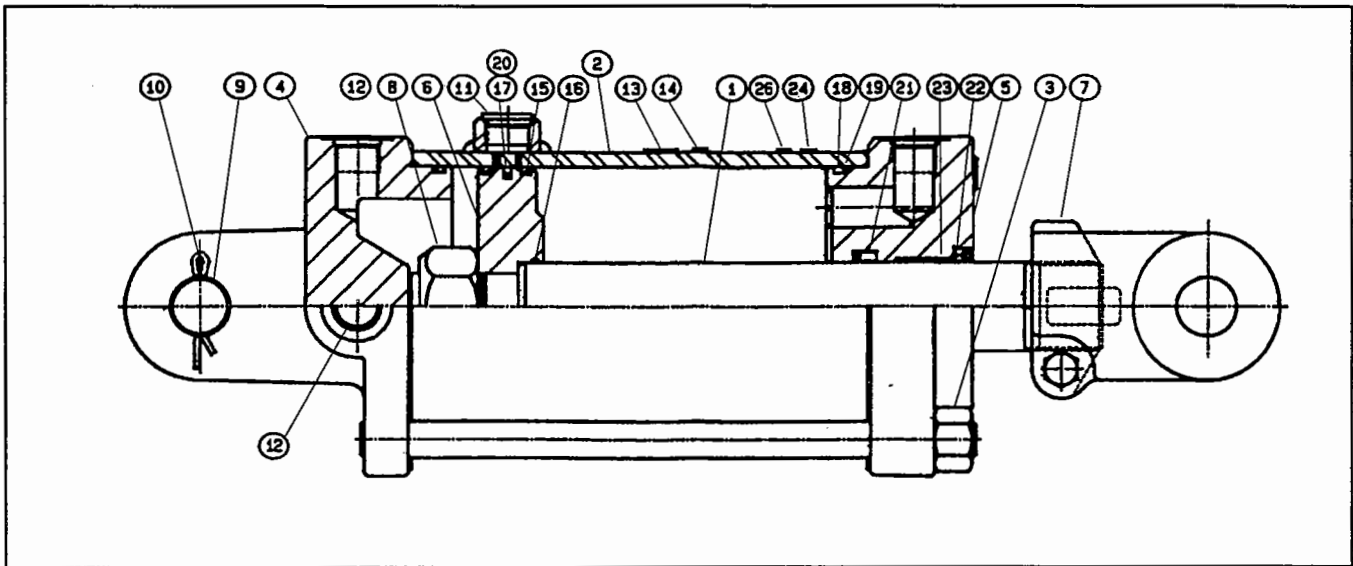

**FOR 21-163 4-3/4" X 8" Prince Hydraulic Cylinder Assembly** 9/92  
**Retracted - 20-1/4"    Extended - 28-1/4"    Stroke - 8"    Rod Diameter - 1-1/2"**

Item	Part Number	Part Description	Qty.
1	21-814	Piston Rod	1
2	21-815	Tube Assembly	1
3	21-715	Tie Rod Assembly	4
4	21-816	Butt Assembly	1
5	21-817	Gland Assembly	1
6	21-818	Piston	1
7	21-506	Clevis Assembly	1
8	21-819	Lock Nut	1
9	21-696	Clevis Pin	1
10	21-639	Cotter Pin	2
11	21-820	Port Plug	1
12	21-831	Port Plug	1
13	21-444	Decal	1
14	21-443	Decal	1
15	★ 21-822	Bearing Ring	2
16	★ 21-823	O-Ring	1
17	★ 21-824	O-Ring	1
18	★ 21-825	O-Ring	2
19	★ 21-826	Back-Up Washer	2
20	★ 21-827	Teflon Seal	1
21	★ 21-350	U-Cup	1
22	★ 21-749	Wiper	1
23	21-828	Bushing	1
24	74-113	Cylinder Pin Warning Decal	1
26	21-830	Seal Kit Decal	1
		Seal Kit ( ★ Items Included In Kit)	

# PRINCE HYDRAULIC CYLINDER ASSEMBLY

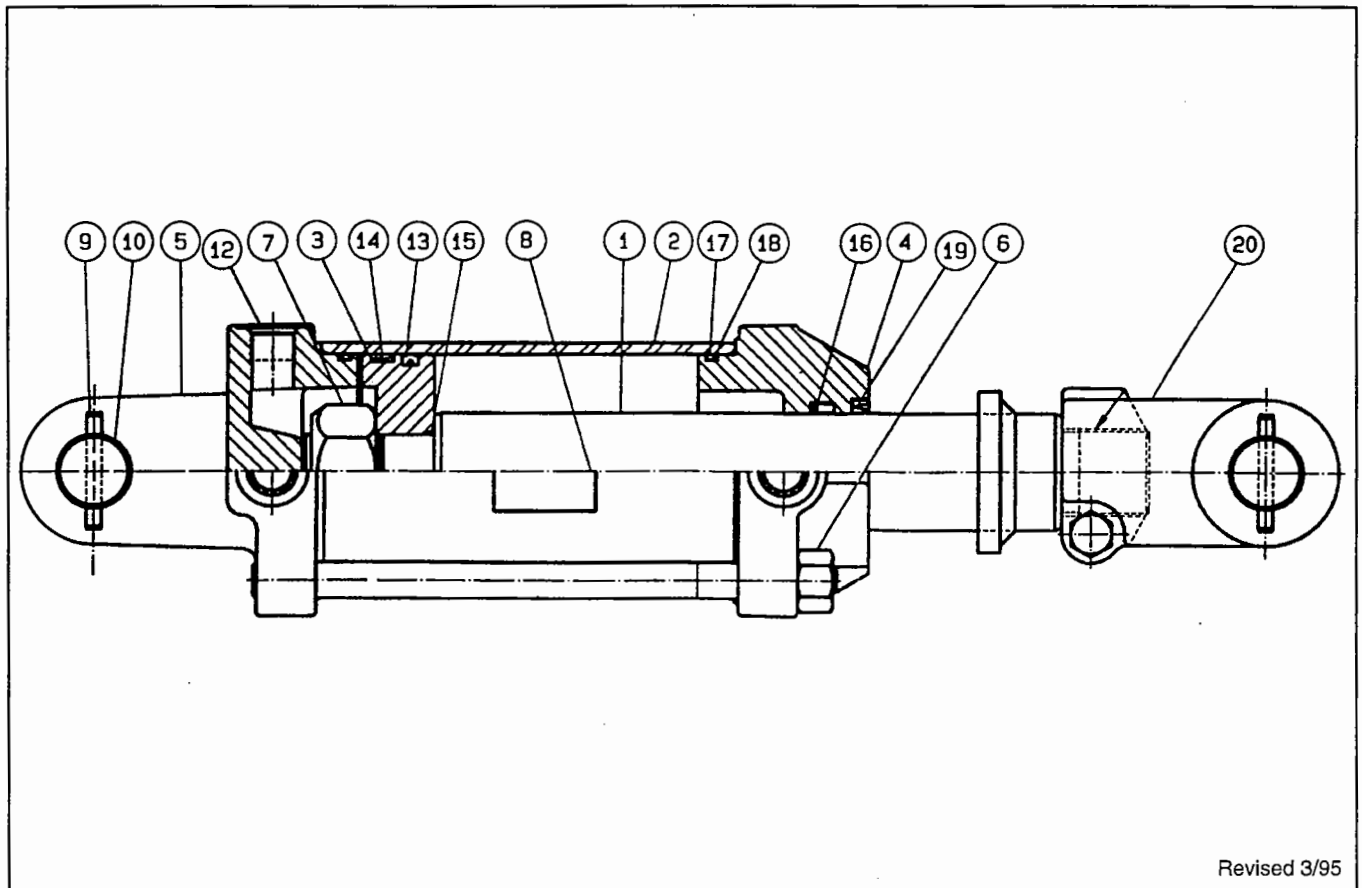

Revised 3/95

**FOR 21-171 4 X 16" Prince Hydraulic Cylinder Assembly**  
**Retracted - 31-1/2"    Extended - 47-1/2"    Stroke - 16"    Rod Diameter - 2"**

3/95

Item	Part Number	Part Description	Qty.
1	21-893	Piston Rod Assembly	1
2	21-282	Tube	1
3	21-879	Piston	1
4	21-894	Gland	1
5	21-738	Butt Casting	1
6	21-288	Tie Rod	4
7	21-286	1-1/4NC Lock Nut	1
8	74-113	Cylinder WARNING Decal	1
9	21-860	Roll Pin	4
10	21-859	Clevis Pin	2
11			
12	21-404	#8 SAE Plug	3
13	★ 21-649	Crown Seal	1
14	★ 21-880	Bearing Ring	1
15	★ 21-292	O-Ring	1
16	★ 21-352	U-Cup	1
17	★ 21-517	O-Ring	2
18	★ 21-656	Back-Up Washer	2
19	★ 21-721	Wiper	1
20	21-685	Clevis Assembly	1
	21-895	Seal Kit (★ Items Included In Kit)	-

# PRINCE HYDRAULIC CYLINDER ASSEMBLY

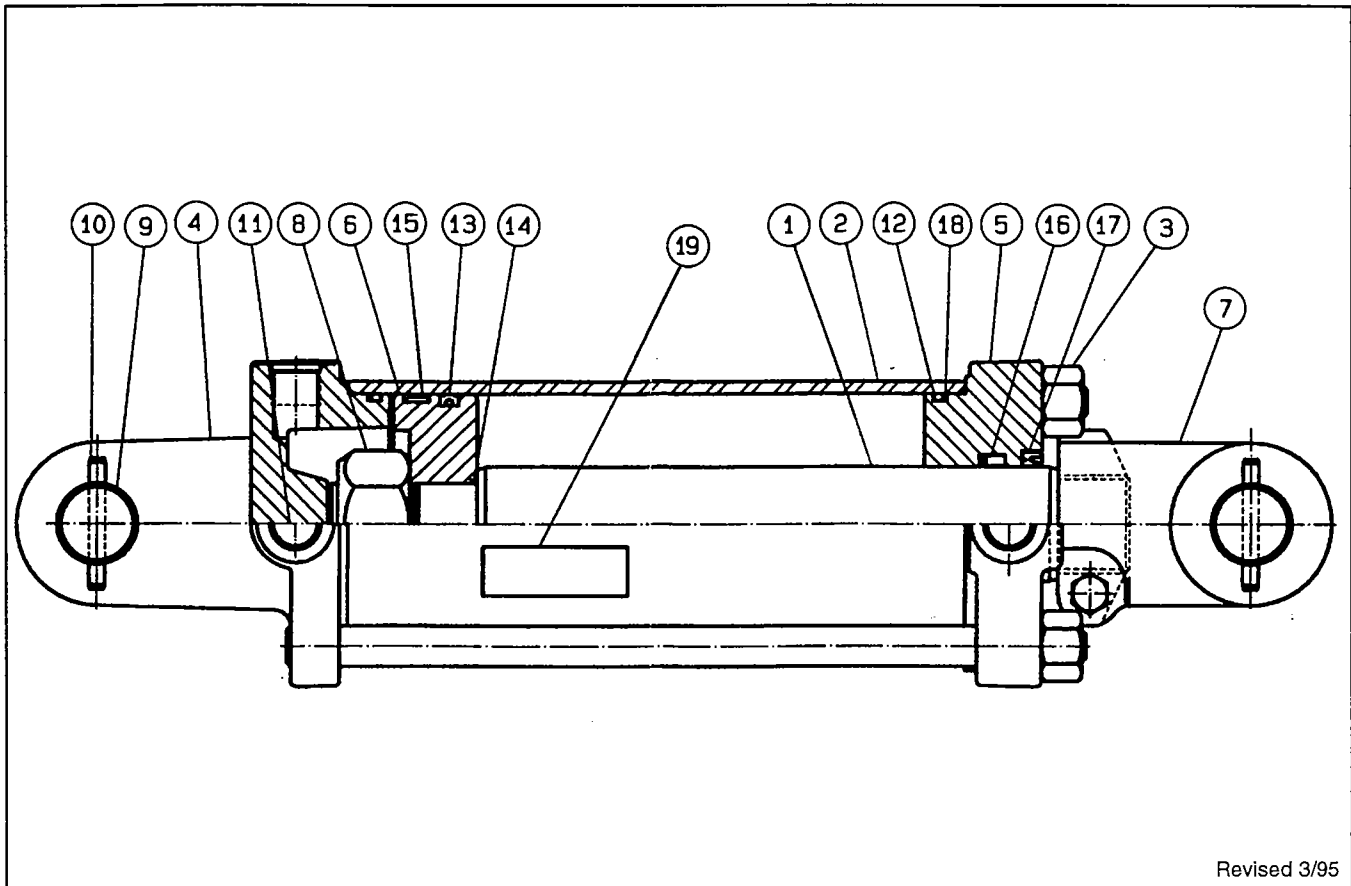

Revised 3/95

**FOR 21-172 4" X 32" Prince Hydraulic Cylinder Assembly**  
**Retracted - 42-3/4"    Extended - 74-3/4"    Stroke - 32"    Rod Diameter - 1-3/4"**

3/95

Item	Part Number	Part Description	Qty.
1	21-900	Piston Rod	1
2	21-266	Tube	1
3	21-901	Tie Rod	4
4	21-738	Butt	1
5	21-878	Gland	1
6	21-879	Piston	1
7	21-507	Clevis Assembly	1
8	21-286	Lock Nut	1
9	21-859	Clevis Pin	2
10	21-860	Roll Pin	4
11	21-404	#8 SAE Plug	3
12	☆ 21-517	O-Ring	2
13	☆ 21-649	Crown Seal	1
14	☆ 21-292	O-Ring	1
15	☆ 21-880	Bearing Ring	1
16	☆ 21-349	U-Cup	1
17	☆ 21-881	Wiper	1
18	☆ 21-656	Back-Up Washer	2
19	74-113	Cylinder WARNING Decal	1
	21-857	Seal Kit ( ☆ Items included in kit)	

# PRINCE HYDRAULIC CYLINDER ASSEMBLY

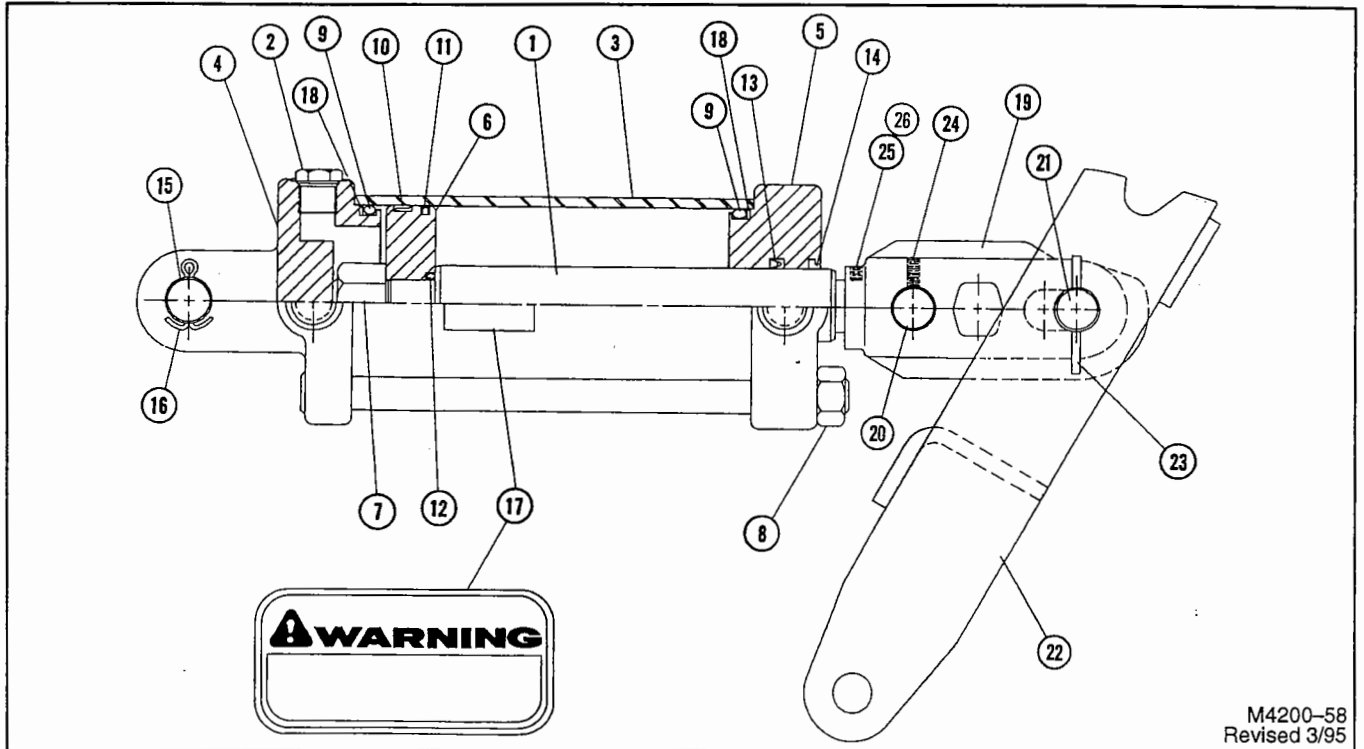

M4200-58  
Revised 3/95

## FOR 4241-80-0 4" X 24" Prince Hydraulic Wing Lift Cylinder Assembly

3/95

Item	Part Number	Part Description	Qty.
	21-174	4" x 24" Hydraulic Cylinder Assembly	1
1	21-896	Piston Rod	1
2	21-831	Plug	1
3	21-222	Tube	1
4	21-738	Butt	1
5	21-898	Gland	1
6	21-879	Piston	1
7	21-286	Lock Nut	1
8	★ 21-897	Tie Rod Assembly	4
9	★ 21-517	O-Ring	2
10	★ 21-880	Bearing Ring	1
11	★ 21-694	Crown Seal	1
12	★ 21-292	O-Ring	1
13	★ 21-352	U-Cup	1
14	21-721	Wiper	1
15	21-741	Clevis Pin	1
16	21-639	3/16" X 1-3/4" Cotter Pin	2
17	★ 74-113	Cylinder WARNING Decal	1
18	21-656	Back-Up Washer	2
19	4260-80-1	Rod End	1
20	4260-80-2	Pin	1
21	4260-80-3	Pin	1
22	4241-87-0	Lift Arm Weldment	1
23	60-618	3/8" x 3" Roll Pin	2
24	62-326	3/8NC x 1" Cup Point Set Screw	1
25	62-324	3/8NC x 3/8" Cup Point Set Screw	1
26	21-407	Nylon Bushing	1
	21-895	Seal Kit (★ Items included in kit)	

# DECALS

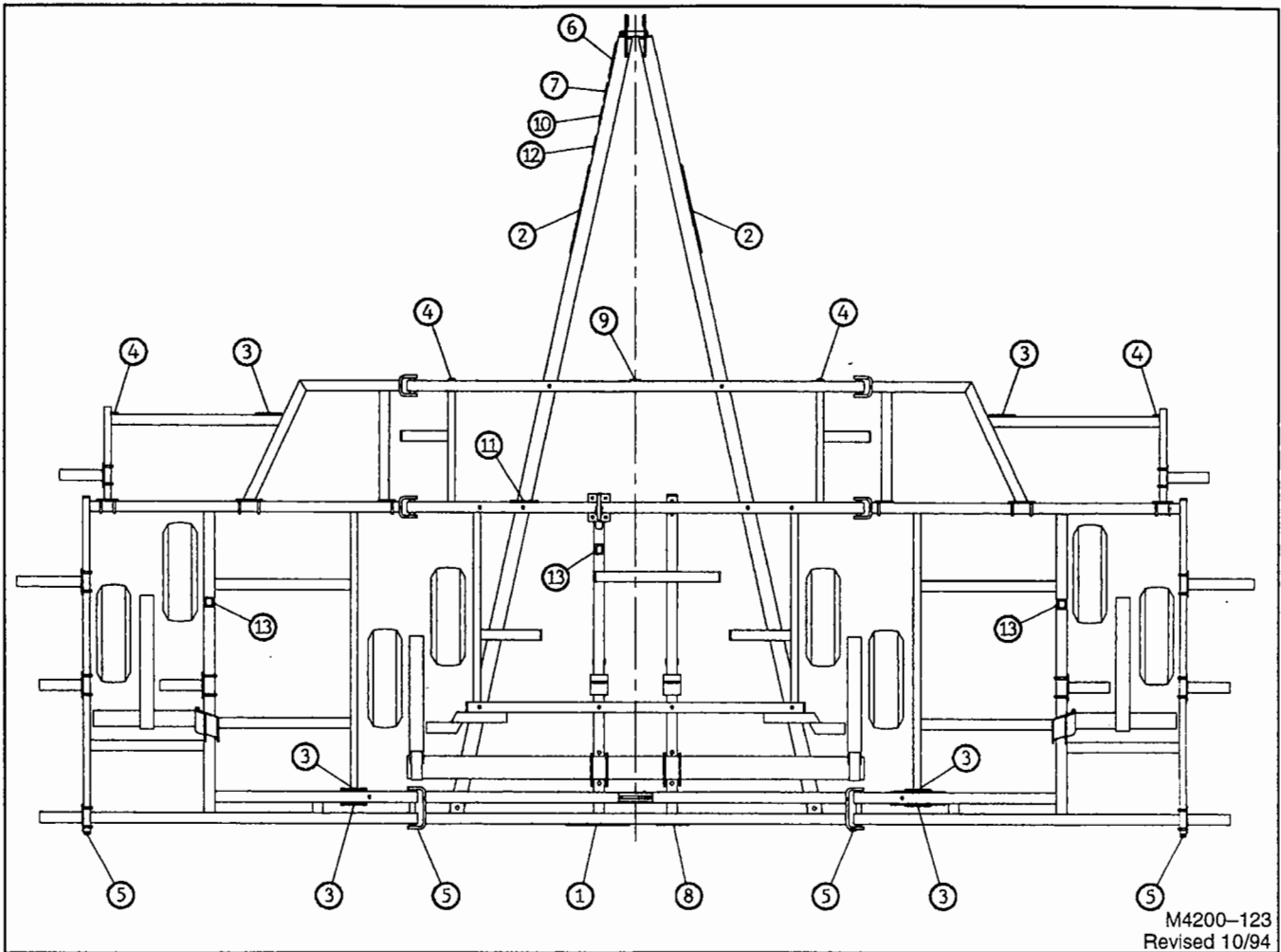

M4200-123  
Revised 10/94

FOR MODELS - ALL (Model 4226 Shown)

4/90

Item	Part Number	Part Description	Qty.
1	74-100	KRAUSE Decal (Small)	1
2	74-101	KRAUSE Decal (Large)	2
3	74-102	Stand Clear Of Wing Decal	6
4	74-107	Amber Reflector	4
5	74-108	Red Reflector	4
6	74-117	Implement Safety Decal	1
7	74-121	CAUTION Width / Height Decal	1
8	74-159	4200 SERIES Decal	1
9	74-162	K-Tine Decal	1
10	74-276	WARNING High Pressure Decal	1
11	74-312	Depth Adjustment Decal	1
12	74-158	Tongue Light Decal	1
13	74-355	WARNING Pin When Changing Sweeps Decal	3

# ASSEMBLY SECTION

THE FOLLOWING SECTION ILLUSTRATES A GENERAL METHOD FOR THE ASSEMBLY OF THIS SERIES KRAUSE TILLAGE TOOL. YOU MUST KNOW THE MODEL NUMBER OF THE UNIT BEING ASSEMBLED WHENEVER MAKING REFERENCE TO THIS SECTION. THE FOLLOWING PICTURES AND DRAWINGS WILL SHOW BOLTS, PINS, NUTS AND ETC., WITH THE DESCRIPTIVE SIZE AND LENGTHS IN THE ACCOMPANYING PARAGRAPH AND A PARTS LISTING REFERENCE PAGE NUMBER. IF ANY DIFFICULTY SHOULD BE ENCOUNTERED DURING THE ASSEMBLY, RECHECK THE ILLUSTRATIONS, ASSEMBLY STEPS AND PARTS LIST DRAWINGS.

# PROPER BOLT USE

DO NOT use these values if a different torque value or tightening procedure is given for a specific application. Torque values listed are for general use only. Check tightness of fasteners periodically.

Shear bolts are designed to fail under predetermined loads. Always replace shear bolts with identical grade.

Fasteners should be replaced with the same or higher grade. If higher grade fasteners are used, these should only be tightened to the strength of the original.

Tighten plastic insert or crimped steel-type lock nuts to approximately 110 percent of the dry torque shown in the chart, applied to the nut, not to the bolt head. Tighten toothed or serrated-type lock nuts to the full torque value.

*NOTE: "Lubricated" means coated with a lubricant such as engine oil, or fasteners with phosphate and oil coatings. "Dry" means plain or zinc plated without any lubrication.*

BOLT SIZE	BLACK OR PLATED BOLTS		OILED BOLTS	
	GRADE 2	GRADE 5	GRADE 2	GRADE 5
3/8"	20	33	16	26
7/16"	32	52	26	41
1/2"	50	80	39	63
5/8"	100	160	78	125
3/4"	175	280	140	225
7/8"	175	450	140	360
1"	270	675	210	540
1-1/8"	375	850	300	675
1-1/4"	530	1200	425	950
1-1/2"	930	1400	725	1250
<b>TIE ROD TIGHTENING TORQUE</b>				
1-1/2" Dia. Rods		1000 Ft. Lbs.		
1-3/4" Dia. Rods		1400 Ft. Lbs.		
2" Dia. Rods		1600 Ft. Lbs.		

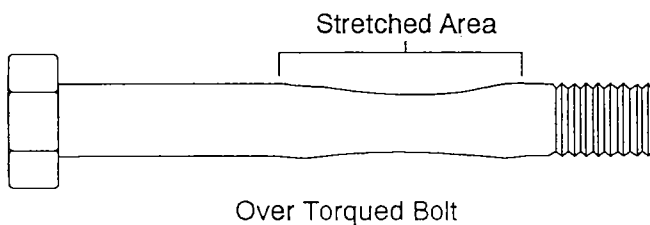

# Notes



A series of horizontal lines for writing, starting from the top margin and extending down to the middle of the page.



A series of horizontal lines for writing, starting from the middle of the page and extending down to the bottom margin.



A series of horizontal lines for writing, starting from the bottom margin and extending to the very bottom of the page.

**NOTE: MODEL 4241 SHOWN**

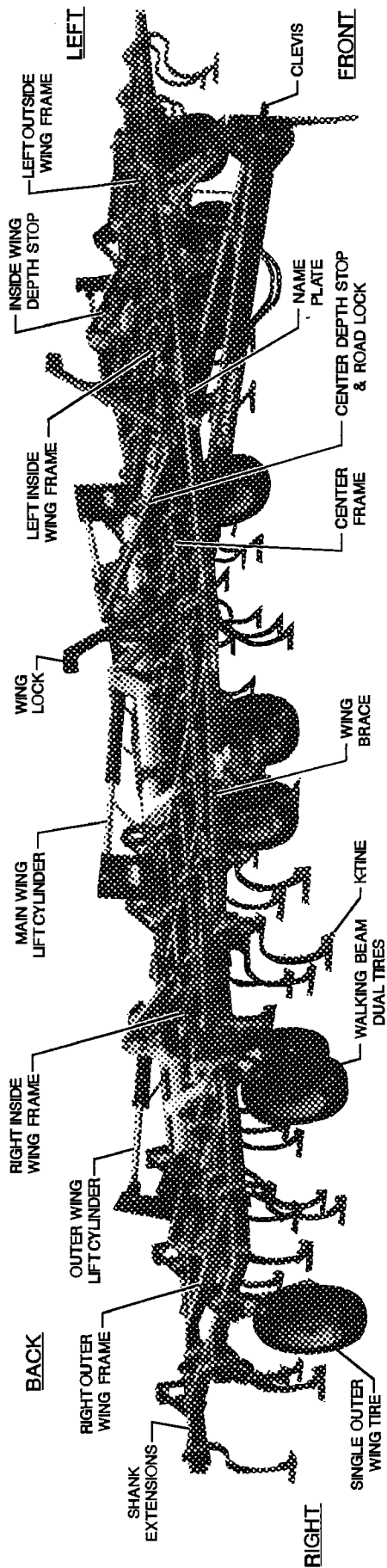

# ASSEMBLY

STUDY THE NAMES AND LOCATIONS OF THE PARTS AND FAMILIARIZE YOURSELF WITH THE FIELD CULTIVATOR BEFORE STARTING THE ASSEMBLY. READING THE STEP BY STEP INSTRUCTIONS THAT FOLLOW WILL BE HELPFUL.

## SAFETY



**READ ALL THE SAFETY NOTATIONS IN THE ASSEMBLY INSTRUCTIONS FOR YOUR OWN PROTECTION. ACCIDENTS CAN BE PREVENTED BY RECOGNIZING THE CAUSE OF AN ACCIDENT BEFORE IT CAN HAPPEN.**

## ASSEMBLY

Select an area for the assembly that will be large enough to accommodate the completed field cultivator. The surface of the work area should be as level as possible. Use the proper hand tools to insure proper bolt tightness. Refer to the page titled "Proper Bolt Use" for the recommended torque values of different size bolts.

## PART LOCATIONS

**FRONT** – The front of the frame can be determined by the location of the name plate that has been attached to the front frame member.

**RIGHT** and **LEFT** sides can be established by standing behind the frame looking toward the front, or the direction of travel.

**TOP** – To be sure the frame is right side up, position the frame with the wing lift hydraulic cylinder lug on top.

## ASSEMBLY STEPS

Shown here is one method of assembly that can be accomplished with a small crew of assemblers. Each step of assembly is accompanied with a picture or illustration with part names and bolt sizes listed.



**Warning:** Always attach chains securely. If a chain would break, the recoil action could cause the loose end to whip in any direction and injure any person nearby.

**Proof load rating of chain must equal or exceed 5 times the weight being lifted.**

THE HEAVIEST COMPONENT TO BE LIFTED INTO PLACE IS THE NARROW CENTER FRAME WHICH WEIGHS 985 LBS.

## MODEL NUMBERS

Know the model number of the field cultivator being assembled. Use the model number whenever referring to the assembly, parts listing pages or placement drawings. The number is stamped on the NAME PLATE located on the front frame member.



# I. CENTER FRAME, ROCKER, ROAD LOCK & WING LOCK ASSEMBLY (FOR MODELS 4218 & 4223)

1. Position frame on stands approximately 30" high with wing lift hydraulic cylinder lug on top and tongue beams underneath.
  - a. Fasten tongue jack to the left tongue member.

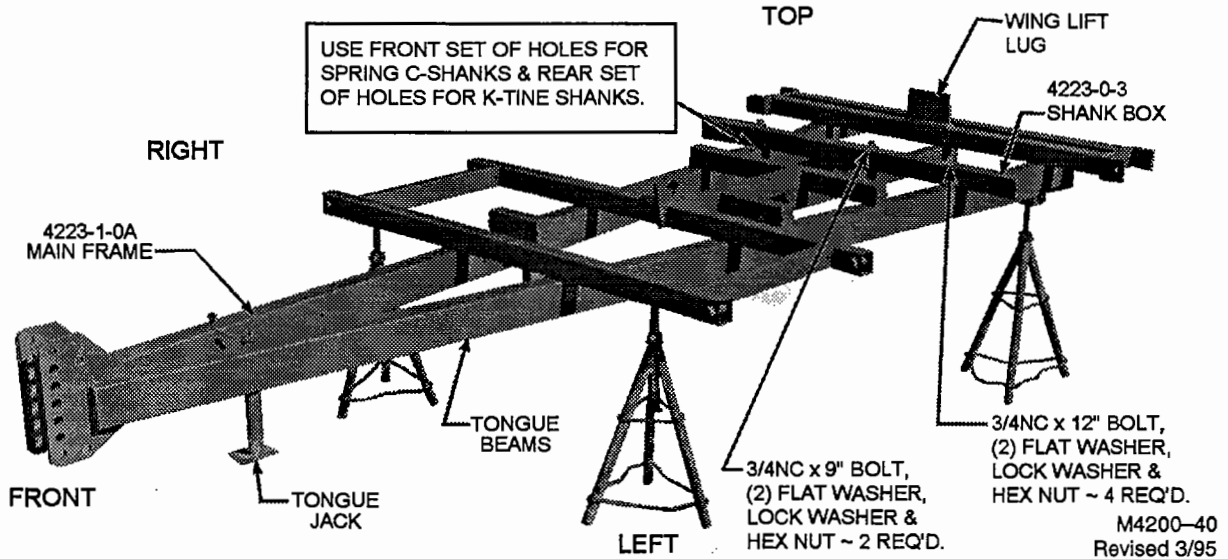

- b. Attach the Shank Box (4423-0-3) to the center frame. Use the REAR set of holes for K-Tines and the FRONT set of holes for Spring C-Shanks.

## 2. HITCH PLATES

- a. The hitch plates have been fastened together at the factory with a 1NC x 7-1/2" Bolt, Spacer (2330-0-5) 1" Lock Washer and Hex Nut.
- b. Assemble the HITCH CLEVIS with SPACER (1520-0-15) inside, with 1-1/4NC x 8" MACHINE BOLT. Before assembling the 1-1/4NC SELF LOCKING NUT, slide on BUSHING (1901-0-21), CLEVIS SPRING (76-119) and 1-1/4" FLAT WASHER.
- c. Special Washers (64-154) are provided with the 2" CRAWLER CLEVIS (1330-54-0) to take up the space between the clevis and the hitch plates.

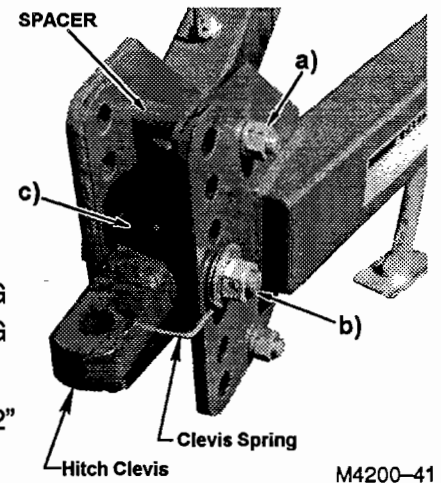

## 3. Six cast HALF CLAMPS (2145-0-16) will be needed to assemble the center rocker.

- a. Screw in 1/8" STD. Zerks in upper threaded holes.
- b. Insert T-2X Caplugs into lower side holes.
- c. Smear grease on bearing surface.

## 4. CENTER ROCKER CLAMPS

- a. Assemble rocker clamp castings together with 3/4NC x 2-1/2" GRADE 5 bolts, Lock Washers and Hex Nuts.
- b. Fasten the center rocker clamps to the frame with 1NC x 6-1/2" Bolts.

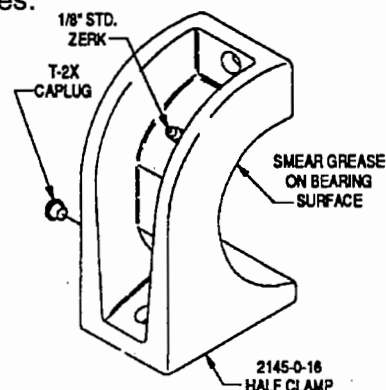

- c. Fasten the outer rocker clamps with 1NC x 8-1/2" Bolts.

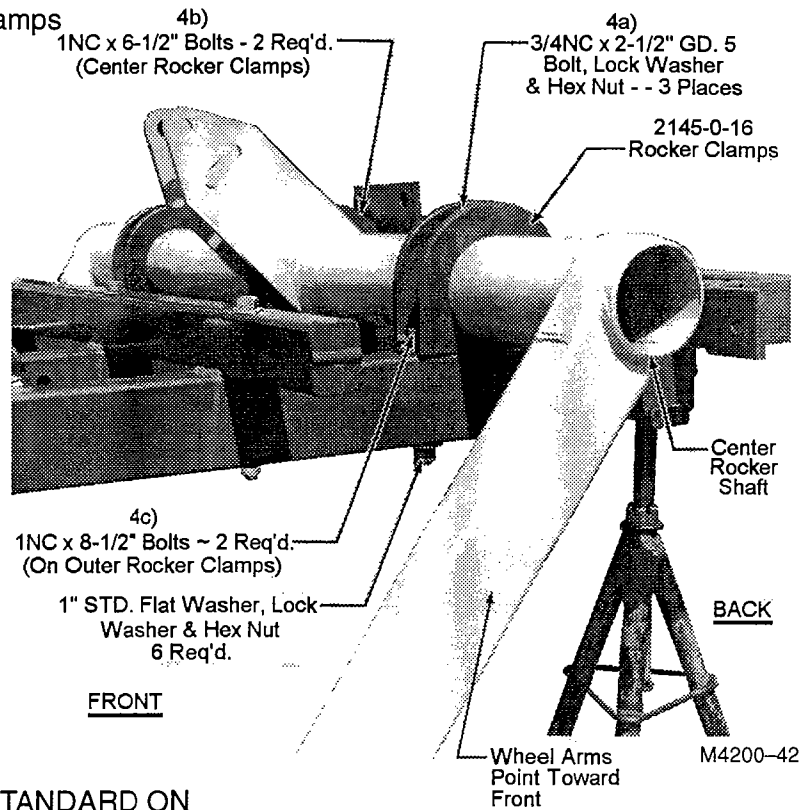

5. SINGLE HUB ASSEMBLY (STANDARD ON MODELS 4218 & 4223 CENTER & WINGS)

- a. There are two different single wheel hub positions depending on the type of shank used. (See accompanying illustration)

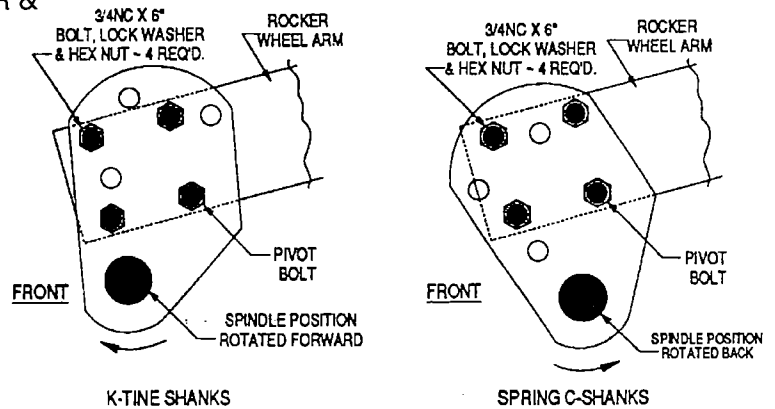

6. WALKING BEAM DUAL HUB ASSEMBLY (OPTIONAL ON 4218 & 4223 CENTER & ROCKER)

- a. Locate the walking beam hub assembly so that the grease zerk is on the top side and the front hub is toward the center of the cultivator.
- b. Loosen the clamp bolt so that the side plates can slide onto the wheel arm.
- c. Fasten the walking beam to the wheel arm with FIVE 3/4NC x 6" Bolts, Lock Washers and Hex Nuts.
- d. Tighten all SIX 3/4NC x 6" Bolts. NOTE: See page A16 for Optional Wing Walking Beam Assembly.

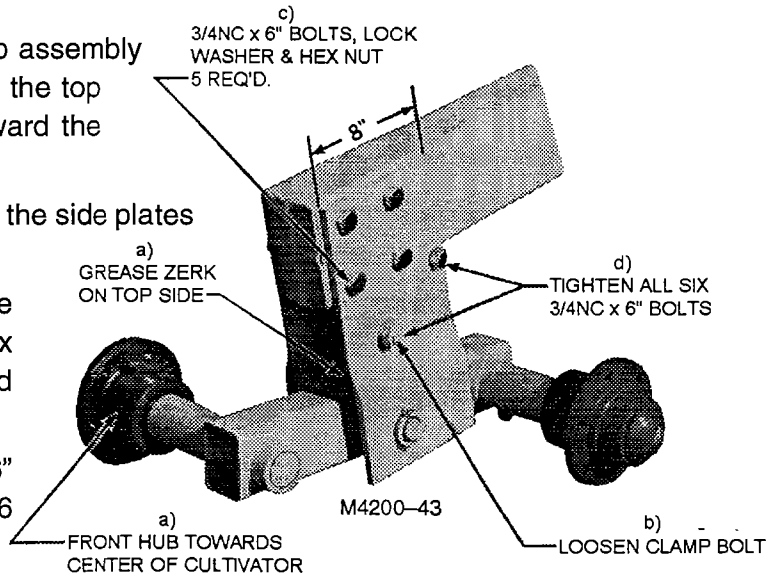

7. WHEELS & TIRES

- a. Remove the WHEEL BOLTS from the hubs and attach the WHEEL & TIRE ASSEMBLIES to the hubs.
- b. Torque all wheel bolts from 90 to 95 Foot Pounds.  
 Note: See the placement pages at the back of this manual for correct tire size for center and wing locations.

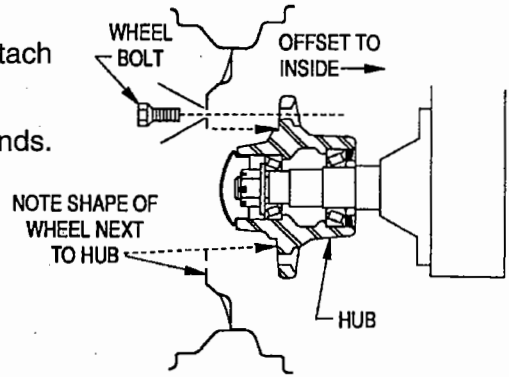

8. CENTER CYLINDER LUG & ROAD LOCK ASSEMBLY (MODELS 4218 & 4223)

- a. Fasten the STOP WELDMENT (4223-29-0) and the CYLINDER LUG (4226-29-0) with a 1NC x 5" Bolt and a 1" x 5" Clevis Pin.

NOTE: The Stop Weldment (4223-29-0) is assembled in the front set of holes for single wheels and in the back set of holes for walking beam duals wheels.

- b. Assemble the back end of the DEPTH STOP WELDMENT (4226-33-0) to the center rocker cylinder lug with a PIN (4226-0-5), a 1/4" x 2" Roll Pin, and a 3/16" x 2" Cotter Pin.

NOTE: The front holes is for single wheels and the back hole is for walking beam dual wheels.

- c. Insert the ROAD LOCK PIN (4226-0-1) through the DEPTH STOP WELDMENT and the front frame lug and retain it with a 1/4" x 2" Roll Pin and a #4 Hair Pin Cotter.

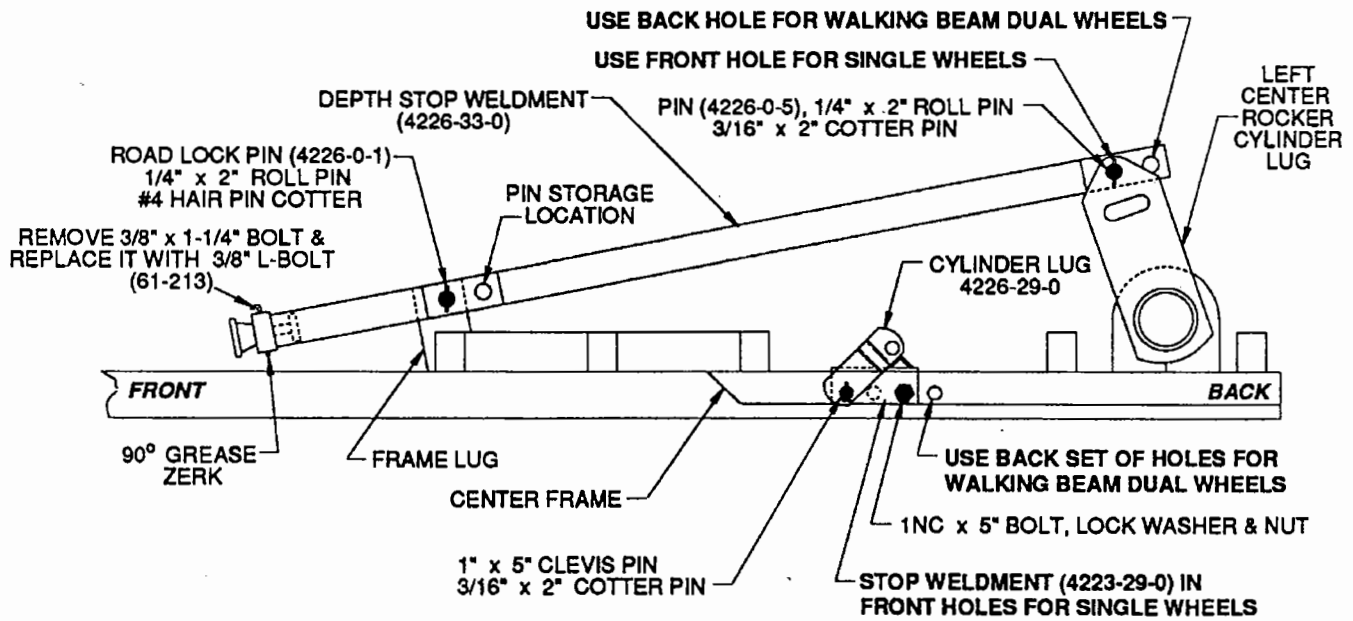

9. SELF-LEVELING TONGUE ASSEMBLY ACCESSORY #4223-50-0

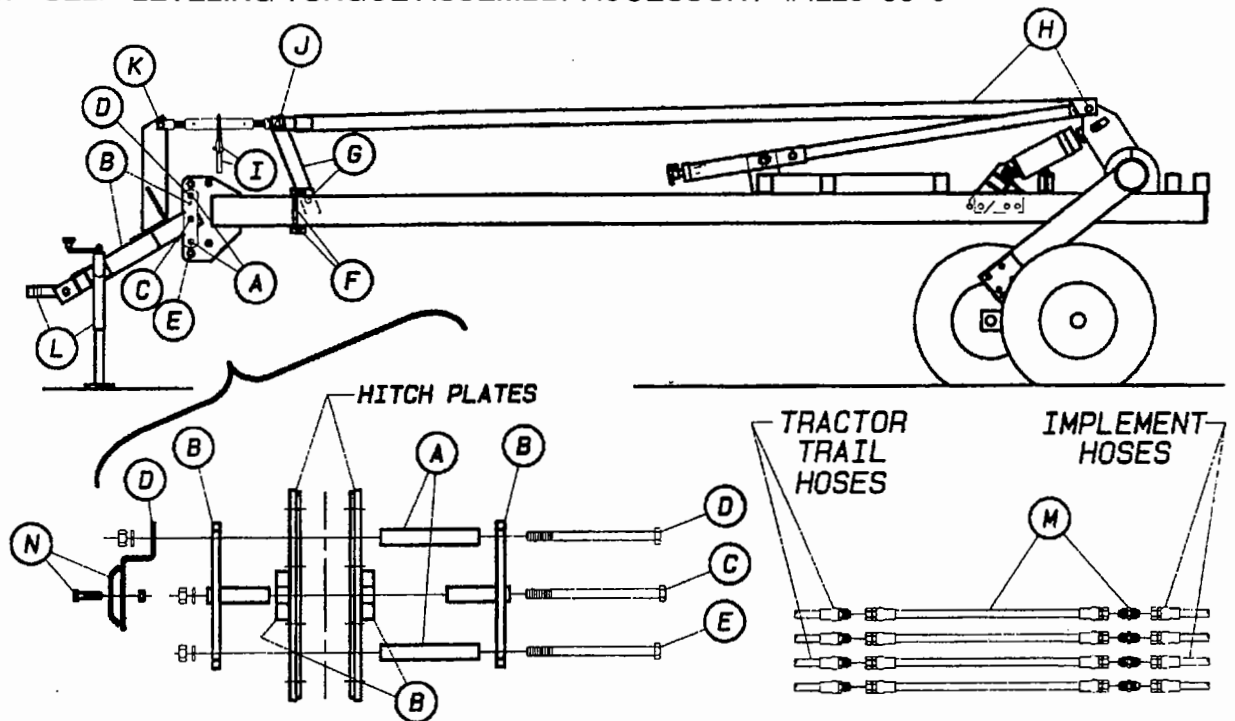

FRONT VIEW OF LEVELING TONGUE ASSEMBLY

M4200-60

- a. Slide 1-1/4" O.D. x 8-1/16" long SLEEVES (4226-0-7) into holes 2 and 6 of the front hitch plates.
- b. Attach the LEVELING TONGUE WELDMENT (4226-41-0) to the front hitch plate center holes with (2) PIVOT PLATE WELDMENTS (4226-44-0).
- c. Use a 3/4NC x 11" GD. 5 Machine Bolt, Lock Washer and Nut to clamp the PIVOT PLATES in place.
- d. Use a 3/4NC x 10-1/2" Machine Bolt, HOSE BRACKET (4223-53-1), Lock Washer and Nut to clamp the top together.
- e. Clamp the lower end with a 3/4NC x 10-1/2" GD. 5 Bolt also.
- f. Use (2) 3/4" DIA. U-Bolts (61-120) to fasten the LINK MOUNTING WELDMENT (4226-49-1) and then fasten it to the LINK MOUNTING WELDMENT (4223-47-0) between the Tongue Beams as shown.
- g. Slide a 1-1/4" O.D. x 13/16" long SLEEVE (612-0-2) into the SUPPORT LINK (4226-49-1) and then fasten it to the LINK MOUNTING with a 3/4NC x 3" GD. 5 Bolt, Lock Washer and Nut.
- h. Attach the LEVELING LINK (4223-54-0) to the Center Rocker Lug with a 1-1/4" DIA. x 7-1/16" long PIN (4226-0-9) and (2) 1/4" DIA. x 2" ROLL PINS.
- i. Fasten the HANDLE (4000-50-2) to the RATCHET JACK (4000-48-) with a 1/4" x 1-3/4" COTTER PIN.
- j. Assemble the RATCHET JACK to the LEVELING LINKS with a 1" DIA. x 4" long PIN (4226-0-8) and (2) 3/16" DIA. x 1-1/2" COTTER PINS.
- k. Pin the front end of the Ratchet Jack with the pin provided.
- l. Assemble the HITCH CLEVIS and TONGUE JACK to the LEVELING TONGUE.
- m. Add (4) 1/2" x 20" HOSES (24-360) and (4) 3/4" JIC MALE COUPLERS (25-304) between the TRACTOR TRAIL HOSES and the IMPLEMENT HOSES.
- n. Fasten the HOSE CLAMP (2426-170-5) to the HOSE BRACKET with a 1/2NC X 2" Cap Screw and 1/2NC Self Locking Nut.

- After the ROAD LOCK PIN has been properly installed, all bolts have been tightened and the tongue jack is in place, the stands can be removed and the center should be "free standing".

FREE STANDING  
CENTER  
SECTION

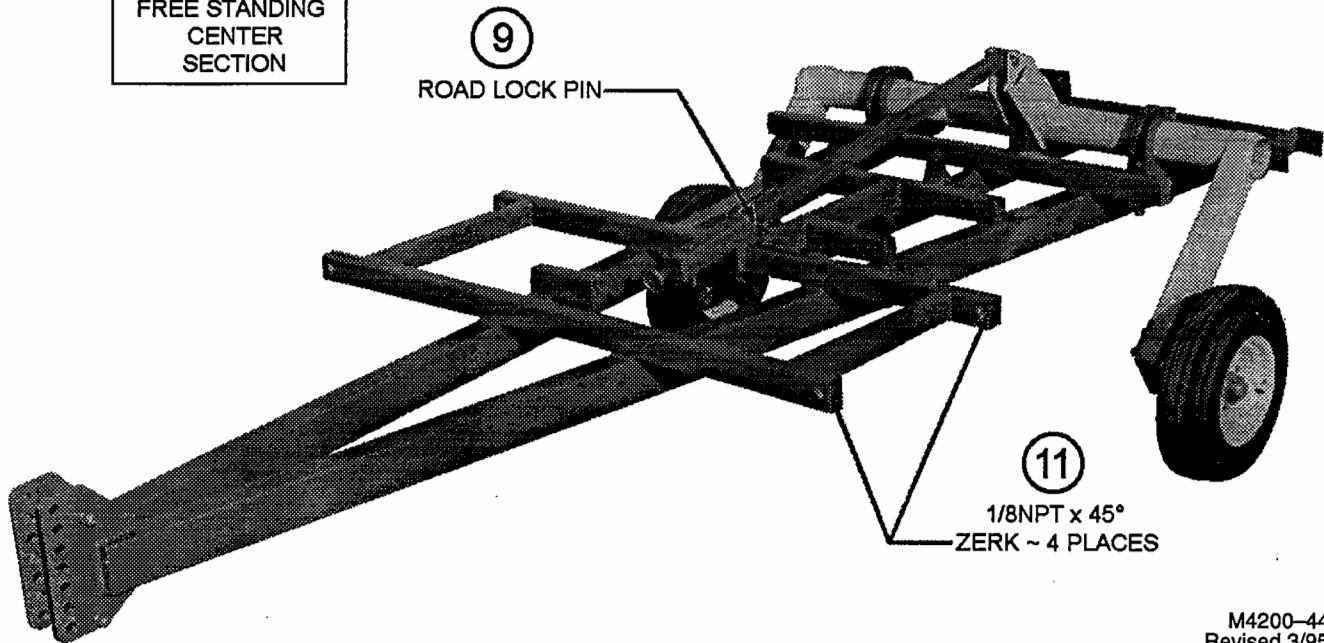

- Assemble the SMV LAMP BRACKET (74-144) to the mounting strap which is welded to the rear frame tube with a 7/16NC x 1" Carriage Bolt, Lock Washer and Hex Nut.

- Screw in FOUR 1/8NPT x 45° zerks at the front hinge locations.

- Position the Wing Lock so that it is centered between the hinge tubes. Fasten it in place with 3/4" U-Bolts (61-207), Lock Washers and Hex Nuts.

- Fasten the TWO WING LOCK PINS (1505-0-5) in the storage holes with #3 Hair Pin Cotter.

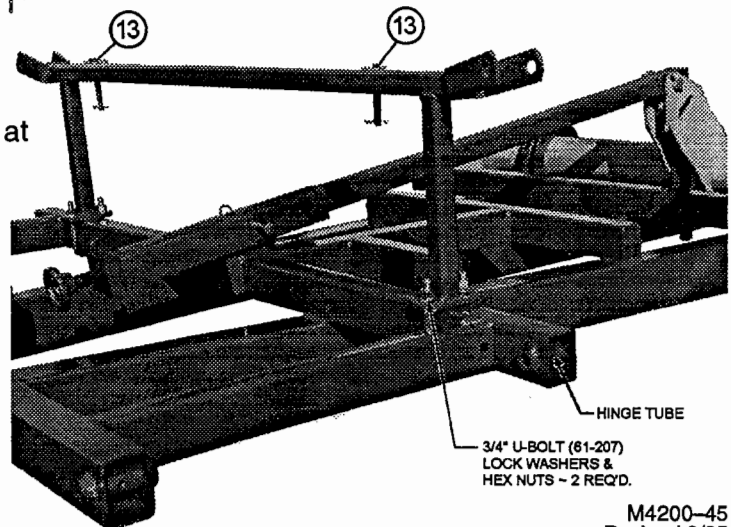

## II. CENTER FRAME, TONGUE, ROCKER, ROAD LOCK & WING LOCK (FOR MODELS 4226, 4231, 4237, 4241)

- Position front frame on stands approximately 30" high with the name plate to the front and the depth stop lug on top.
- Attach the left and right tongue members to the front and rear beams with 3/4NC x 12" Bolts, Flat Washers, Lock Washers and Hex Nuts.

NOTE: Bolt plates are on the bottom side of the tongue members.

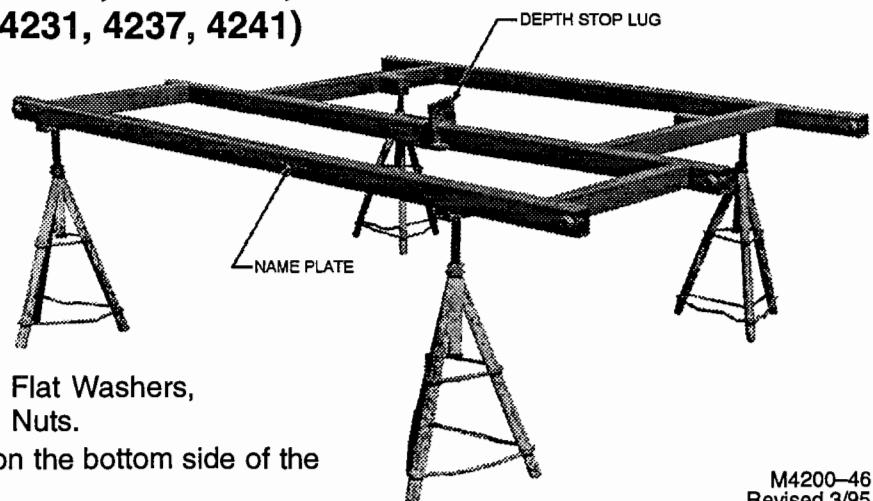

- Fasten the tongue members, frame, and wing locks together with 3/4NC x 12" Bolts, Lock Washers and Hex Nuts.
  - Fasten the outer end of each wing lock with a 3/4 U-Bolt (61-207), Lock Washer and Hex Nuts.
- NOTE: DO NOT TIGHTEN BOLT UNTIL STOP 9 HAS BEEN COMPLETED.

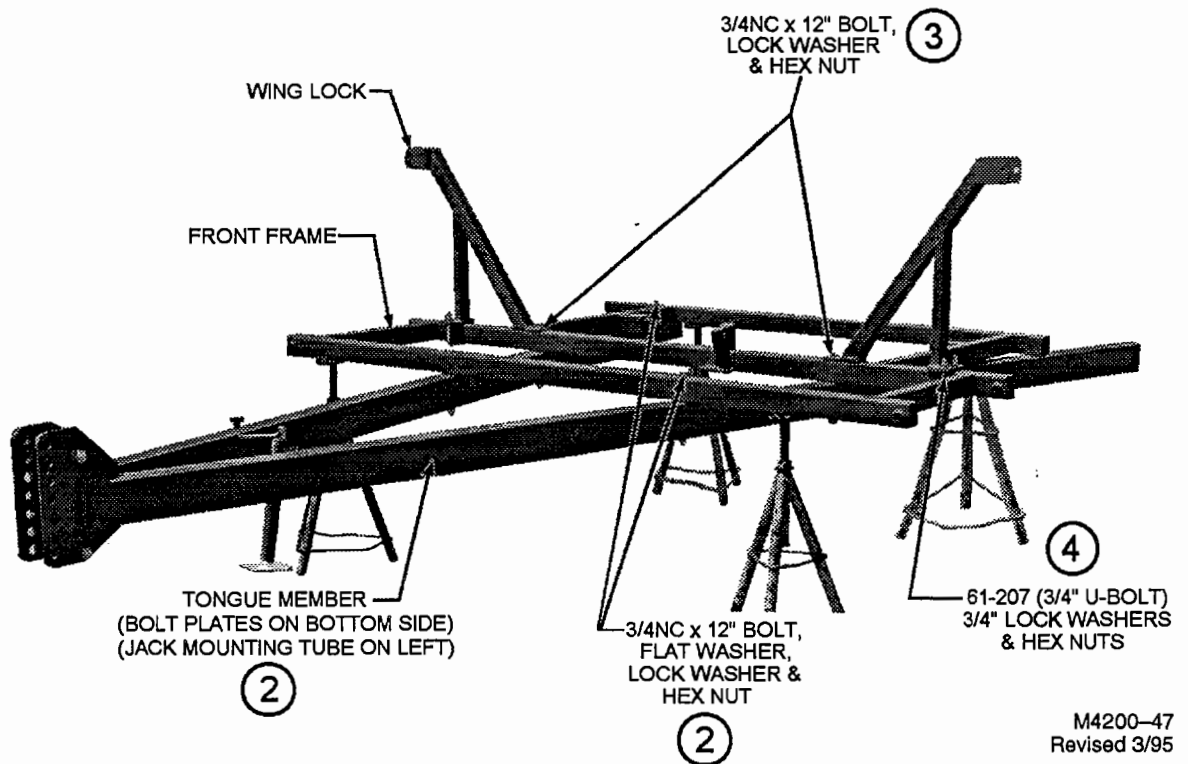

- Slide the rear frame in from the back until it is resting on top of the tongue members. Fasten the right side to the tongue with a 3/4NC x 12" Bolt, Flat washer, Lock Washer and Hex Nut.
- Fasten a LAMP BRACKET (4515-59-0) to the LEFT SIDE 3/4NC x 12" Bolt, Lock Washer and Hex Nut.

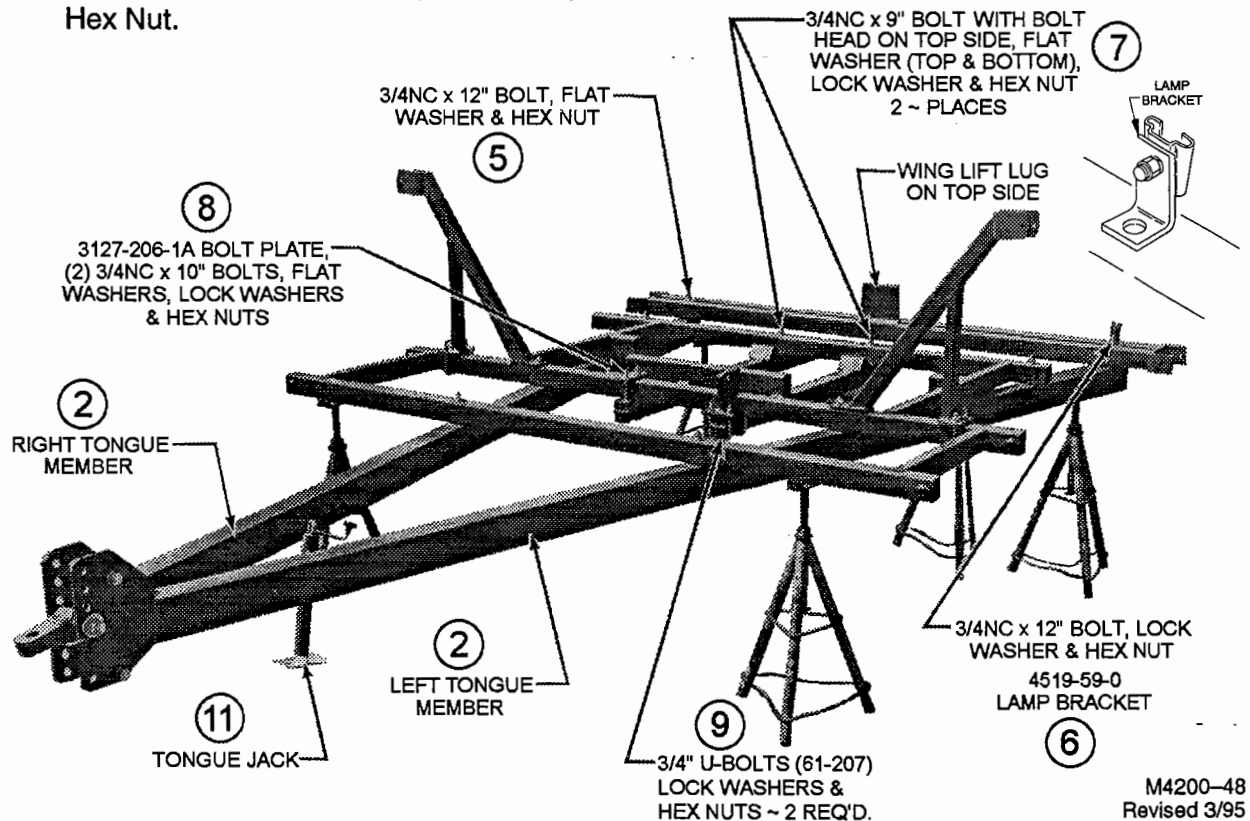

7. Assemble the rear frame to the front frame at TWO locations with a 3/4NC x 9" Bolts, TWO Flat Washers (top and bottom), Lock Washers and Hex Nuts.
8. Fasten the front end of the rear frame on the left side with TWO 3/4NC x 10" Bolts Flat Washers. Lock Washers and Hex Nuts.
9. Fasten the front end of the rear frame on the right side with TWO 3/4" U-Bolts (61-207), Lock Washers and Hex Nuts.

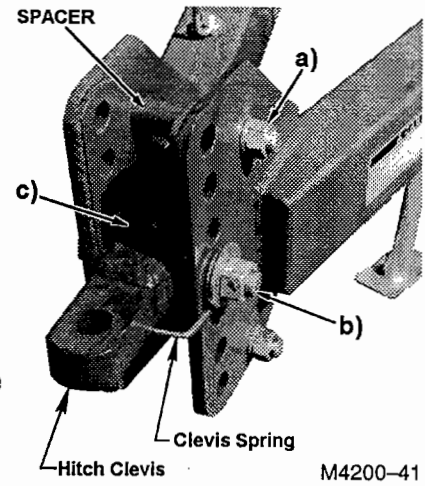

10. Tighten all frame bolts.
11. Fasten a TONGUE JACK (73-100) to the left tongue member.

12. HITCH PLATES

- a. Bolt Hitch Plates together using 1NC x 7-1/2" Bolts, Lock Washers, and Hex Nuts. Be sure SPACERS (2330-0-5) are in place.
- b. Assemble the HITCH CLEVIS with SPACER (1520-0-15) inside, with 1-1/4NC x 8" Machine Bolt. Before assembling 1-1/4NC Self Locking Nut, slide on BUSHING (1901-0-21), CLEVIS SPRING (76-119) and 1-1/4" Flat Washer.

13. Fasten each offset shank box to the back side of the front frame weldment as shown. NOTE: The shank box is offset to the back for K-Tines and to the front for Spring C-Shanks.

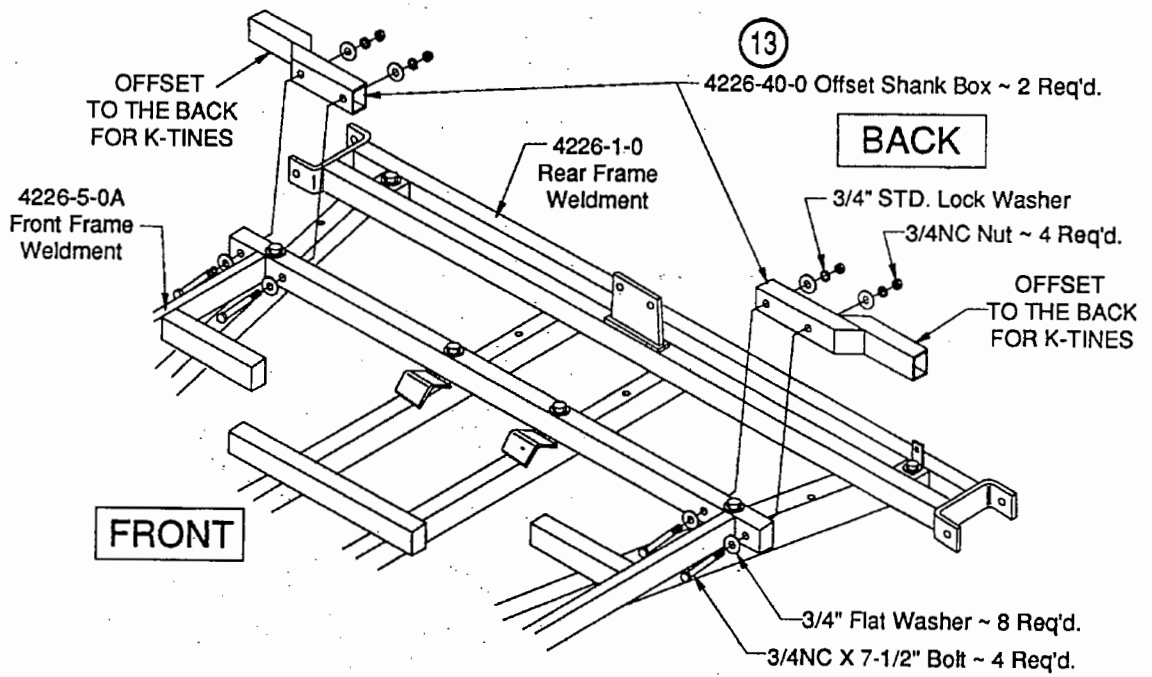

OFFSET SHANK BOX ASSEMBLY FOR K-TINES

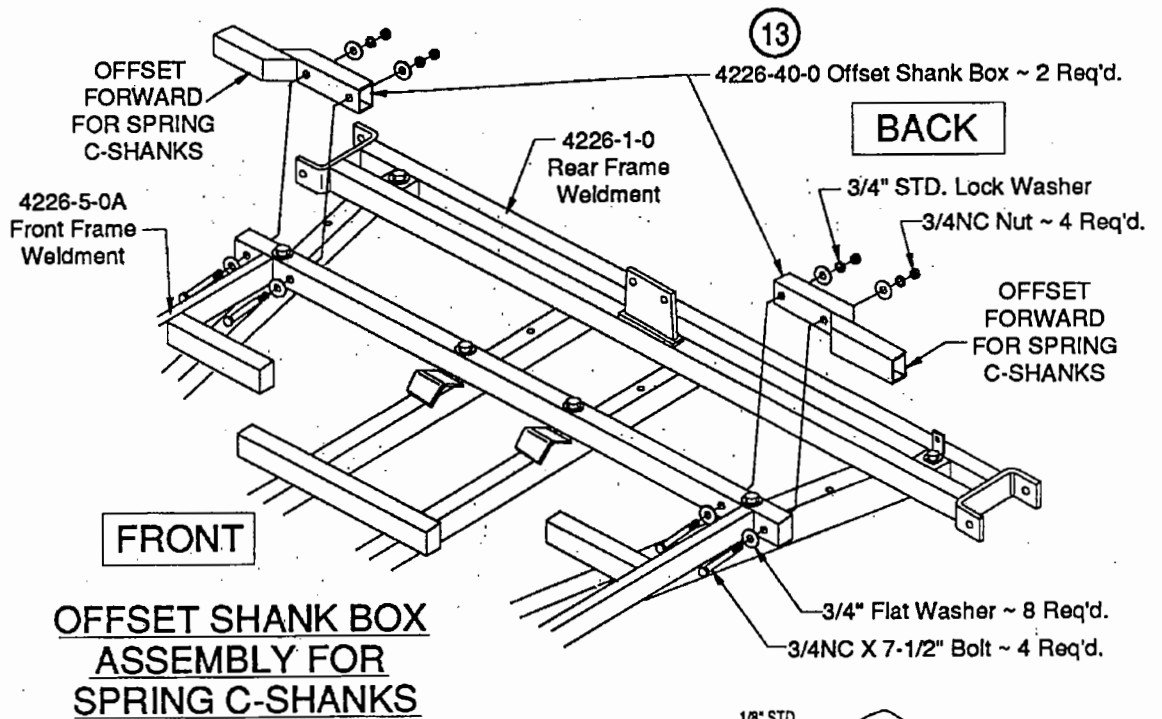

**OFFSET SHANK BOX  
ASSEMBLY FOR  
SPRING C-SHANKS**

14. EIGHT cast HALF CLAMPS (2145-0-16) will be needed to assemble the center rocker.
- Screw in 1/8" STD. Zerks in upper threaded holes.
  - Insert T-2X Caplugs into the lower side holes.
  - Smear grease on bearing surface.

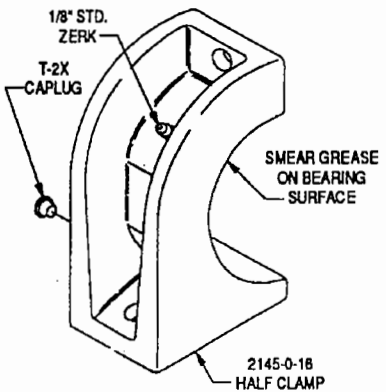

15. **ROCKER CLAMPS**
- Assemble rocker clamp castings together with 3/4NC x 2-1/2" GRADE 5 Bolts, Lock Washers and Hex Nuts.
  - Fasten the center rocker clamps to the frame with 1NC x 6-1/2" Bolts.
  - Fasten the outer rocker clamps with 1NC x 8-1/2" Bolts.

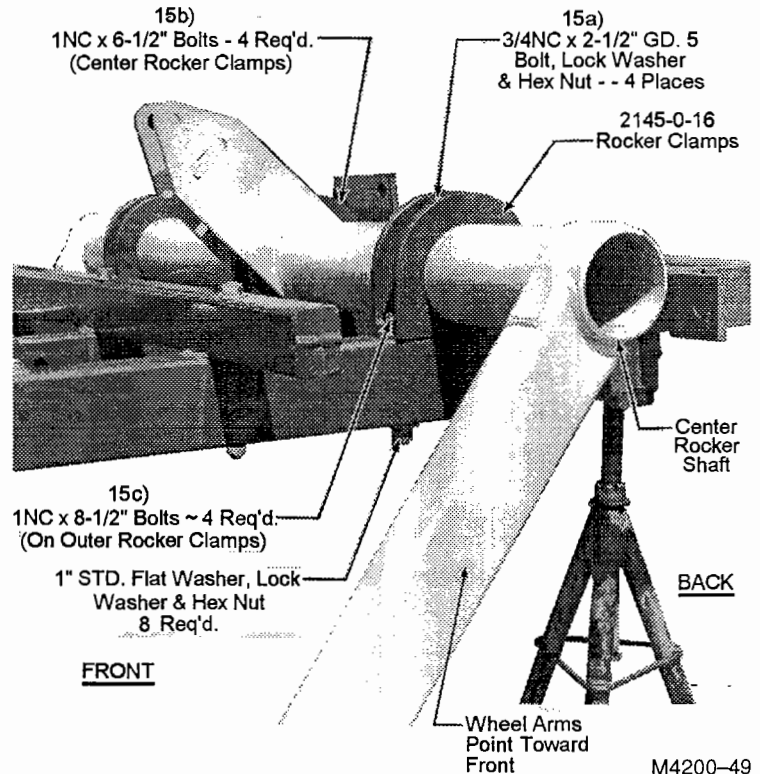

16. CENTER WALKING BEAM DUAL HUB ASSEMBLY (STANDARD ON MODELS 4226, 4231, 4237 & 4241 CENTER ROCKER)

- Locate the walking beam hub assembly so that the grease zerk is on the top side and the front hub is toward the center of the cultivator.
- Loosen the clamp bolt so that the side plates can slide onto the wheel arm.
- Fasten the walking beam to the wheel arm with FOUR 3/4NC x 6" Bolts, Lock Washer and Hex Nut.
- Tighten all FIVE 3/4NC x 6" Bolts.

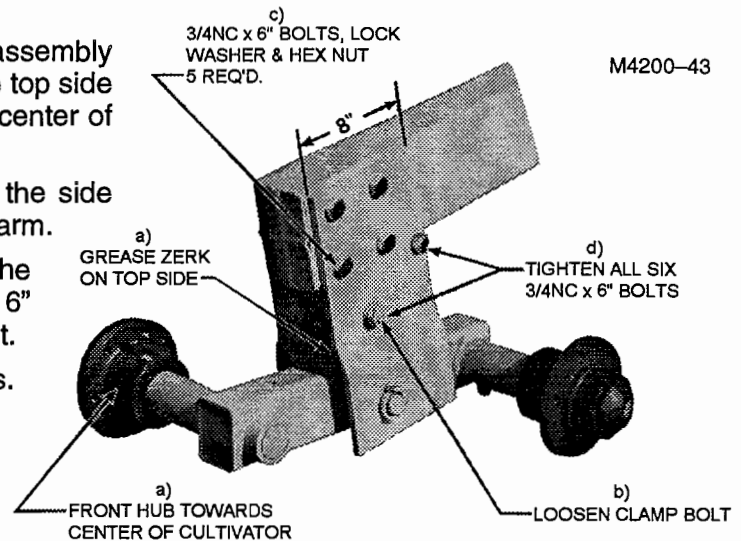
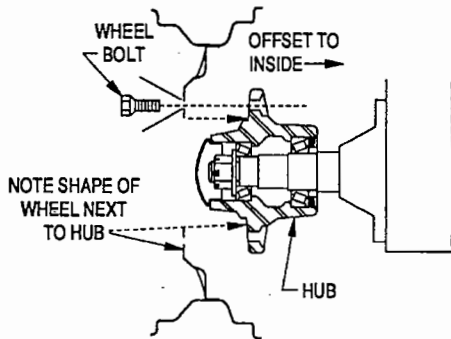

- Remove the WHEEL BOLTS from the hubs and attach the WHEEL & TIRE ASSEMBLIES to the hubs. TORQUE ALL WHEEL BOLTS FROM 90 TO 95 FOOT POUNDS.

NOTE: See placement pages at back of this book for correct tire size and wing wheels.

18. CYLINDER LUG & ROAD LOCK ASSEMBLY (MODELS 4226, 4231, 4237 & 4241)

- Fasten both CYLINDER LUGS (4226-29-0) to the frame with 1" x 5" Clevis Pins and 3/16" x 2" Cotter Pins.
- Assemble the back end of the DEPTH STOP WELDMENT (4226-33-0) to the left center rocker cylinder lug with a PIN USE BACK HOLE FOR WALKING BEAM DUAL WHEELS (4226-0-5), a 1/4" x 2" Roll Pin and a 3/16" x 2" Cotter Pin.

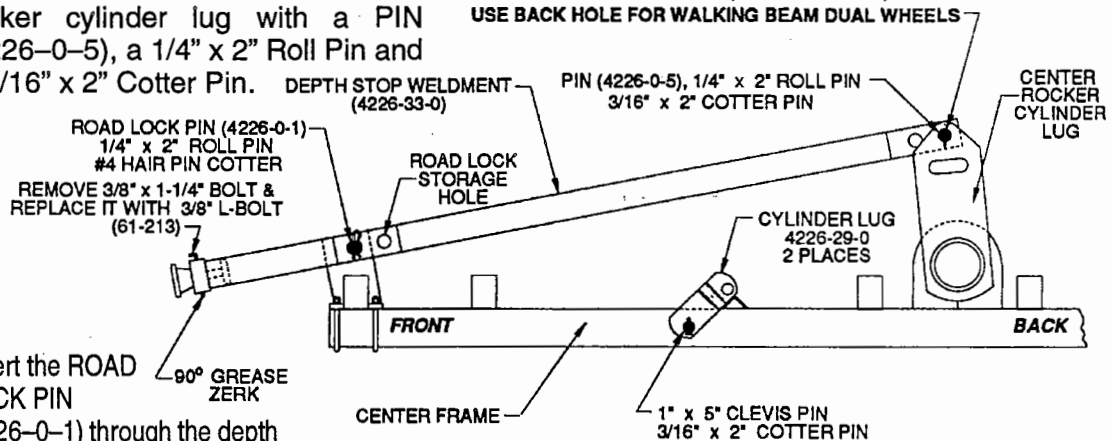

- Insert the ROAD LOCK PIN (4226-0-1) through the depth stop weldment and the front frame lug and retain it with a 1/4" x 2" Roll Pin and a #4 Hair Pin Cotter.

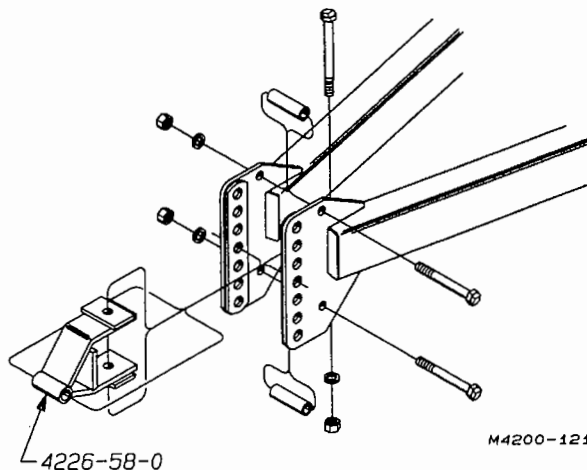

**SELF LEVELING TONGUE  
HITCH SUPPORT WELDMENT**

**IMPORTANT:**

ASSEMBLE #4226-58-0 HITCH SUPPORT WELDMENT IN BETWEEN HITCH PLATES BEFORE LEFT & RIGHT TONGUES ARE BOLTED TOGETHER.

M4200-121

19. SELF LEVELING TONGUE ASSEMBLY ACCESSORY #4226-50-0

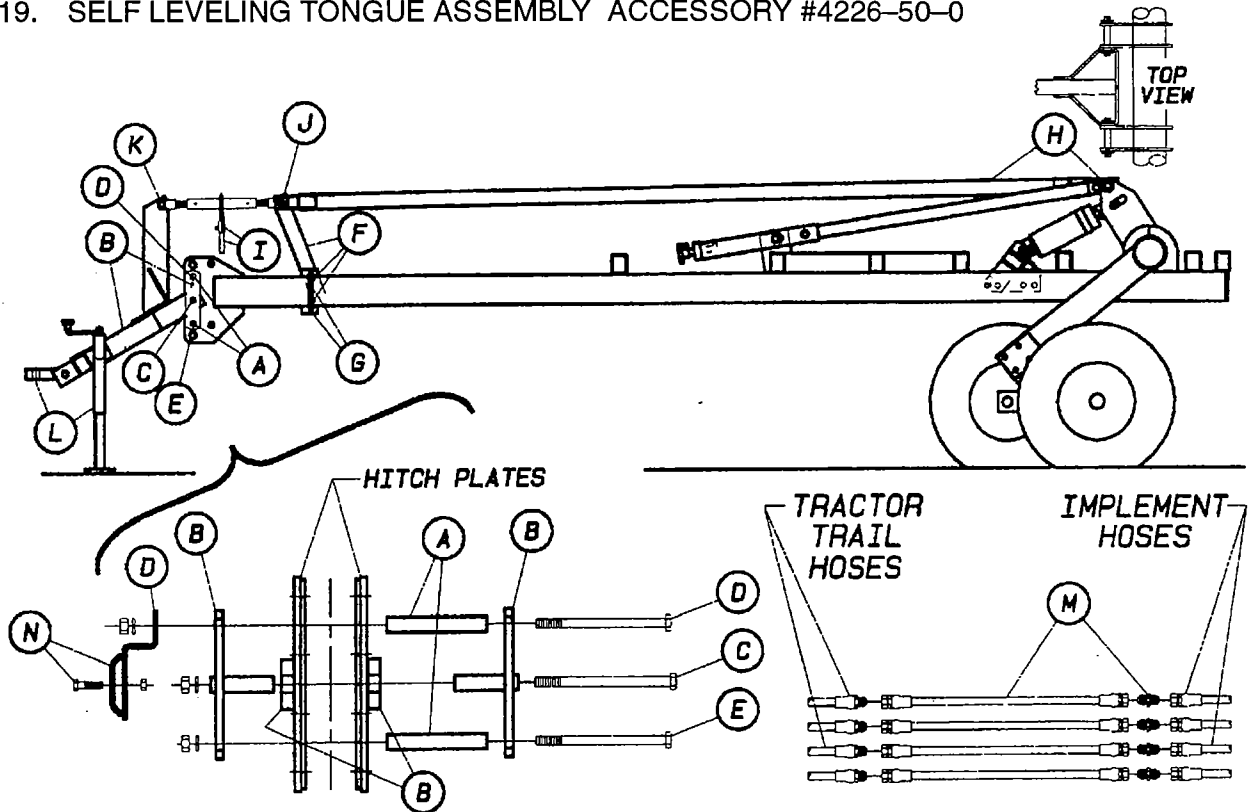

FRONT VIEW OF LEVELING TONGUE ASSEMBLY

M4200-61

- a. Slide 1-1/4" O.D. x 8-1/16" long SLEEVES (4226-0-7) into holes 2 and 6 of the front hitch plates.
- b. Attach the LEVELING TONGUE WELDMENT (4226-41-0) to the front hitch plate center holes with (2) PIVOT PLATE WELDMENTS (4226-44-0).
- c. Use a 3/4NC x 11" GD. 5 Machine Bolt, Lock Washer and Nut to clamp the PIVOT PLATES in place.
- d. Use a 3/4NC x 10-1/12" Machine Bolt, HOSE BRACKET (5334-64-2) Lock Washer and Nut to clamp the top together.
- e. Clamp the lower end with a 3/4NC x 10-1/2" GD.5 Bolt also.
- f. Clamp the SUPPORT LINK (4226-49-1) between the (2) LINK MOUNTS (4226-49-2) with (2) 1-1/4" DIA. x 13/16" long SLEEVES (612-0-2), (2) 3/4NC x 3" GD. 5 Cap Screws, Lock Washers and Hex Nuts.
- g. Use (2) 3/4" DIA. U-BOLTS (61-120) to fasten the LINK MOUNTING ASSEMBLY between the tongue beams as shown.
- h. Attach the LEVELING LINK (4226-46-0) to the Center Rocker Lugs with (2) 1-1/4" DIA. x 7-1/16" PINS (4226-0-9). (4) 1-1/2" SAE Flat Washers and (4) 1/4" DIA. 2" Roll Pins.
- i. Fasten the HANDLE (4000-50-2) to the RATCHET JACK (4000-48-0) with a 1/4" DIA. x 1-3/4" COTTER PIN.
- j. Assemble the RATCHET JACK to the LEVELING LINKS with a 1" DIA. x 4" long PIN (4226-0-8) and (2) 3/16" DIA. x 1-1/2" COTTER PINS.
- k. Pin the front end of the Ratchet Jack with the pin provided.
- l. Assemble HITCH CLEVIS and TONGUE JACK to the LEVELING TONGUE.
- m. Add (4) 1/2" x 20" HOSES (24-36) and (4) 3/4" JIC MALE COUPLERS (25-304) between the TRACTOR TRAIL HOSES and the IMPLEMENT HOSES.
- n. Fasten the HOSE CLAMP (2426-170-5) to the HOSE BRACKET with a 1/2NC x 2" Cap Screw and 1/2NC Self Locking Nut.

20. After the Road Lock Pin has been properly installed, all bolts have been tightened, and the tongue jack is in place, the stands can be removed and the center frame should be free standing.

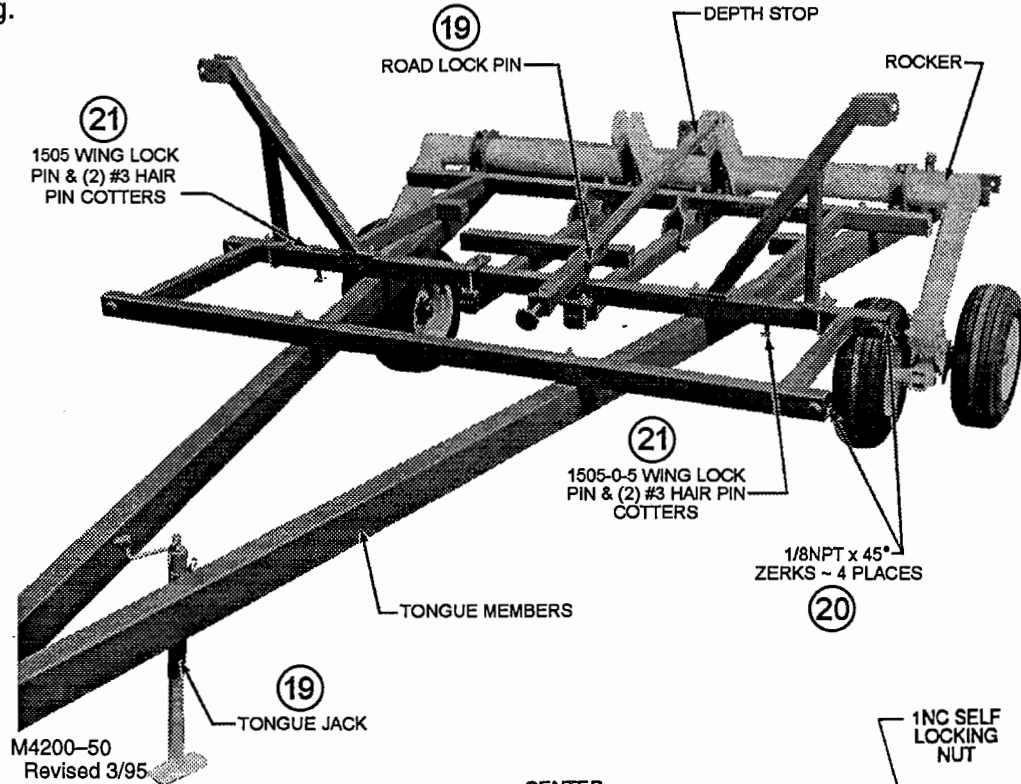

21. Screw in FOUR 1/8NPT x 45 degree zerks at the front hinge locations.
22. Assemble WING LOCK PINS (1505-0-5) into the storage holes below the wing locks and retain it with TWO #3 Hair Pin Cotter.

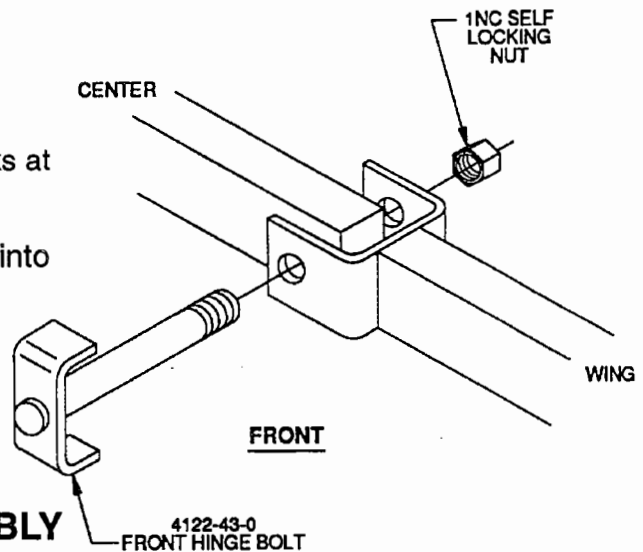

### III. WING FRAME & ROCKER ASSEMBLY

1. Attach the front wing hinge to the center frame with a HINGE BOLT (4122-43-0) and a 1NC Self Locking Nut.
2. Use a HINGE BOLT (4218-42-0) SPECIAL WASHER (64-141), and a 1NC Self Locking Nut to fasten the rear wing hinge to the center frame.
3. Screw a 1/8NPT x 90 degree zerk into the rear hinge as shown.

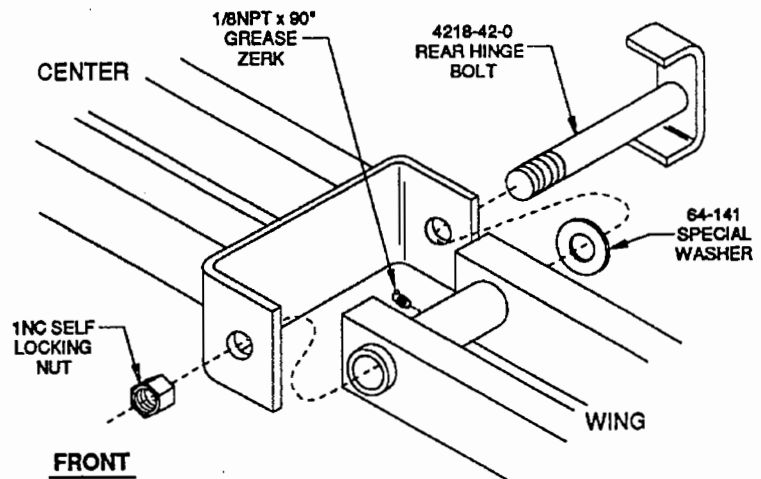

4. Support the outer end of the wing with a frame stand. Make sure the stand is in a position that will not interfere with following assembly steps.

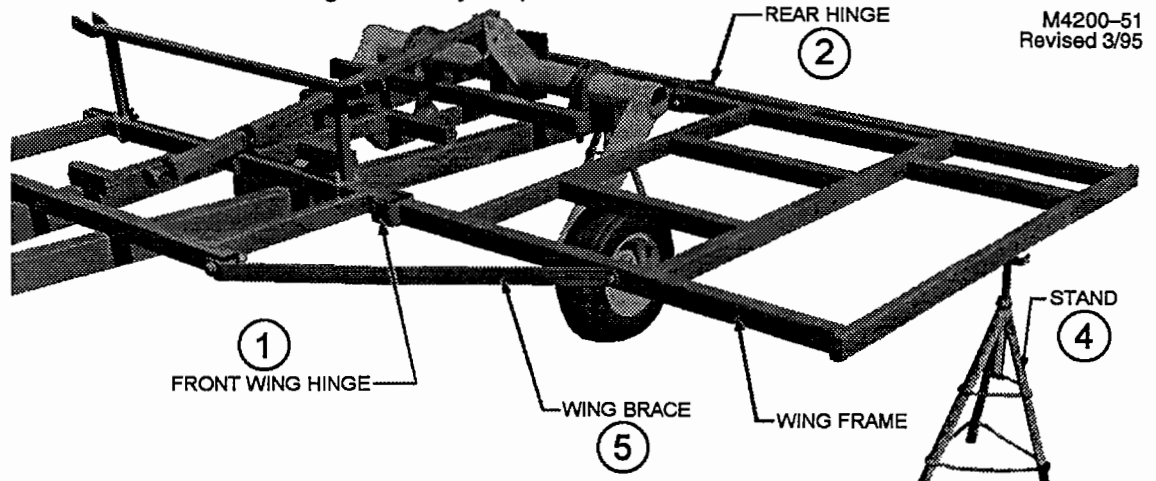

5. WING BRACE (MODELS 4218, 4223, 4226, 4231, 4237)

Fasten the wing brace from the front center frame hinge to the wing frame as shown.

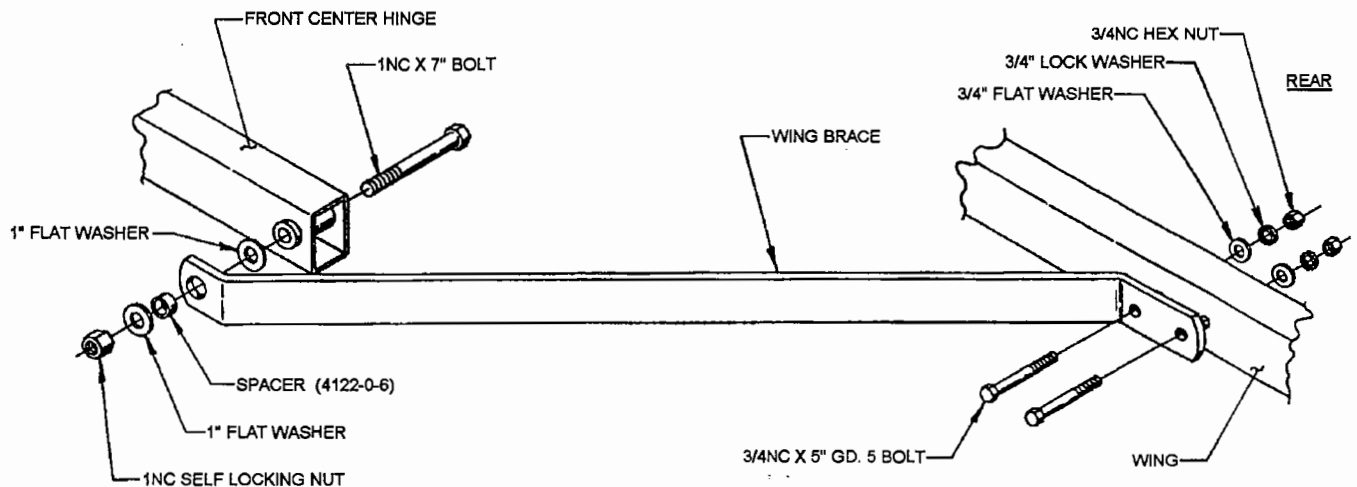

M4200-120

6. Insert **ROCKER BEARINGS** (4260-0-7) into both ends of the wing rocker. Lower the rocker into the wing frame and fasten the outer end with 3/4NC x 4" bolts. Fasten the inside end with 3/4NC x 5" bolts. Screw a 1/8NPT STD. Zerk into the rocker bearing castings.

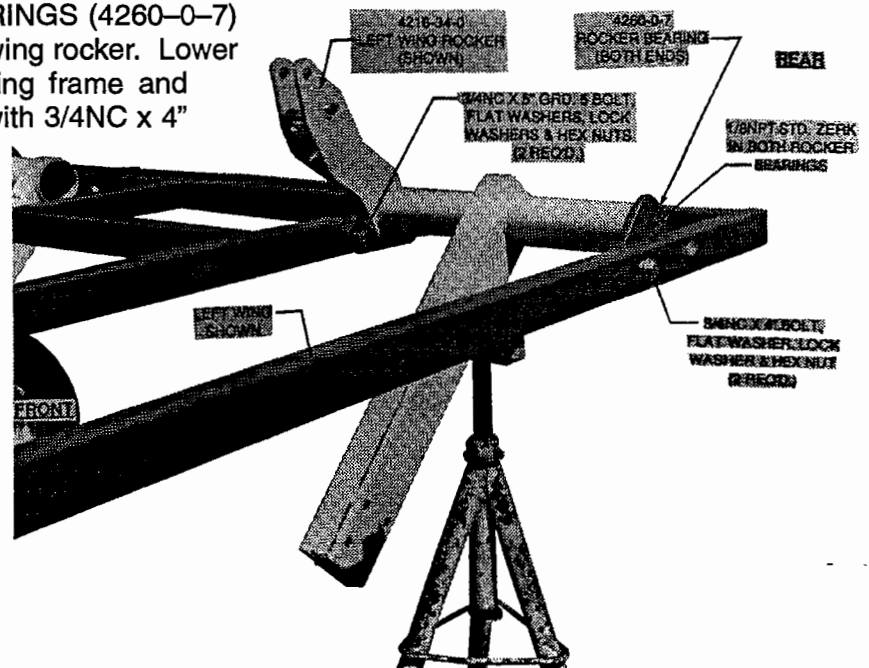

## 7. SINGLE HUB ASSEMBLY (STANDARD ON 4218, 4223 & 4226 WINGS)

There are TWO different single wheel hub positions depending on the type of shank used.

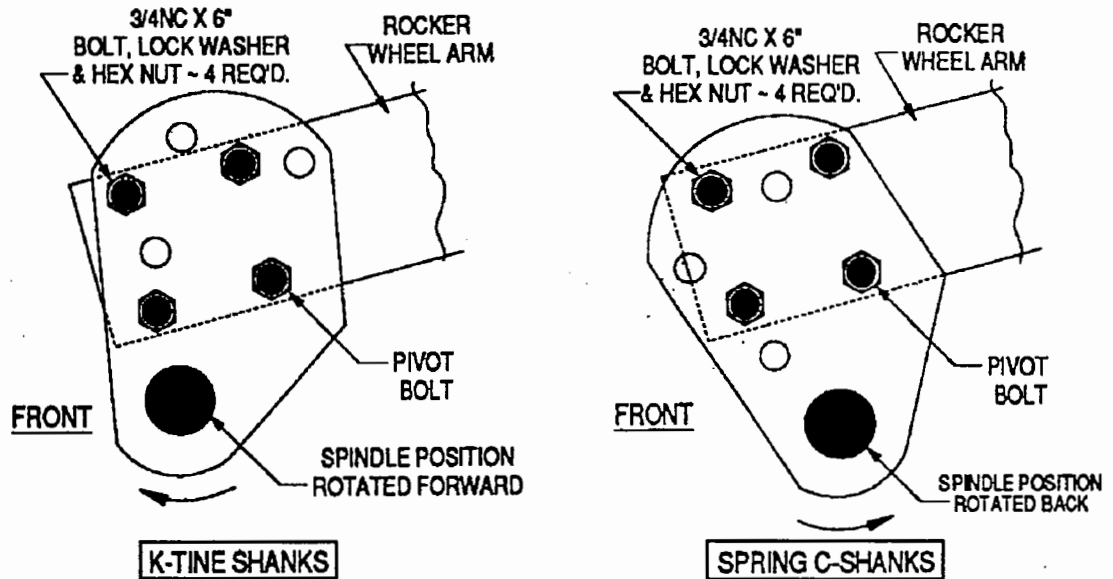

## 8. WING WALKING BEAM DUAL HUB ASSEMBLY (STANDARD ON 4231, 4237, 4241 WINGS / OPTIONAL ON 4218, 4223 & 4226 WINGS)

a. Locate walking beam hub assembly so that the grease zerk is on the top side and the front hub is toward the center of the cultivator.

b. Loosen the clamp bolt so that the side plates can slide onto the wheel arm.

c. Position the torsion spring toward the back with the legs under the wheel arm.

d. Fasten the walking beam to the wheel arm with FOUR 3/4NC x 6" Bolts, Lock Washers and Hex Nuts.

e. Tighten all FIVE 3/4NC x 6" bolts.

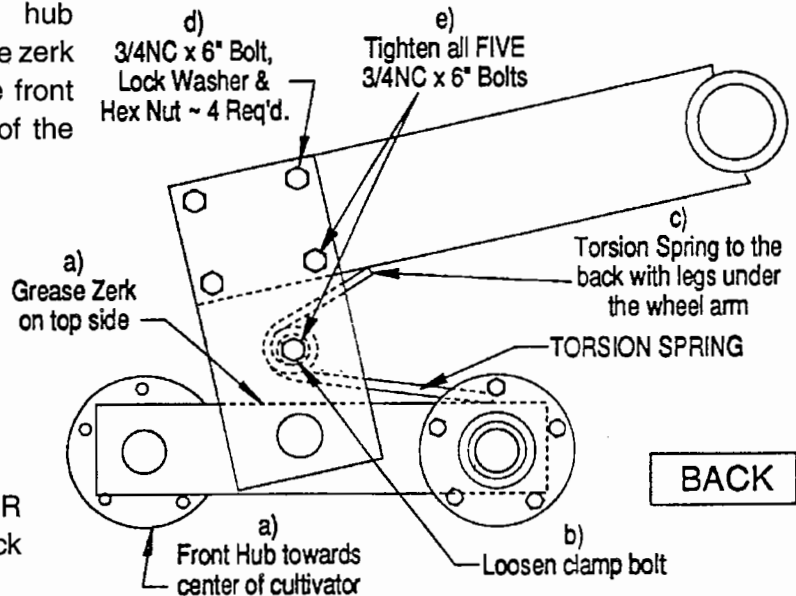

9. Remove the WHEEL BOLTS from the hubs and attach the WHEEL & TIRE ASSEMBLIES to the hubs.

TORQUE ALL WHEEL BOLTS FROM 90 TO 95 FOOT POUNDS.

NOTE: See placement pages at the back of this book for correct tire size for center and wing wheels.

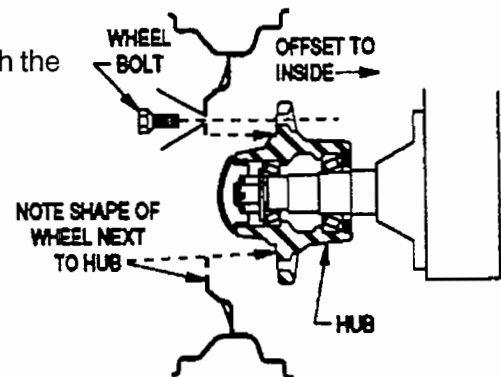

10. DEPTH STOP ASSEMBLY

- a. Attach the wing CYLINDER LUG to the frame with 3/4NC x 6" **GRADE 5** Bolts.

NOTE: Position 4218-17-0 Cylinder lug in **front** set of holes for single wheels. Position 4218-17-0 Cylinder lug in **rear** set of holes for walking beam dual wheels.

- b. Slide the depth stop assembly onto the top of the cylinder lug and in between the lug plates on the wing rocker.

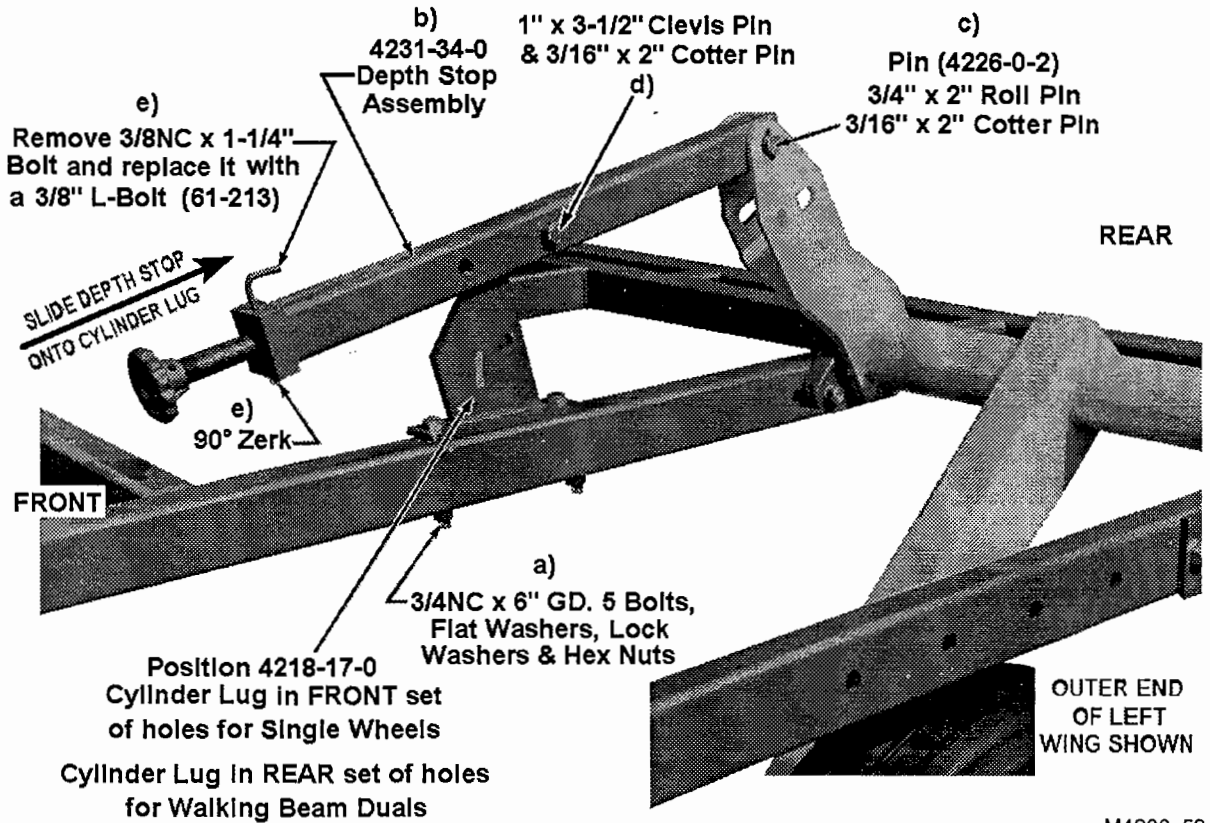

M4200-53

- c. Pin the depth stop assembly to the rocker lug with a PIN (4226-0-2), a 1/4" x 2" Roll Pin, and a 3/16" x 2" Cotter Pin.
- d. Insert a 1" x 3-1/2" Clevis Pin through the depth stop assembly and retain it with a 3/16" x 2" Cotter Pin.
- e. Remove the 3/8" x 1-1/4" Bolt in the depth stop assembly and replace it with a 3/8" L-BOLT (61-213).

## 11. WING LIFT LUG ASSEMBLY

- a. MODELS 4218 & 4223 Use GRADE 5 Bolts to fasten the wing lift lugs to the wing frames as shown at right.

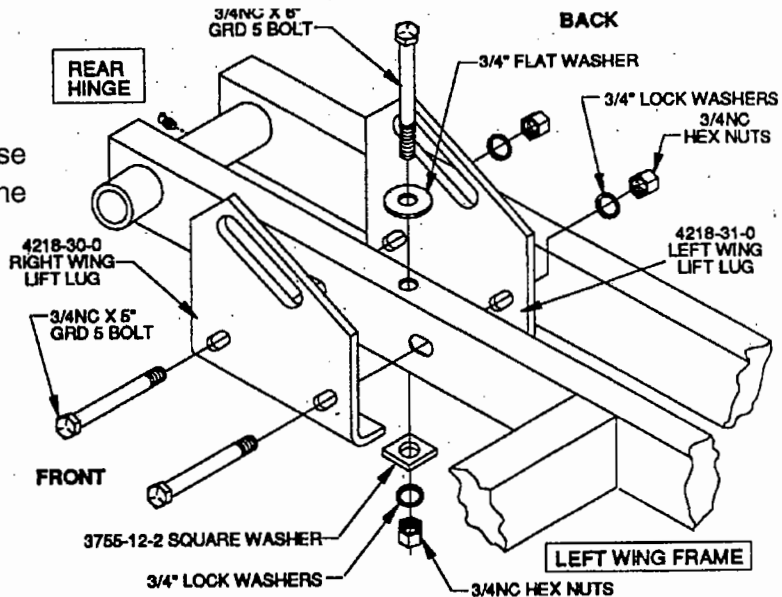

- b. MODELS 4226, 4231, 4237 & 4241

Use 3/4NC GRADE 5 Bolts to fasten the wing lift lugs to the wing frames as shown in the illustration to the right.

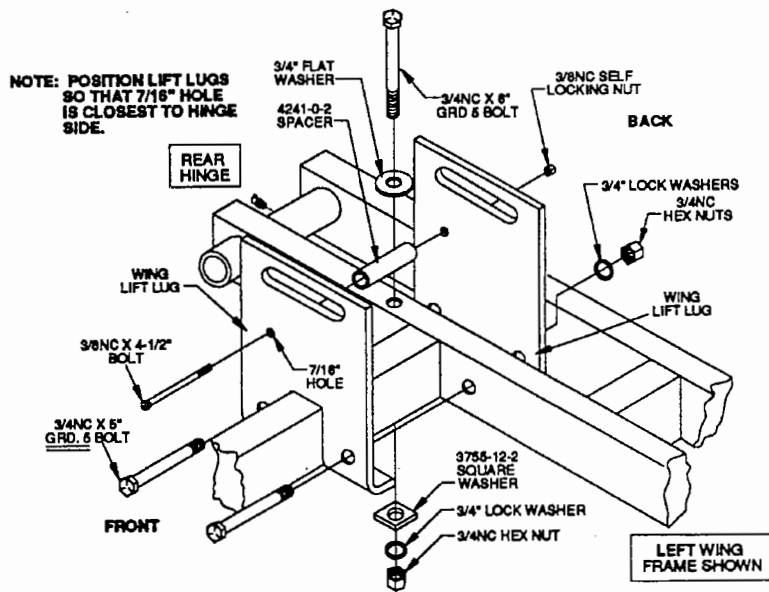

## 12. MODELS 4218, 4223, 4226 & 4231

Fasten the FRONT SHANK EXTENSION (4218-24-0) to the front wing frame 13-3/4" from the outer end with TWO 5/8NC U-BOLTS (61-126), Lock Washers and Hex Nuts.

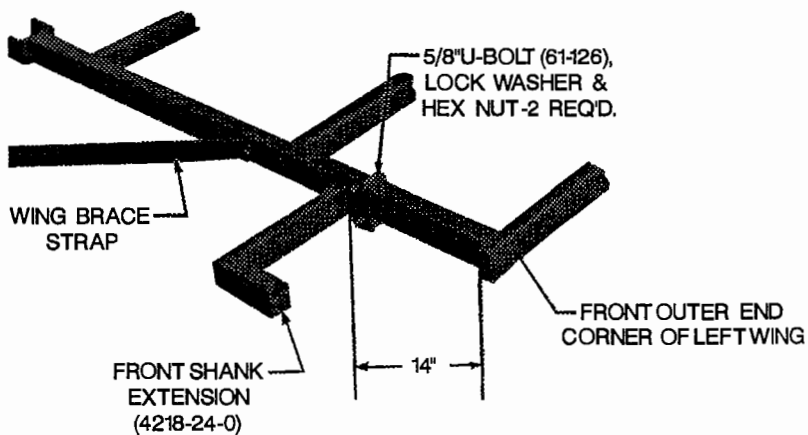

## IV. MODEL 4237 OUTER WING ASSEMBLY

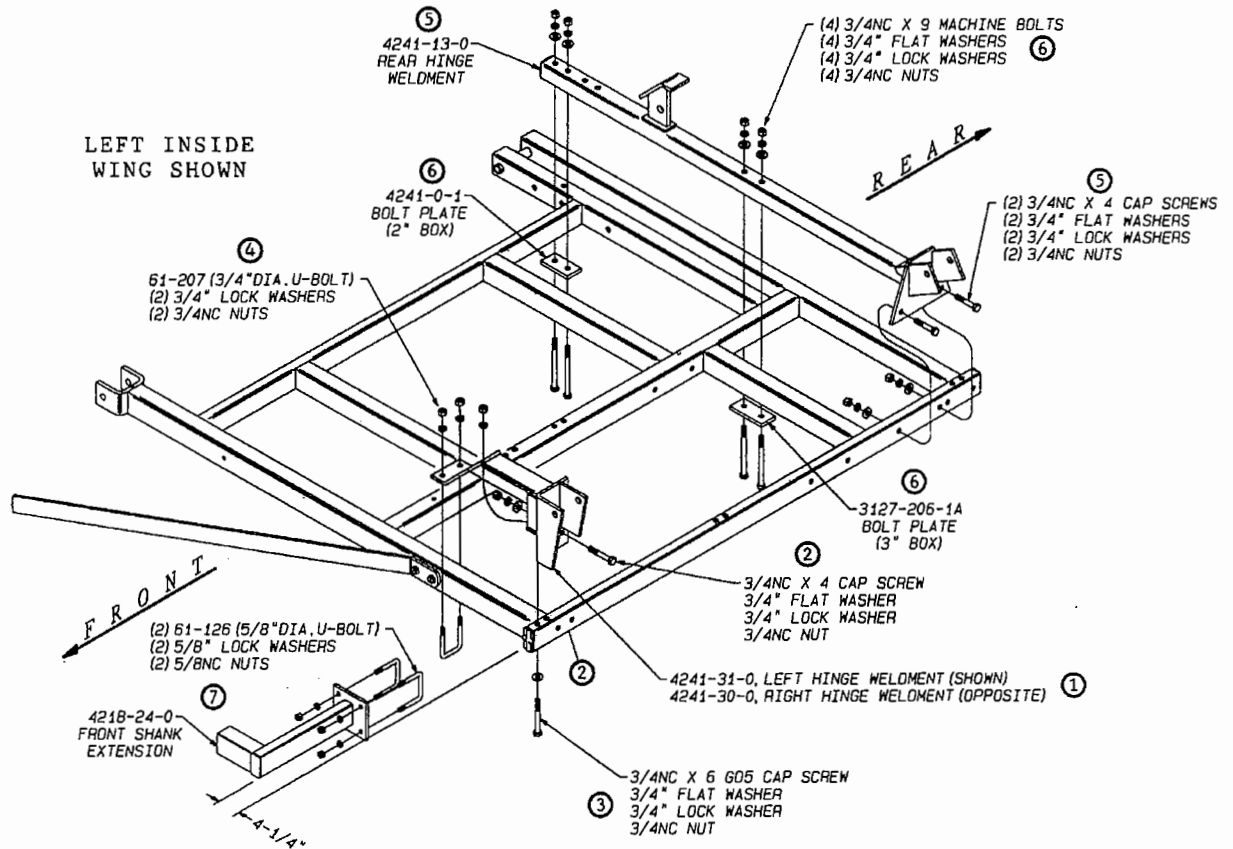

1. Position the FRONT WING HINGE onto the frame.
2. Fasten the HINGE to the outer frame tube with a 3/4NC x 4" Cap Screw, Flat Washer, Lock Washer and Hex Nut (DO NOT TIGHTEN).
3. Assemble a 3/4NC x 6" GD. 5 Cap Screw, Flat Washer , Lock Washer & Hex Nut vertically through the frame and HINGE WELDMENT.
4. Attach the inside end with a 61-207 (3/4" DIA. U-Bolt), Lock Washers and Hex Nuts.
5. Fasten the REAR HINGE to the outer frame box with (2) 3/4NC x 4" Cap Screws, Flat Washers, Lock Washers and Hex Nuts.
6. Finish the REAR HINGE ASSEMBLY by clamping it with 3127-206-1A BOLT PLATE, a 4241-0-1 BOLT PLATE, (4) 3/4NC x 9" Machine Bolts, Lock Washers and Hex Nuts.
7. Assemble the FRONT SHANK EXTENSION to the frame as shown with (2) 61-126 (5/8" DIA. U-Bolts), (4) Lock Washers, and (4) Hex Nuts.
8. TIGHTEN ALL BOLTS.
9. The OUTER WING ASSEMBLY on Model 4237 is the same as Model 4241. Follow steps through on pages A21 and A22.

## V. MODEL 4241 WING BRACE & OUTER WING ASSEMBLY

1. Attach the wing brace hinge clevis to the center frame with a HINGE BOLT (4122-43-0) and a 1NC Self Locking Nut.
2. Fasten the outer hinge clevis to the wing outer frame box with a 3/4NC x 4" Bolt, Flat Washer, Lock Washer and Hex Nut.
3. Assemble the brace to the top of the frame with a 3/4NC x 6" Bolt, Flat Washer, Lock Washer and Hex Nut.
4. Attach the brace to the front of the wing frame with 5/8" U-BOLTS (61-126), Lock Washers and Hex Nuts.

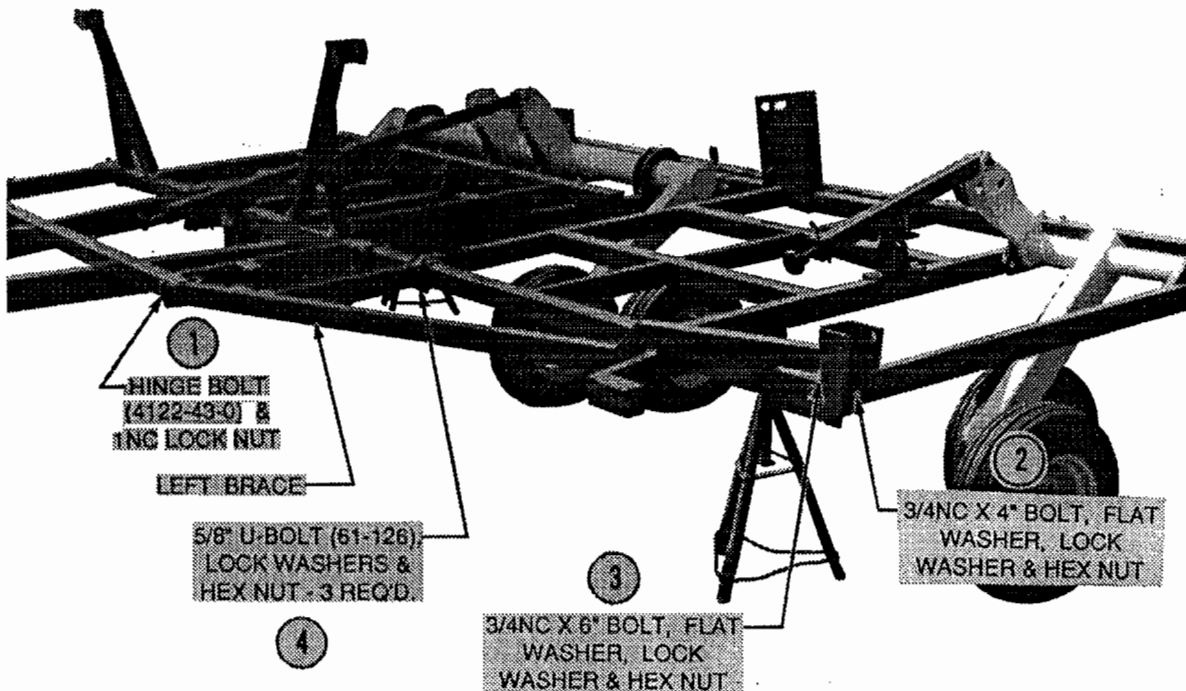

5. Assemble the outer end of the Rear Hinge Weldment to the end of the wing with TWO 3/4NC x 4" Bolts, Flat Washers, Lock Washers and Hex Nuts. (See photo on next page)
6. Position a BOLT PLATE (3127-206-1A) under the frame and fasten the center of the Rear Hinge Weldment to the Bolt Plate with TWO 3/4NC x 9" Bolts, Flat Washers, Lock Washer and Hex Nuts. (See photo on next page)
7. Position a BOLT PLATE (4241-0-1) under the frame and fasten the inside end of the Rear Hinge Weldment to the Bolt Plate with TWO 3/4NC x 9" Bolts, Flat Washers, Lock Washers and Hex Nuts.
8. Tighten all assembled bolts.

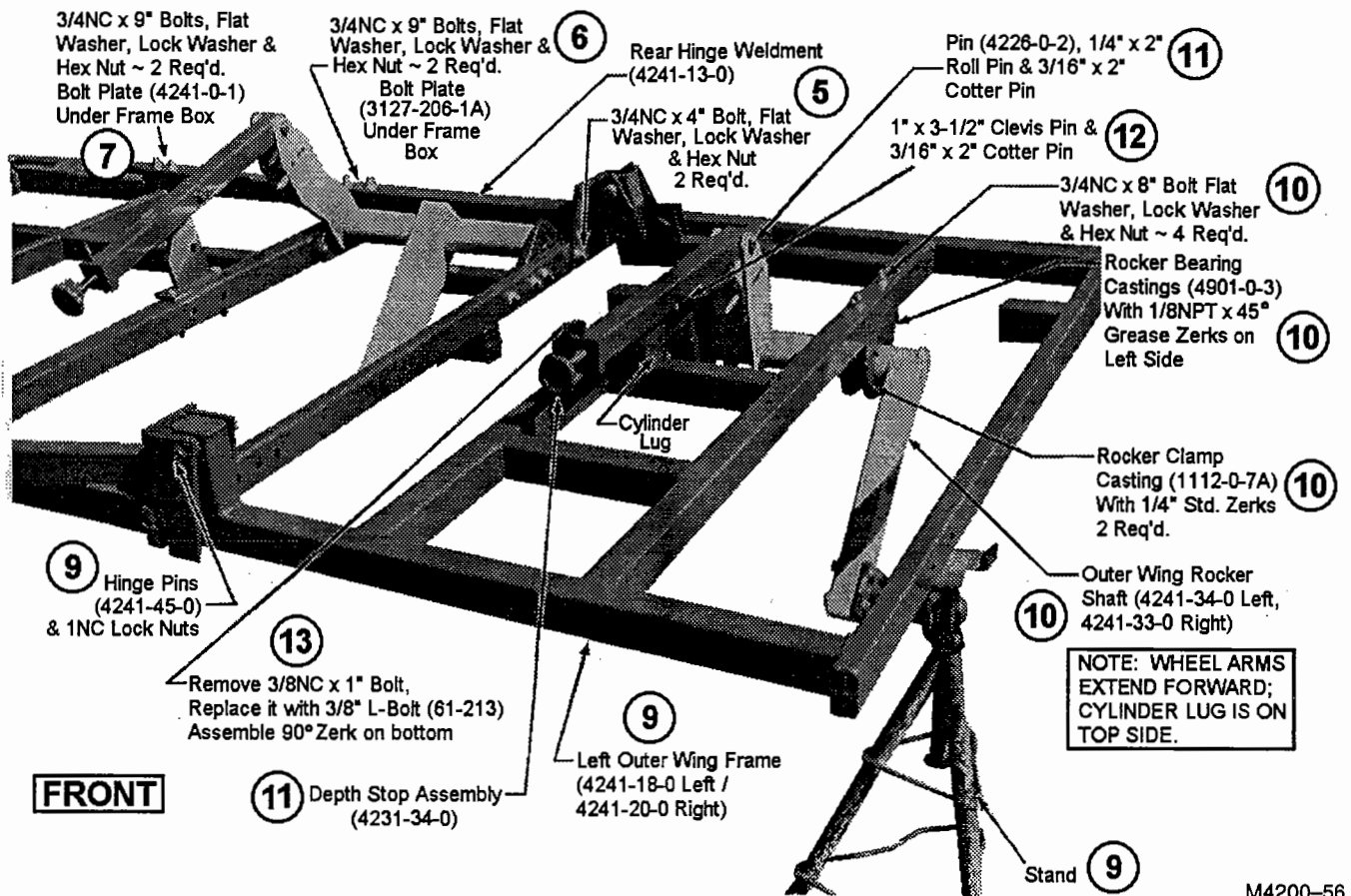

9. Attach the outer wing frame with HINGE PINS (4241-45-0) and 1NC Self Locking Nuts. Support the outer end of the frame with a stand.
10. Screw in 1/8NPT x 45 degree zerks into the ROCKER BEARING CASTINGS (4901-0-3). Screw in 1/4NPT STD. zerks into the ROCKER CLAMP CASTINGS (1112-0-7A). Attach the wing rocker to the frame with 3/4NC x 8" Bolts, Flat Washers, Lock Washers and Hex Nuts.
11. Slide the depth stop assembly onto the top of the cylinder lug and in between the lug plates on the rocker shaft. Fasten it in place with a PIN (4226-0-2), a 1/4" Roll Pin and a 3/16" x 2" Cotter Pin.
12. Insert a 1" x 3-1/2" Clevis Pin through the depth stop assembly and retain it with a 3/16" x 2" cotter pin.
13. Remove the 3/8NC x 1-1/4" Bolt in the depth stop assembly and replace it with a 3/8" L-BOLT (61-213).
14. Fasten HUB ASSEMBLY (1918-17-0) to outer wing wheel arm with 3/4NC x 5" Bolt, Flat Washers, Lock Washers and Hex Nuts.

NOTE: YELLOW PATCH IS ON THE TOP SIDE OF THE WHEEL ARM.

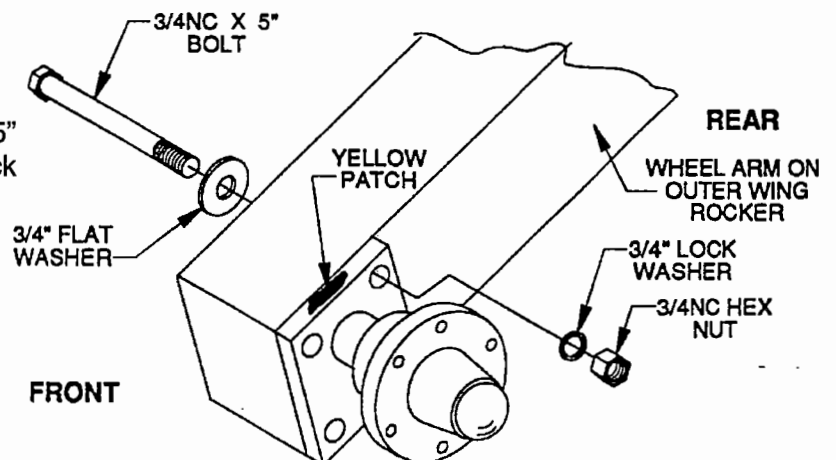

- Remove WHEEL BOLTS from the hubs and attach the WHEEL & TIRE ASSEMBLIES to the hubs.

TORQUE ALL WHEEL BOLTS FROM 90 TO 95 FOOT POUNDS.

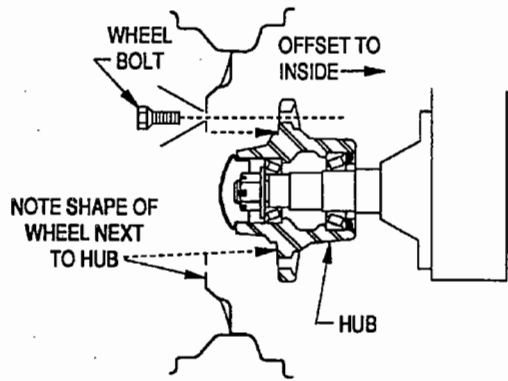

## VI. SHANK EXTENSION ASSEMBLY (ALL MODELS)

A folding extension is offered on Model 4231 ONLY.

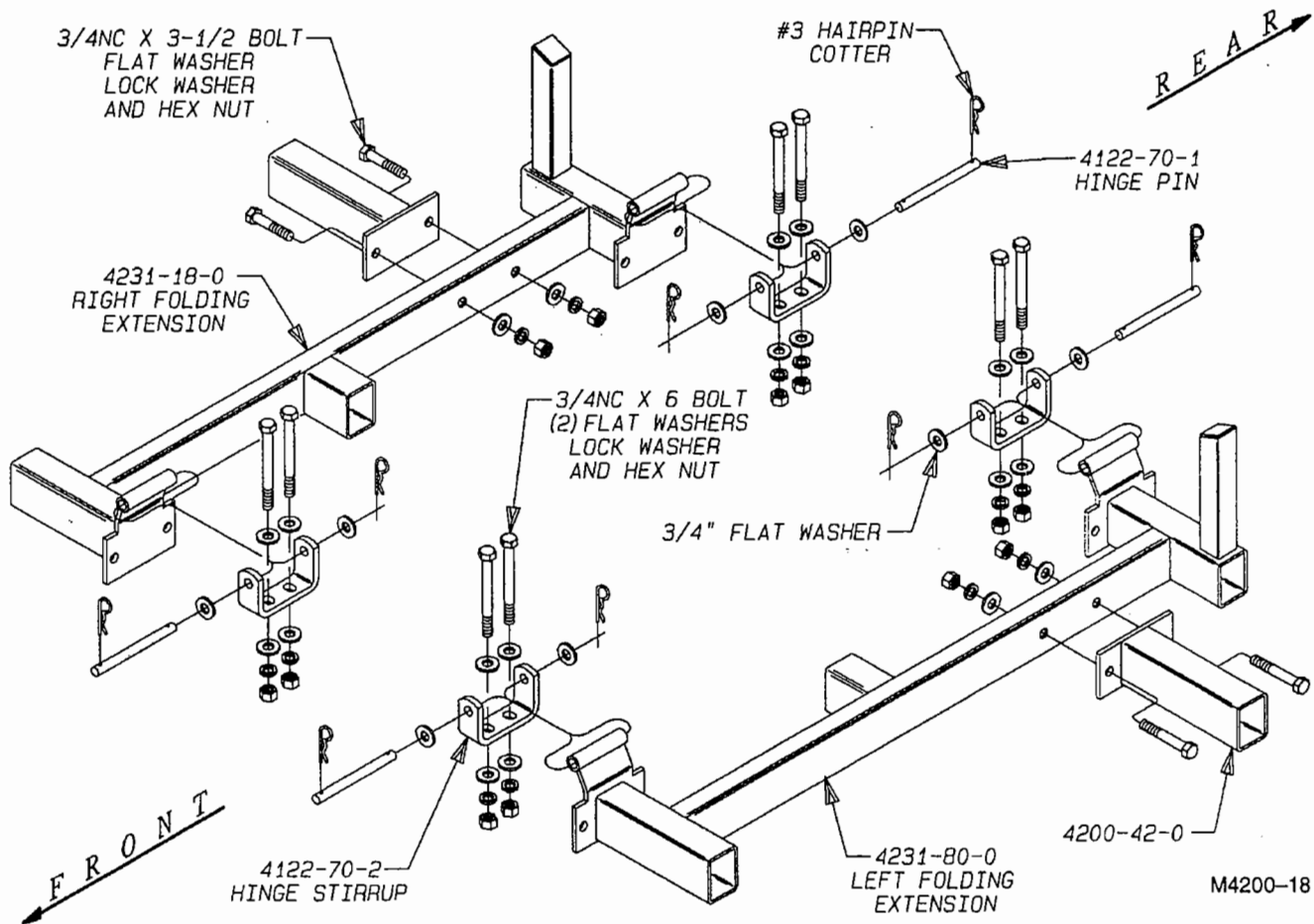

## MODEL 4231 2 & 3 SHANK FOLDING EXTENSION

U-BOLTED SHANK EXTENSIONS are used as needed at various locations within the frame as well as for add-on extension to the wings.

There are (3) different EXTENSIONS – 6", 12", and 18-1/2".

There are (2) different U-BOLTS – For 2 x 4 Frame Box , and For 3 x 4 Frame Box.

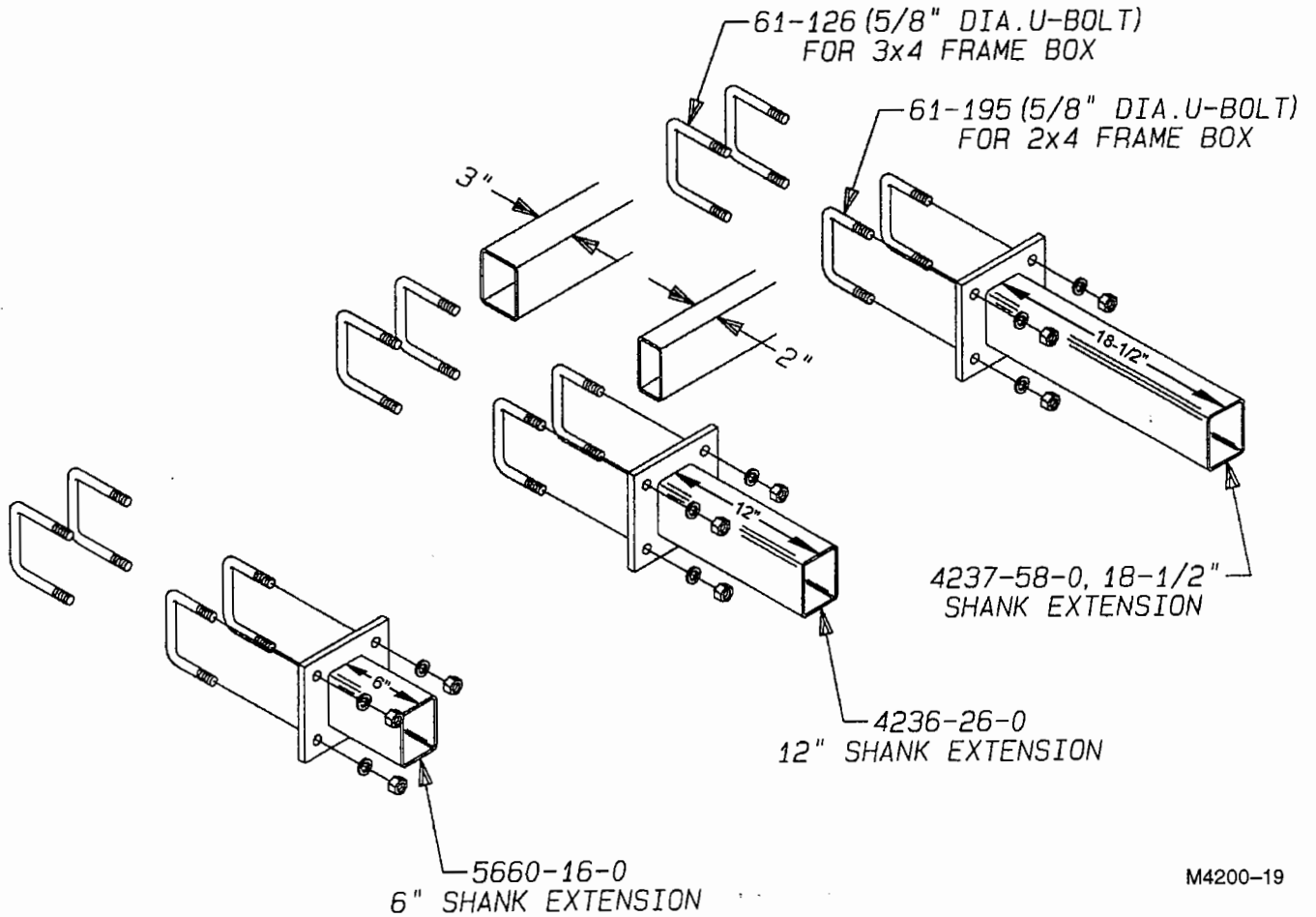

M4200-19

The shank placement pages at the back of this manual will show the locations for the extensions. Determine the extension length and the U-Bolts required and assemble as shown in the placement drawing.

## VII. SHANK ASSEMBLY

### SPRING C-SHANKS

1. Refer to the placement drawing at the back of the book for shank locations.
2. Bolt Sweep or Point to Shank with TWO 3/8NC x 1-1/2" GRADE 5 Plow Bolts. A 3/8" Flat Washer is required next to the slotted hole.
3. Clamp the shank assembly to the frame box with a Mounting Strap (3127-25-2), 1/2NC x 2" GRADE 8 Bolts, SQUARE DOUBLERS (3127-25-3), and 1/2NC Self Locking Nuts.

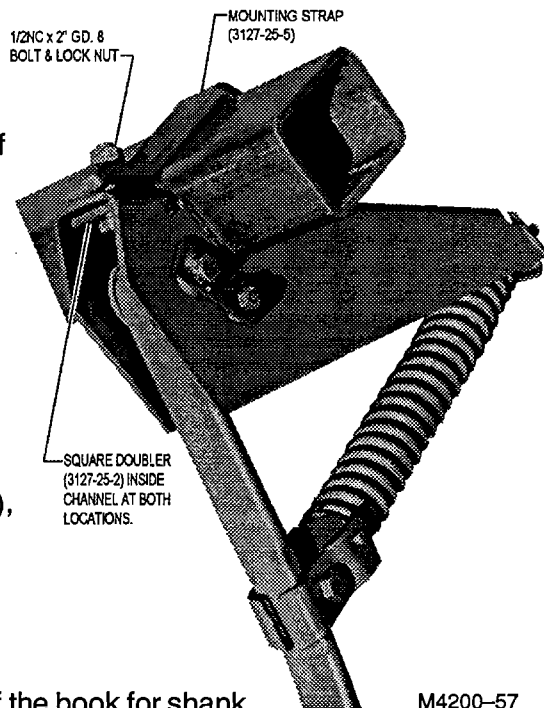

M4200-57

### K-TINE SHANKS

- a. Refer to the placement drawing at the back of the book for shank location and type of mounting.
- b. Bolt Sweep or Point to the shank with TWO 3/8NC x 1-1/2" GRADE 5 Plow Bolts. A 3/8" Flat Washer is required next to the slotted hole.
- c. There are FOUR different types of K-Tine Mountings.
  - a. Standard Rear Mount

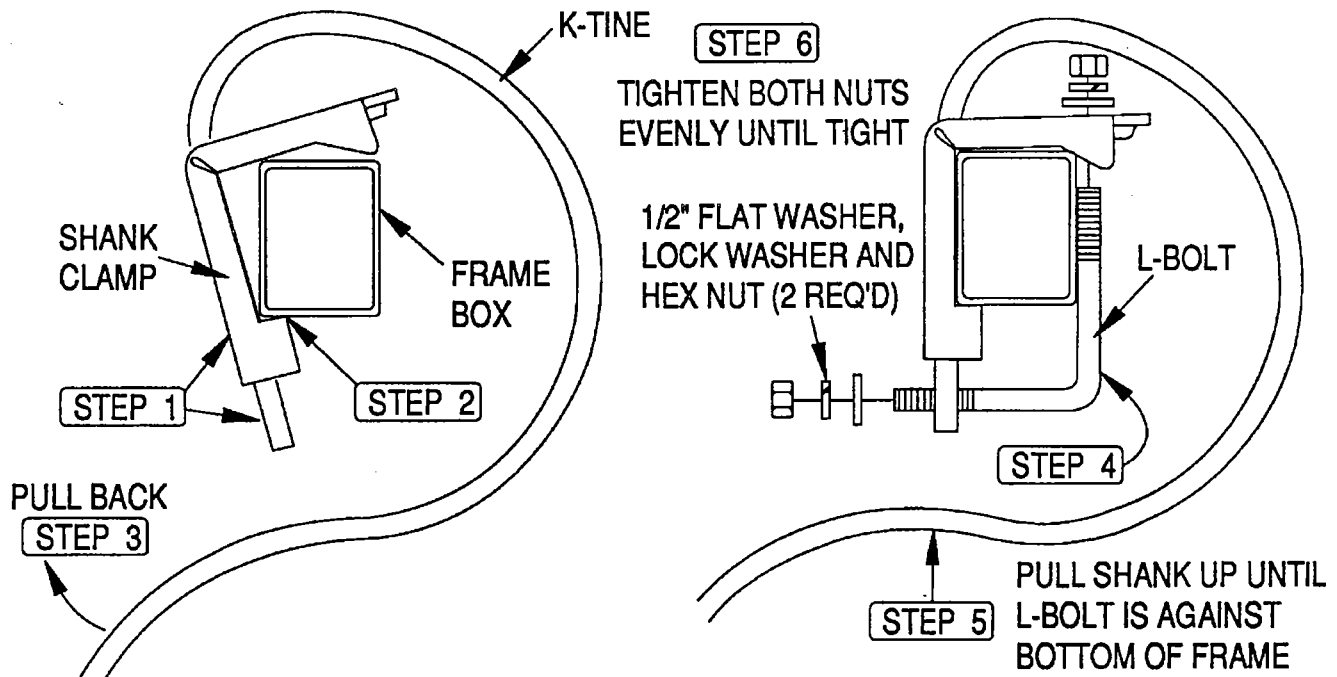

b. Front Mount

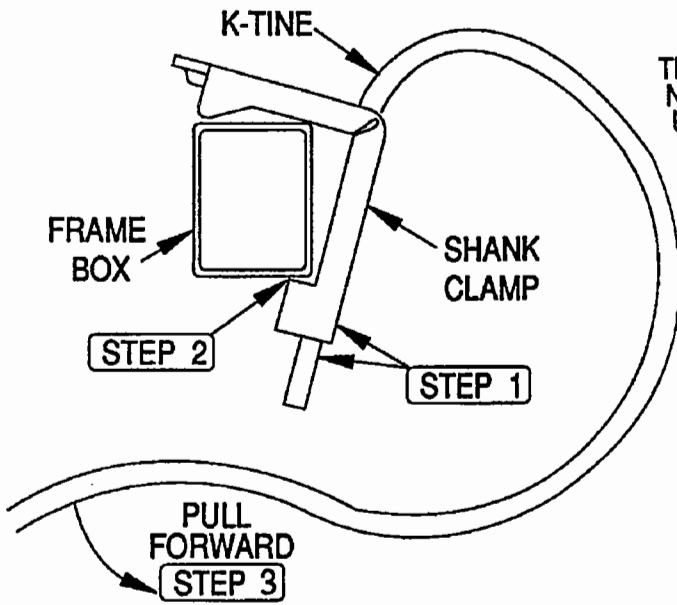

STEP 6  
TIGHTEN BOTH  
NUTS EVENLY  
UNTIL TIGHT

L-BOLT

1/2" FLAT WASHER,  
LOCK WASHER AND  
HEX NUT (2 REQ'D)

STEP 4

STEP 5

PULL SHANK UP UNT  
L-BOLT IS AGAINST  
BOTTOM OF FRAME

c. Rear Extended Mount

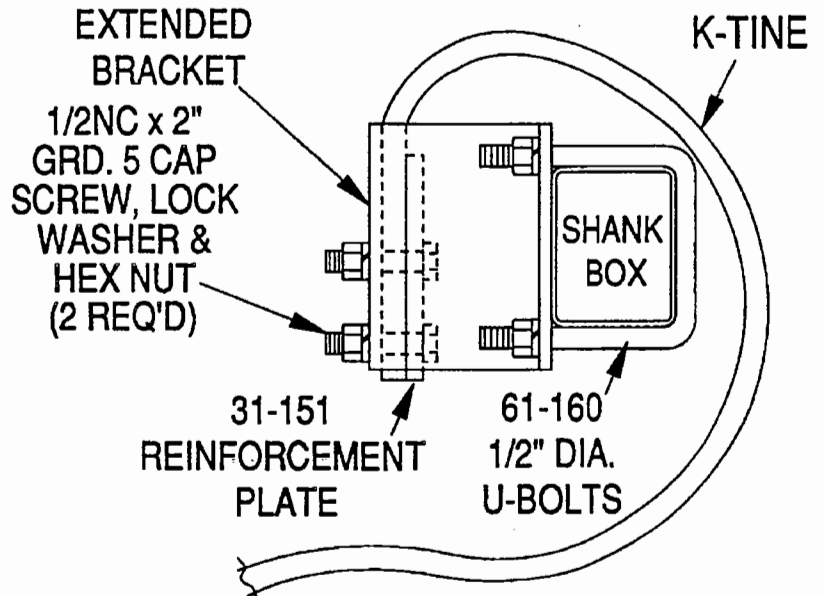

d. Front Extended Mount

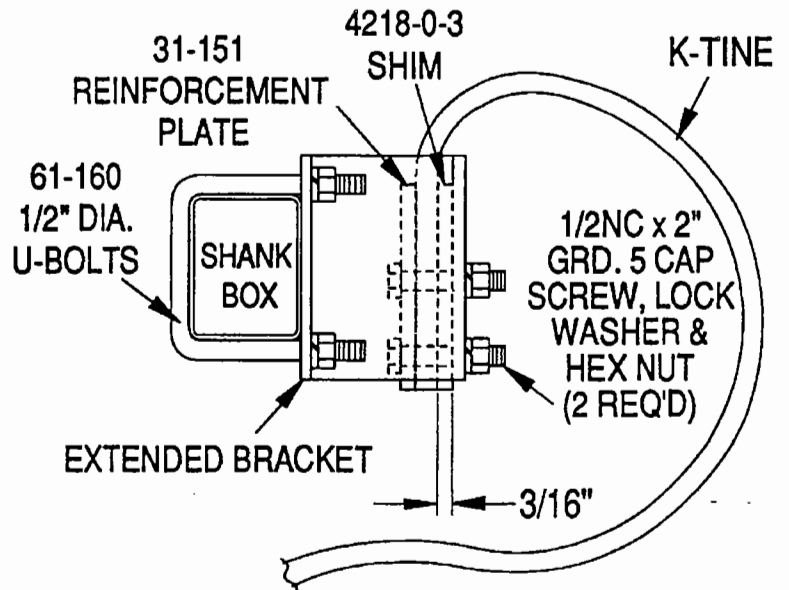

## 2-PIECE K-TINE SHANKS

- Refer to the Placement Drawings at the back of this manual for shank location and type of mounting.
- There are SEVEN different types of 2-Piece K-Tine Mountings. See illustrations below.

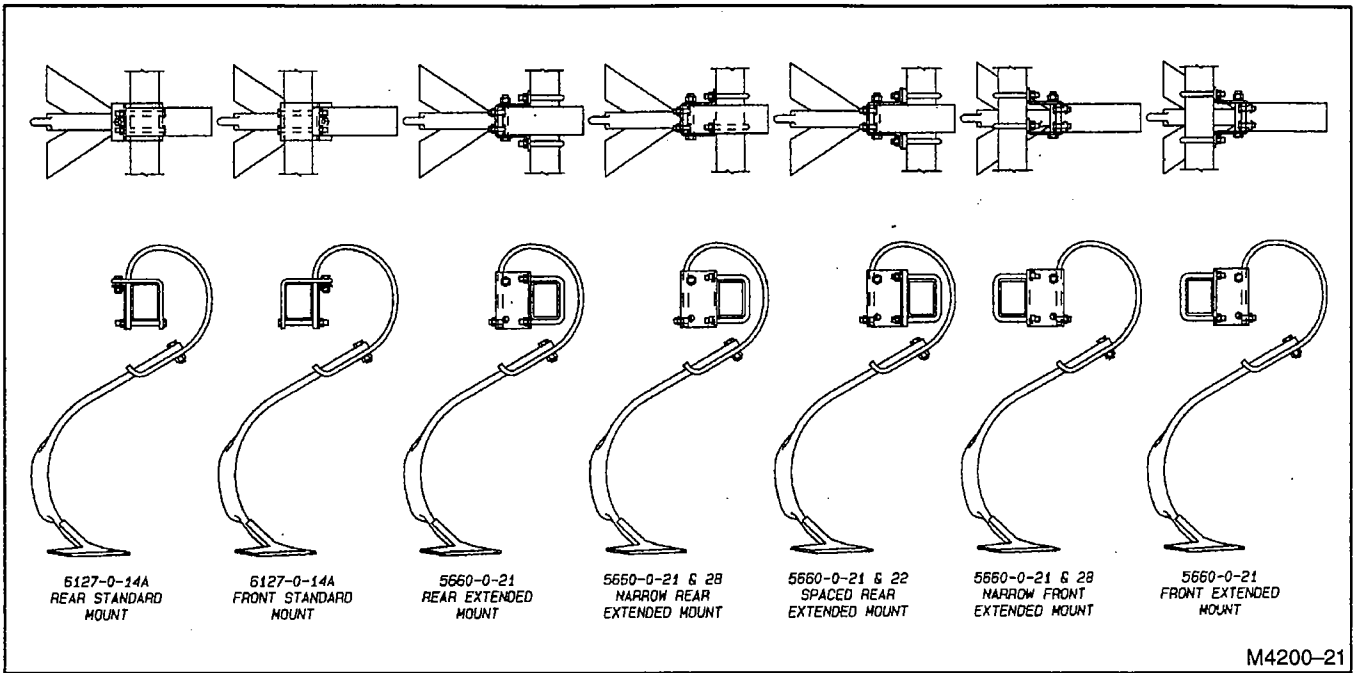

### c. Rear Standard Mounting

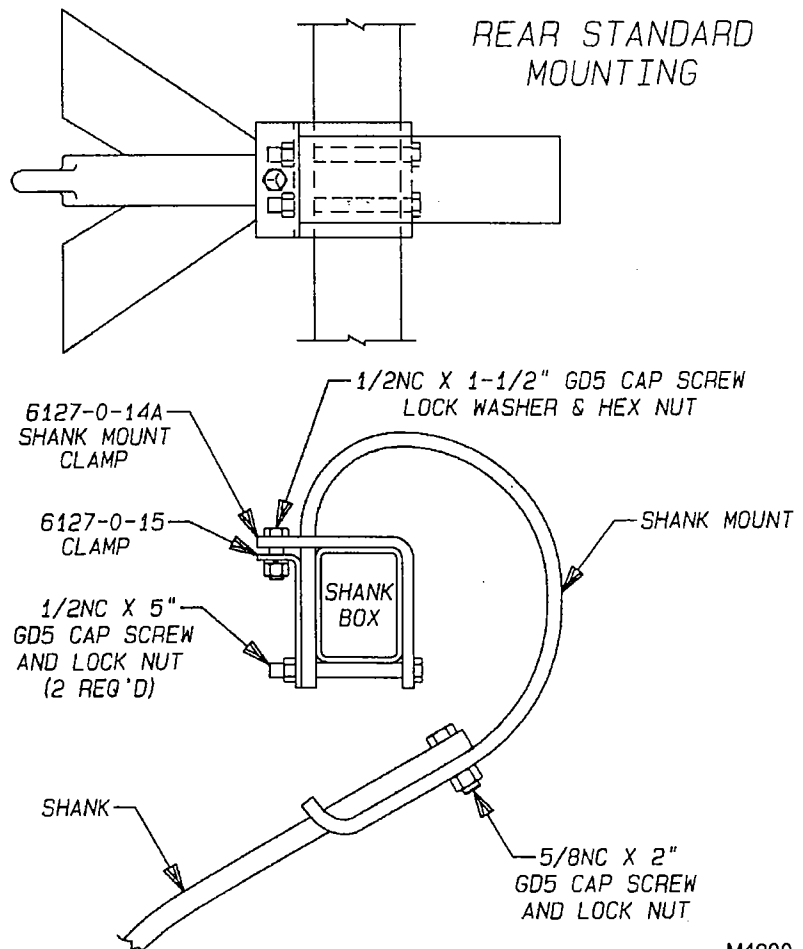

d. Front Standard Mounting

FRONT STANDARD MOUNTING

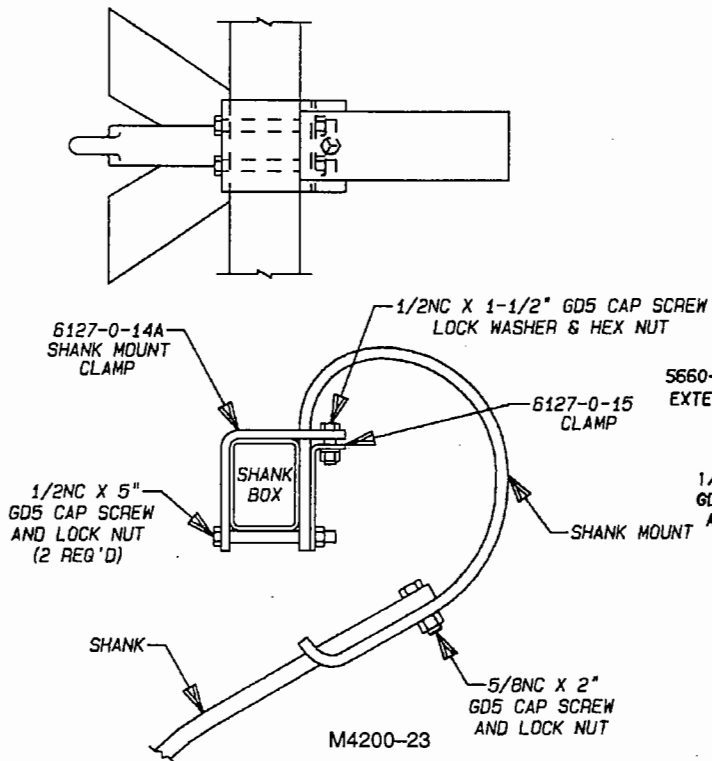

e. Rear Extended Mounting

REAR EXTENDED MOUNTING

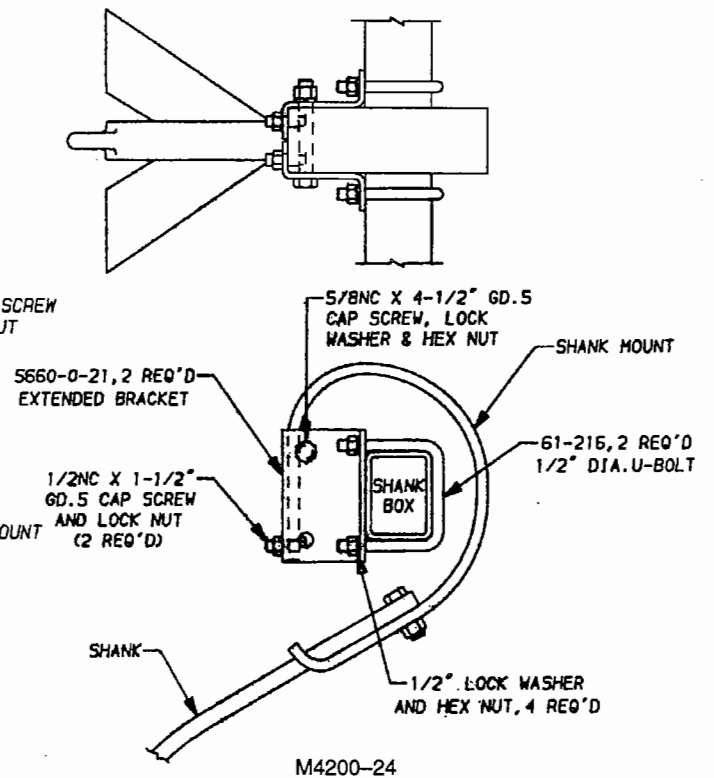

f. Spaced Rear Extended Mounting

SPACED REAR EXTENDED MOUNTING

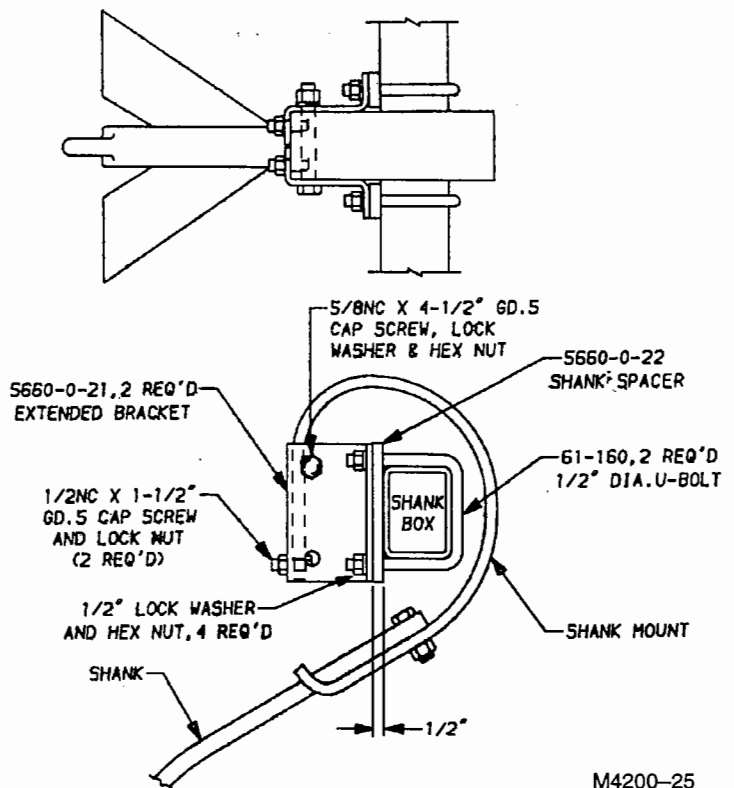

g. Narrow Front Extended Mounting

NARROW FRONT EXTENDED MOUNTING

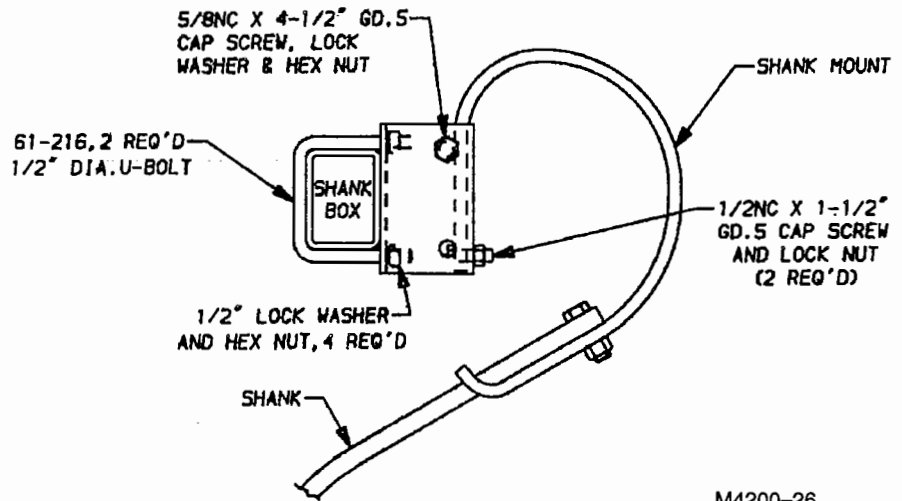
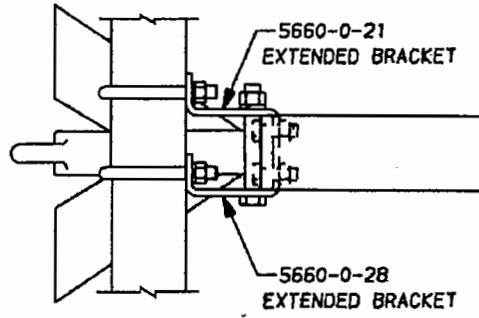

M4200-26

FRONT EXTENDED MOUNTING

h. Front Extended Mount

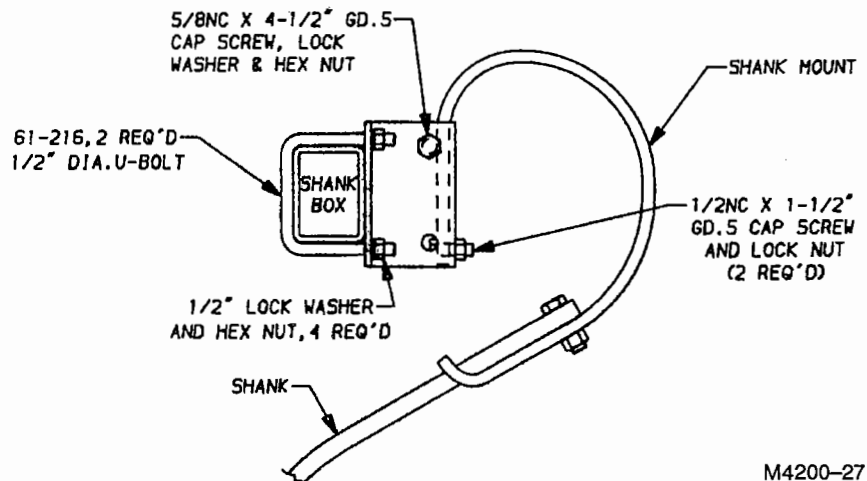
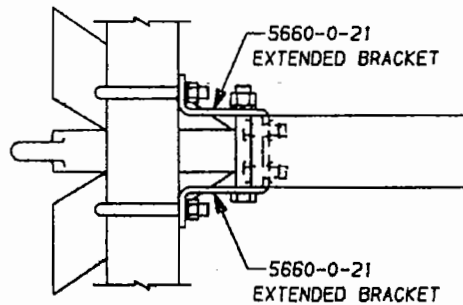

M4200-27

## VIII. HYDRAULICS

- Determine the correct size and location of the rocker and wing lift cylinders from the chart below.

MODEL NUMBER	4218	4223	4223 OPTION	4226	4231	4237	4241	4241 OPTION
CENTER ROCKER CYLINDER	22-126 4-1/2 x 8	22-126 4-1/2 x 8	21-163 4-3/4 x 8	(2) 22-126 4-1/2 x 8	(2) 22-126 4-1/2 x 8	(2) 22-126 4-1/2 x 8	(2) 22-126 4-1/2 x 8	(2) 21-163 4-3/4 x 8
LEFT WING ROCKER CYLINDER	22-125 4-1/4 x 8	22-125 4-1/4 x 8	22-126 4-1/2 x 8	22-125 4-1/4 x 8	22-125 4-1/4 x 8	22-125 4-1/4 x 8	22-125 4-1/4 x 8	22-126 4-1/2 x 8
RIGHT WING ROCKER CYLINDER	22-122 4 x 8	22-122 4 x 8	22-125 4-1/4 x 8	22-125 4-1/4 x 8	22-125 4-1/4 x 8	22-125 4-1/4 x 8	22-125 4-1/4 x 8	22-126 4-1/2 x 8
LEFT OUTER WING ROCKER CYLINDER	-----	-----	-----	-----	-----	-----	22-122 4 x 8	22-125 4-1/4 x 8
RIGHT OUTER WING ROCKER CYLINDER	-----	-----	-----	-----	-----	-----	22-122 4 x 8	22-125 4-1/4 x 8
WING LIFT	(2) 22-110 4 x 16	(2) 22-110 4 x 16	(2) 21-110 4 x 16	(2) 21-107 4 x 32	(2) 21-107 4 x 32	(2) 21-107 4 x 32	(2) 21-107 4 x 32	(2) 21-107 4 x 32
OUTER WING LIFT	-----	-----	-----	-----	-----	21-138 4 x 24	21-138 4 x 24	21-138 4 x 24

- Pin the base end of each rocker hydraulic cylinder to the frame lug using cylinder pin.

NOTE: the ports are up on the center frame and down on the wings. (See illustration below)

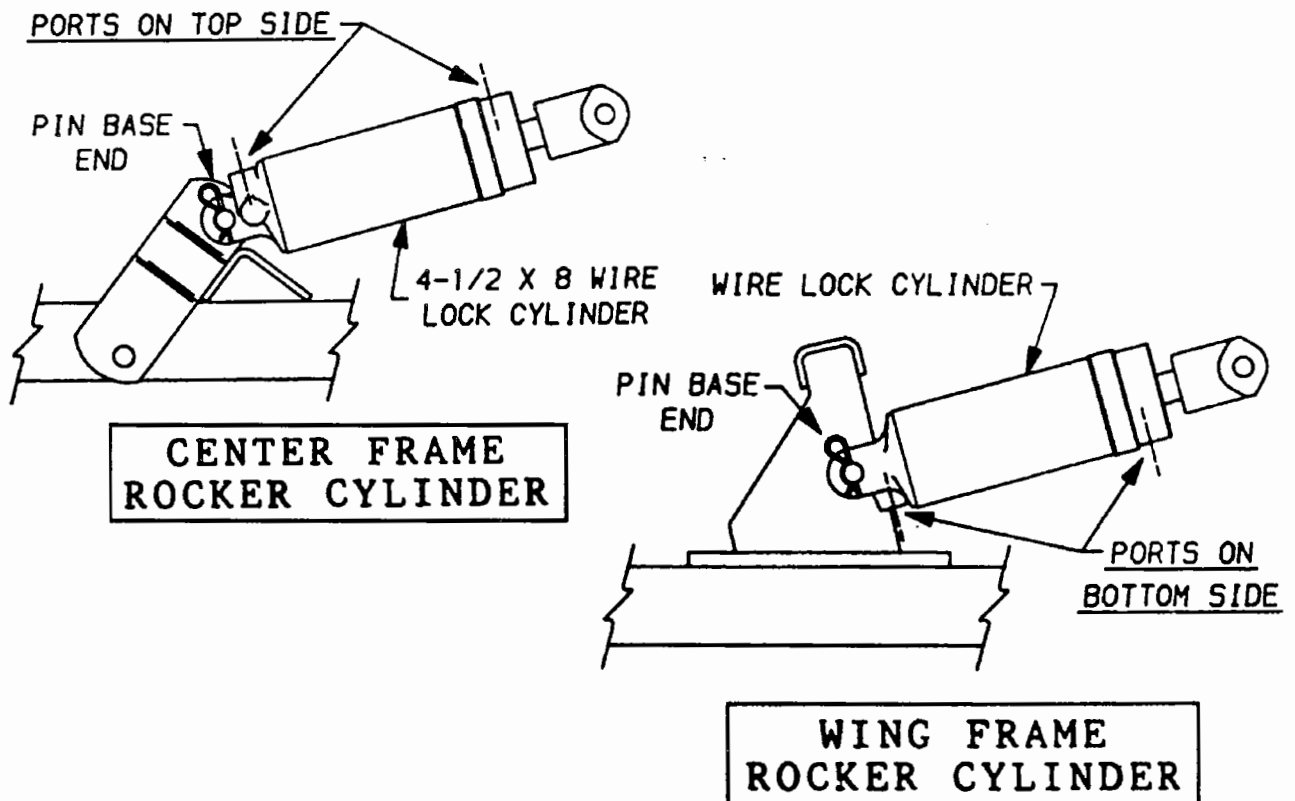

- Loosen the plastic port plugs on the rocker cylinders and extend them until the rod end clevis aligns with the slot in the rocker lug. Pin the rod end with Krause supplied pins and roll pins as shown in the drawing below.

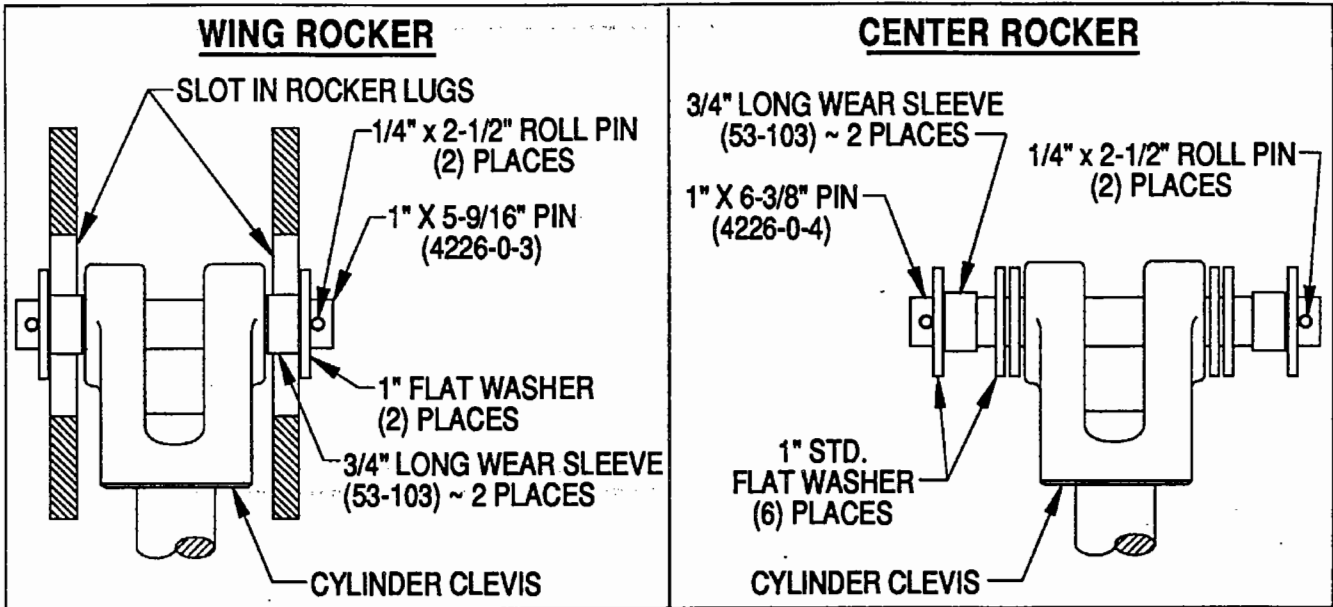

- Pin the base end of each wing lift hydraulic cylinder to the frame lug using a cylinder pin.

NOTE: a) The ports should face the rear of the cultivator.

b) Support the cylinder with a wood block so that the rod end can extend without being obstructed.

**IMPORTANT:** DO NOT PIN THE ROD ENDS OF THE CYLINDERS TO THE LIFT LUGS UNTIL ALL HYDRAULIC ASSEMBLY IS COMPLETE AND THE SYSTEMS HAVE BEEN PURGED OF AIR AND FILLED AND WITH OIL.

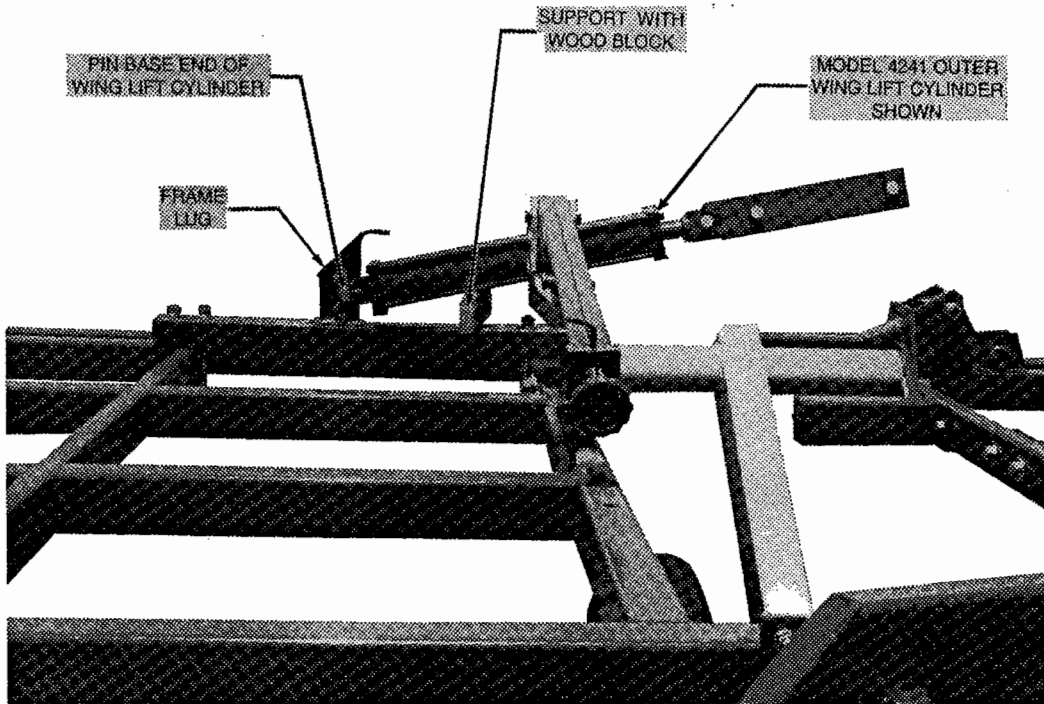

**⚠ Caution:** Use only hose that meets or exceeds 3,000 PSI working pressure.

5. Using the hose drawings in the Parts Section, assemble all hoses, fittings and hose clamps as shown.

**IMPORTANT:** MAKE SURE WING LIFT CYLINDERS ARE ASSEMBLED WITH RESTRICTORS IN THE ROD END PORTS.

6. Use the following photographs to aid in hose assembly and clamping:

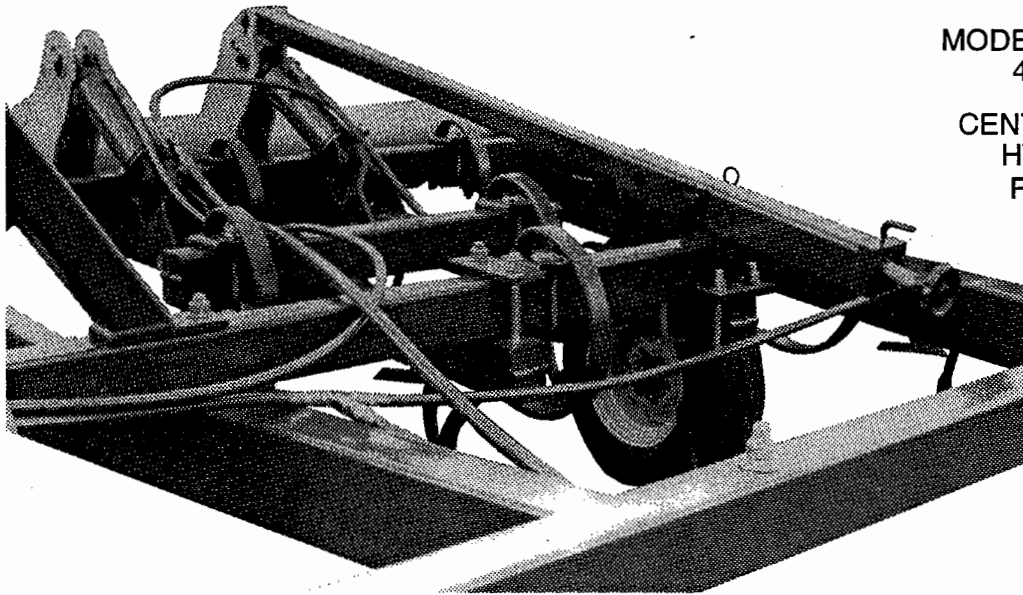

MODELS 4226, 4231,  
4237, 4241

CENTER ROCKER  
HYDRAULIC  
PLUMBING

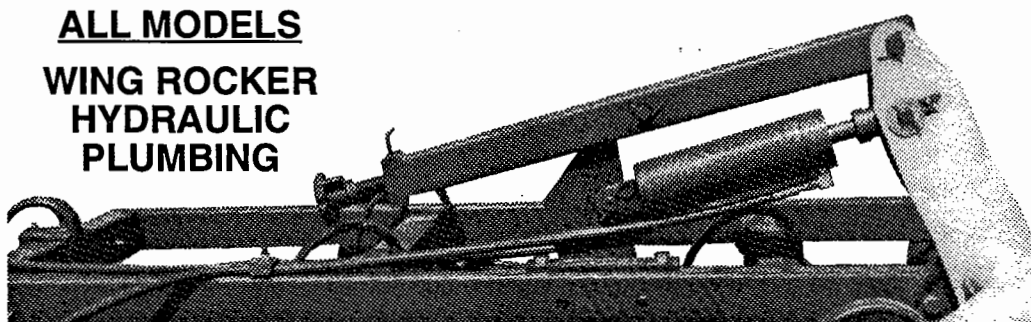

**ALL MODELS**  
WING ROCKER  
HYDRAULIC  
PLUMBING

3514-0-2  
HOSE CLAMP

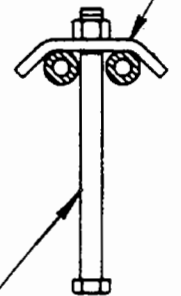

1/2NC X 6" BOLT  
AND LOCK NUT

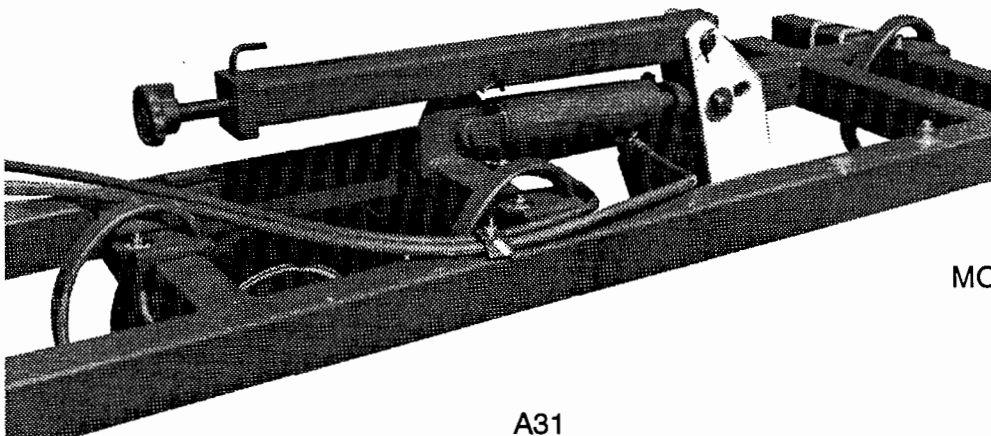

MODEL 4237 & 4241.

OUTER WING  
ROCKER  
HYDRAULIC  
PLUMBING

# MODEL 4241

(Similar on other models)

## HOSE CLAMP ASSEMBLY ALONG FRONT WING FRAME BOX

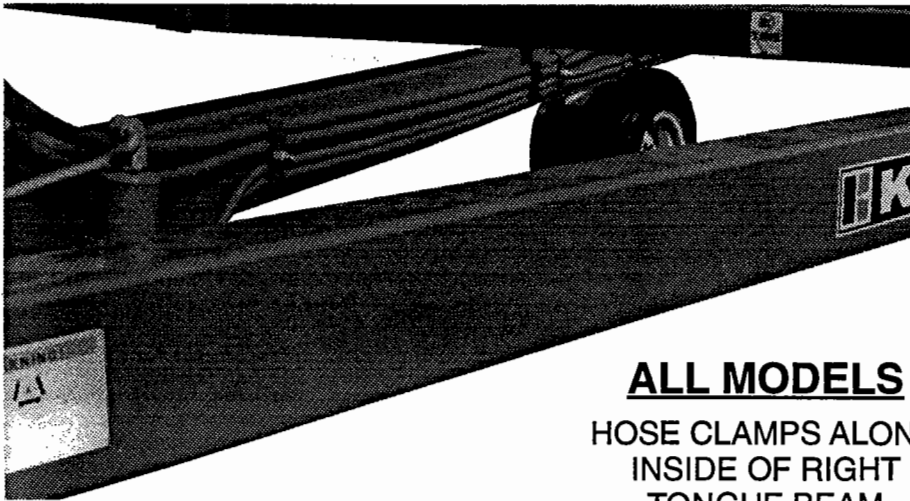
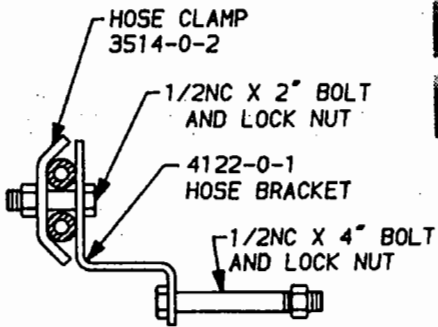

## ALL MODELS HOSE CLAMPS ALONG INSIDE OF RIGHT TONGUE BEAM

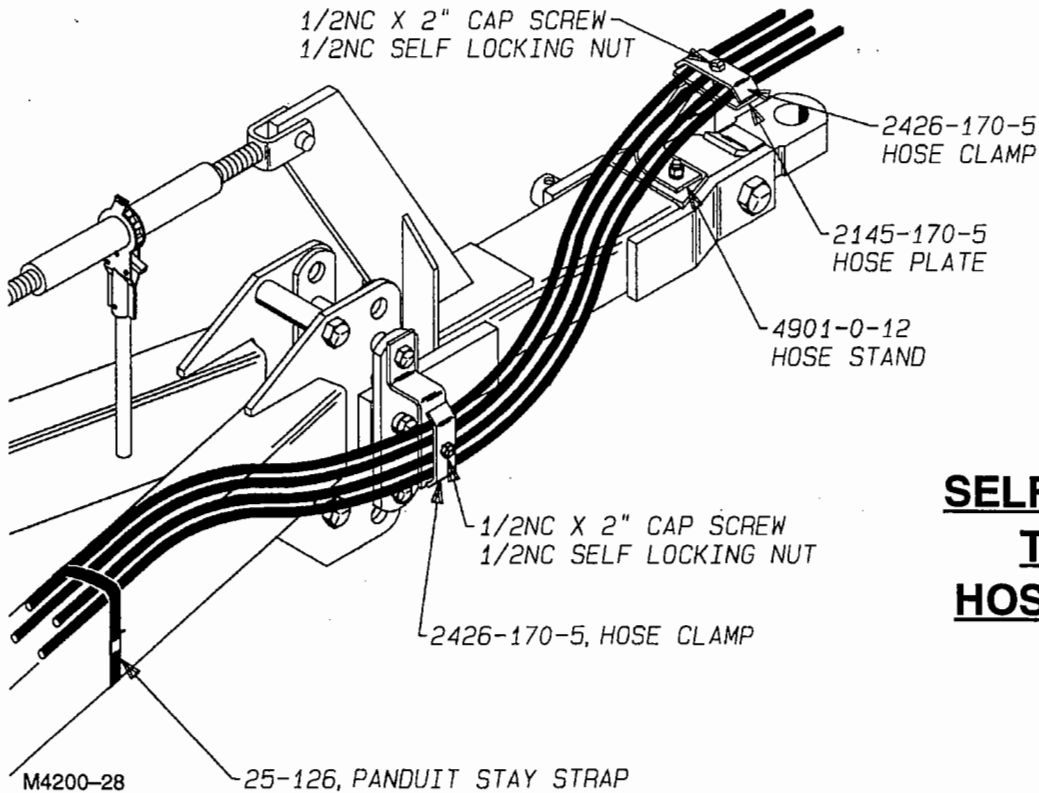
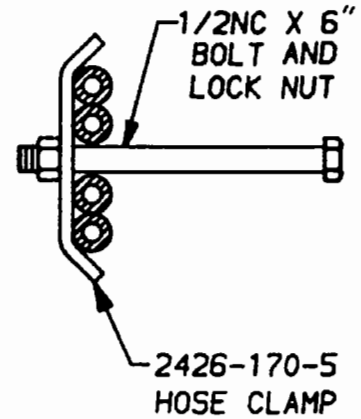

## SELF LEVELING TONGUE HOSE CLAMPS

7. MODEL 4237 & 4241 WING FOLD  
Sequence Valve Assembly (See parts listing below)

- |       |                                     |       |  |
|-------|-------------------------------------|-------|--|
| 1 ... | 25-144 Sequence Valve               | 9 ..  | 25-310 37° Flare Male / Female 90 Ell  |
| 2 ... | 4241-0-3 Mounting Bracket           | 10 .. | 37° Flare In-Line Restrictor   |
| 3 ... | 1/4" x 6-1/2" GD. 5 Bolt & Lock Nut | 11 .. | 25-324 Hose 3/8" x 207" (JIC)  |
| 4 ... | 1/4" x 2-3/4 GD. 5 Bolt & Lock Nut  | 12 .. | 25-248 Hose 3/8" x 214" (JIC)  |
| 5 ... | 25-320 O-Ring 37° Flare 90° Female  | 13 .. | 25-266 Hose 3/8" x 21" (JIC)   |
| 6 ... | 25-302 O-Ring 37° Flare Tee         | 14 .. | 24-246 Hose 3/8" x 28" (JIC)   |
| 7 ... | 25-307 37° Flare Male / Female Tee  | 15 .. | 24-242 Hose 3/8" x 161" (JIC) Model 4241<br>24-265 Hose 3/8" x 135" (JIC) Model 4237 |
| 8 ... | 25-303 37° Flare Male Tee           | 16 .. | 24-210 Hose 3/8" x 74" (JIC)   |
|       |                                     | 17 .. | 24-240 Hose 3/8" x 107" (JIC) Model 4241<br>24-212 Hose 3/8" x 79" (JIC) Model 4237  |

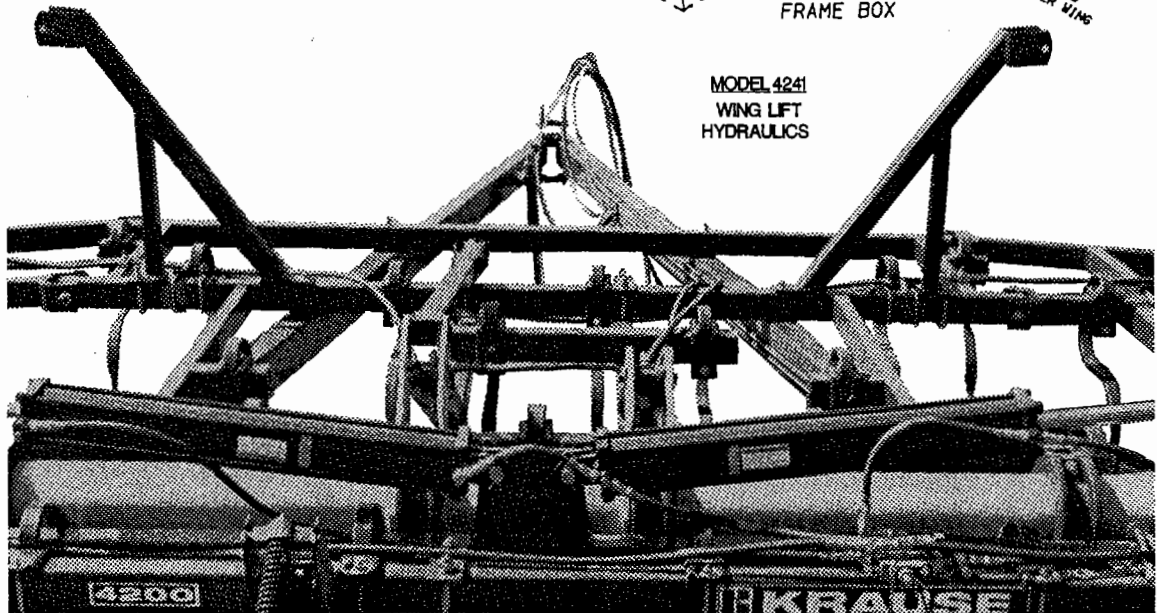
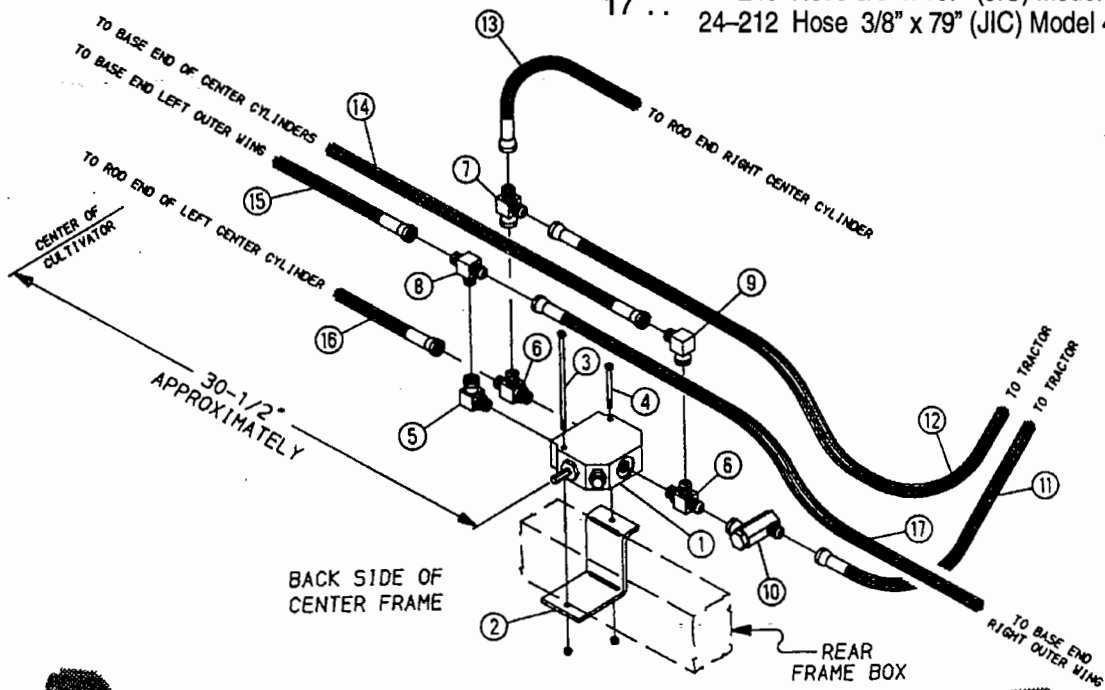

VIEW FROM BEHIND CULTIVATOR

SEQUENCE VALVE LOCATION

8. CHARGING THE CYLINDERS –

- a. After all hose and fittings are assembled, check the blocks under the wing cylinders. Make sure they are raised high enough to clear any attaching lugs.
- b. Attach hydraulic hoses to the tractor. Check the tractor hydraulic reservoir and make sure it is full of the manufacturer's recommended oil.
- c. If you are sure all connections are tight and leakproof, begin filling the system by extending and retracting the cylinders.
- d. The rocker shaft cylinders have rephasing grooves that will allow the oil to pass by the piston when the cultivator is fully raised. Hold the control lever open during each cycle when the cultivator is raised and the cylinders are fully retracted for 30 to 45 seconds. This will force oil through the rephasing grooves and allow the series cylinder to be charged with oil.
- e. Continue the cycles until the cylinders respond with immediate solid actuation.

**Warning:** Escaping fluid under pressure can penetrate the skin causing serious injury. Avoid the hazard by relieving pressure before disconnecting hydraulic lines. Tighten all connections before applying pressure.

Search for leaks with a piece of cardboard. Protect hands and body from high pressure fluids.

If an accident occurs, see a doctor immediately. Any fluid injected into the skin must be surgically removed within a few hours or gangrene may result.



- f. After the wing cylinders are full, extend them to maximum length and remove the wood blocks.

Pin the rod end of the wing cylinders to the wing lugs using the special pins, wear sleeves, 1-1/4" STD. Flat Washers, and 1/4" DIA. x 2-1/2" Roll Pins as shown in the drawing below.

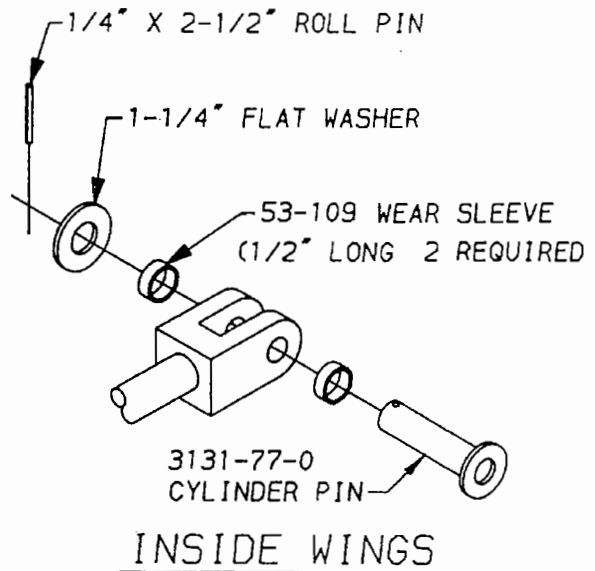
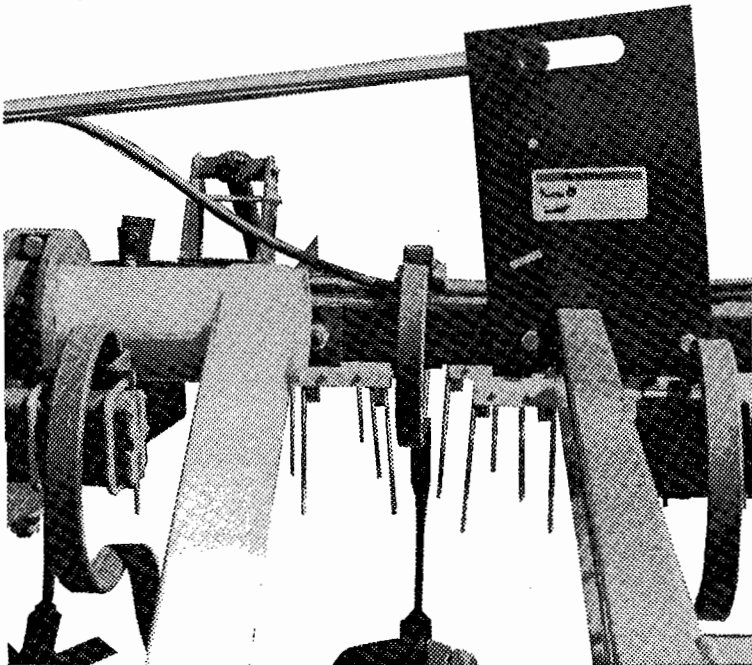

## MODEL 4237 & 4241 OUTER WING LIFT ARM WELDMENT

attaches to the outer wing with pin and TWO  
3/8" x 3" Roll Pins shown in photograph below.

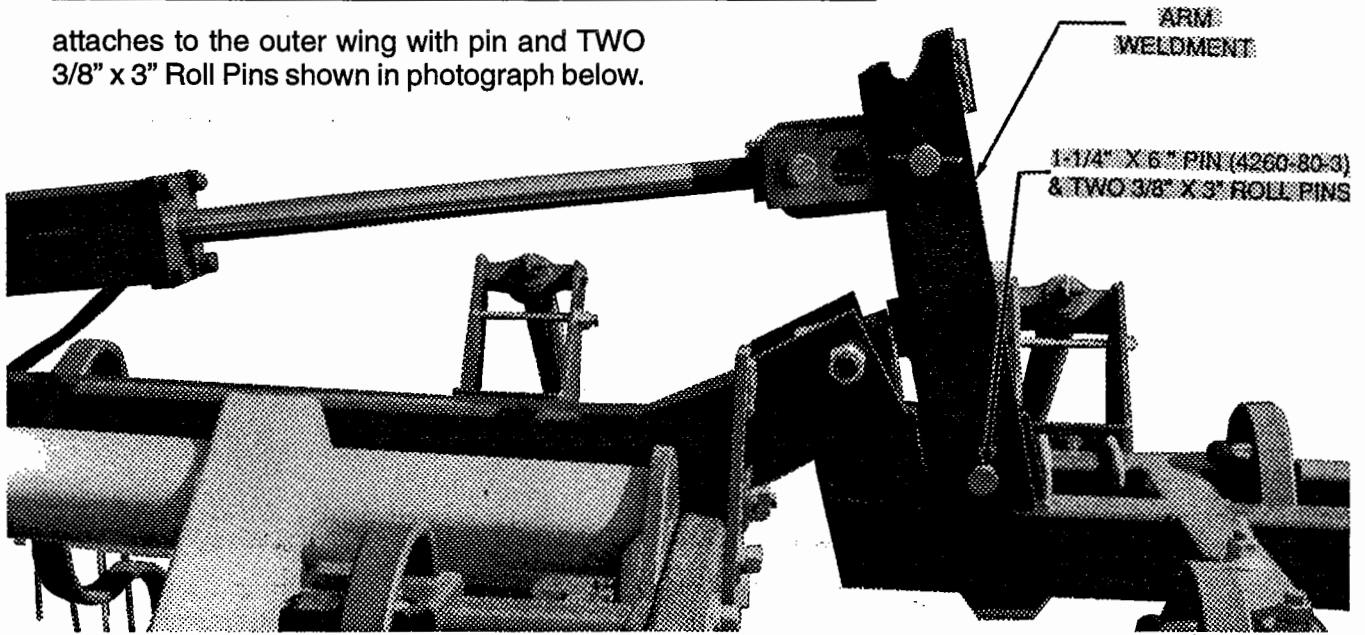

## IX. TRAIL HITCH ACCESSORY

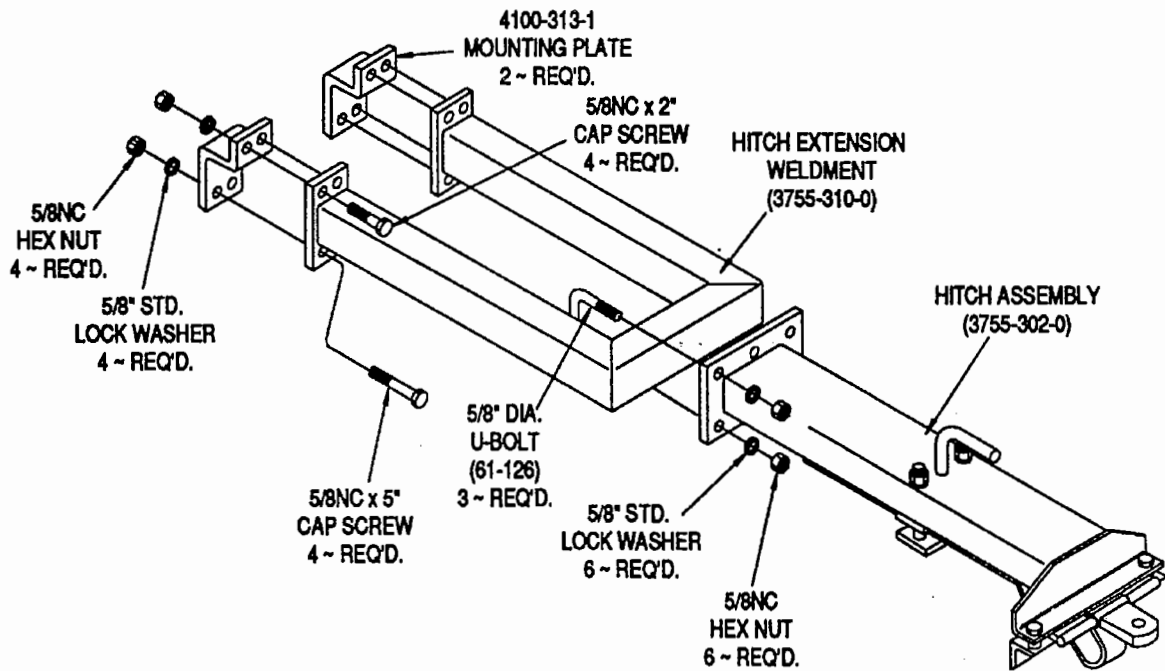

## X. REAR FRAME STAND

Two Rear Parking Stands have been provided because rear attachments cause the cultivators to be "tail heavy".

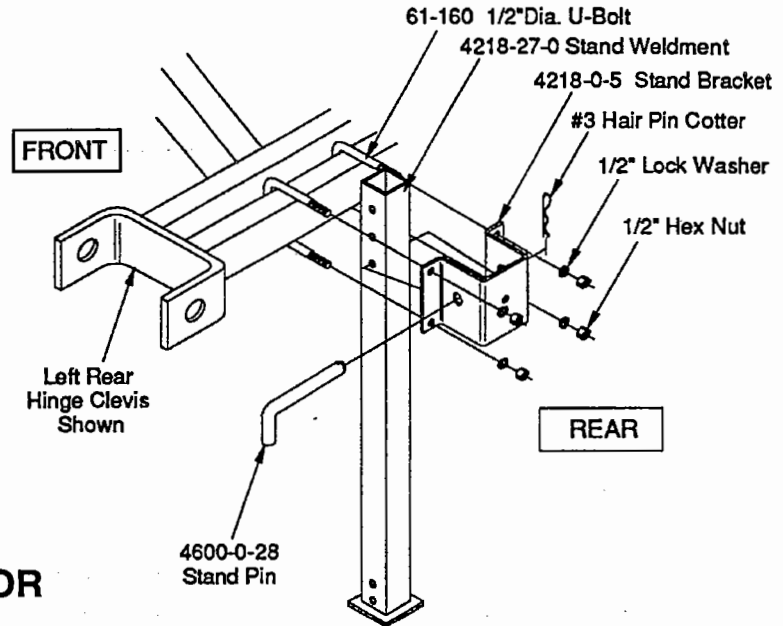

## XI. LEVELING THE CULTIVATOR

1. Retract the rocker cylinders and raise the cultivator.
2. Check the Depth Control Knob on the center section.
  - a. If equipped with Walking Beam Dual Wheels, there should be 1/4" of thread outside the cast knob.
  - b. If equipped with single wheels, remove the roll pin and rotate the knob until the threaded rod ends 1/8" inside of the knob. Drive the roll pin back into place.

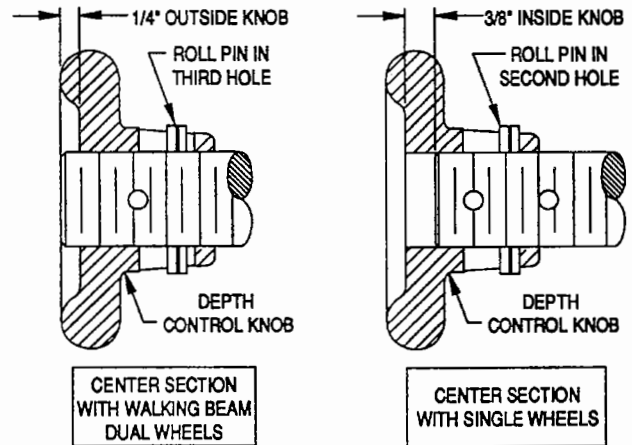

3. After the center knob has been adjusted and the roll pin is in place, screw the Depth Knob in tight against the end of the stop weldment.

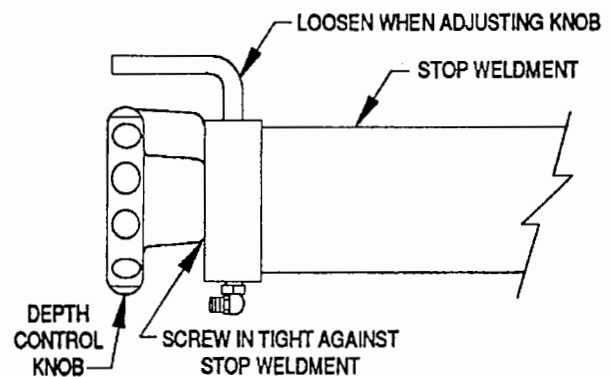

4. Lower the cultivator by fully extending the rocker cylinders. The depth stop should hold the center section sweeps slightly above the ground.

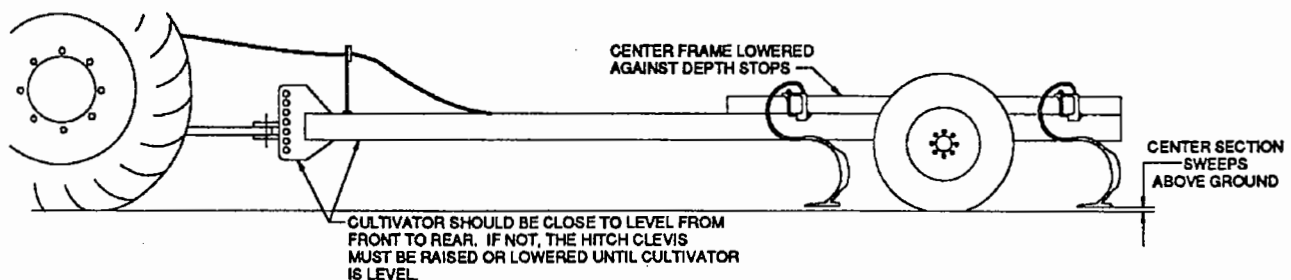

5. With the cultivator still in the lowered position, remove the roll pin in the wing depth stop knob and unscrew the knob from the depth stop assembly.

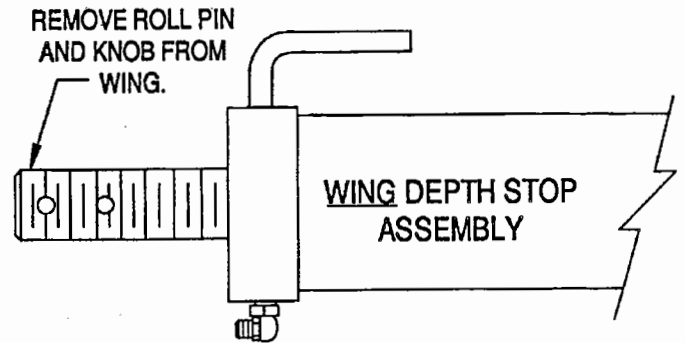

6. Note whether the wings are higher or lower than the center section.

**SPECIAL NOTE:** When leveling Model 4241 out of the ground, adjust the outer end of the outer wing 3/8" lower than the center and inside wing.

**IF WING IS HIGHER THAN CENTER SECTION:**

- a. Raise cultivator with tractor hydraulics to remove pressure from the depth stops.
- b. Rotate the threaded stop counter-clockwise one or two turns with a rod or punch.
- c. Lower cultivator against stops and check sweep height. If wing is still too high, repeat steps a) & b).

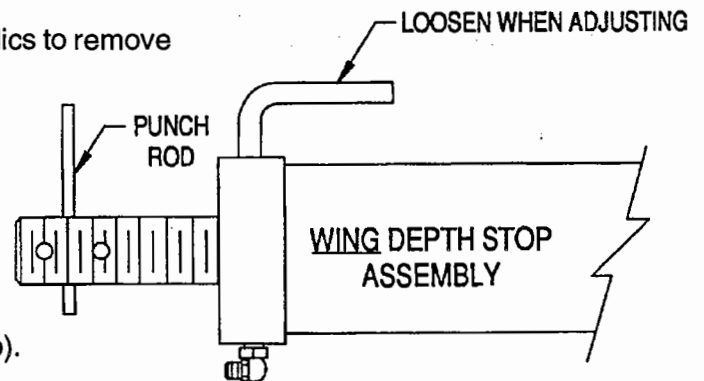

**IF WING IS LOWER THAN CENTER SECTION:**

- a. Raise cultivator with tractor hydraulics to remove pressure from the depth stops.
- b. Rotate the threaded stop clockwise one or two turns with a rod or punch.
- c. Lower cultivator against stops and check sweep height. If wing is still too low, repeat steps 1 & 2.

**IMPORTANT:** THE CULTIVATOR WILL ONLY BE LEVEL WHEN IT IS LOWERED DOWN AGAINST THE DEPTH STOPS.

7. When the cultivator is level and still in the lowered position, screw the wing depth stop knobs on tight against the stop weldment and retain it with the 1/4" Roll Pin.
8. Raise the cultivator and turn ALL of the Depth Adjustment Knobs out 10 complete turns. This will set the cultivator to a 2" to 3" plowing depth.

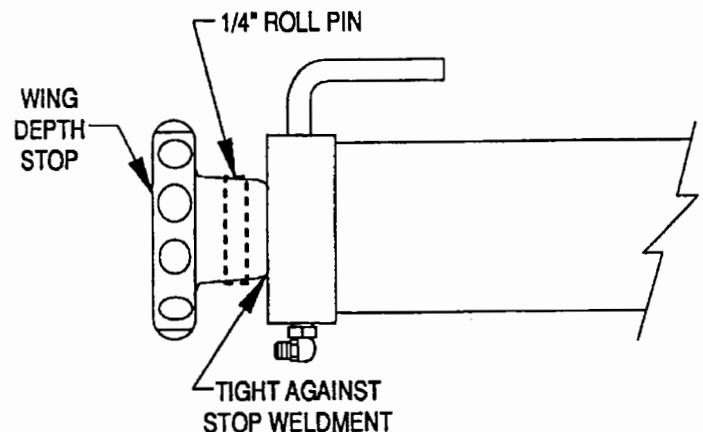

**XII. DECALS**

The DECALS are important to the safety of the operators and to others and must be attached to the cultivator at the proper locations. Some DECALS are applied to the proper location at the factory; however, these should be checked for location, and to be sure that they have not been damaged in shipping or set-up. Remove the protective backing from each remaining decal, and attach to the field cultivator at the locations shown on the parts drawing on page P66.

# 4200 TINE HARROWS

Revised 3/95

Model	No. Shanks	Cut Width	Tine Cut Width	Left Outside Wing	Left Inside Wing	Center	Right Inside Wing	Right Outside Wing	3-Row 11" Tine Group No.	3-Row 16" Tine Group No.	4-Row 16" Tine Group No.
4218	31	18' 1"	18' 9"	—	5' 0"	8' 9"	5' 0"	—	4200-521-0A	4200-121-0A	4200-321-0A
	33	19' 3"	20' 0"	—	6' 3"	7' 6"	6' 3"	—	4200-527-0A	4200-127-0A	4200-327-0A
	35	20' 5"	21' 3"	—	6' 3"	8' 9"	6' 3"	—	4200-533-0A	4200-133-0A	4200-333-0A
4223	37	21' 7"	22' 6"	—	7' 6"	7' 6"	7' 6"	—	4200-536-0A	4200-136-0A	4200-336-0A
	39	22' 9"	23' 9"	—	7' 6"	8' 9"	7' 6"	—	4200-543-0A	4200-143-0A	4200-343-0A
	41	23' 11"	25' 0"	—	8' 9"	7' 6"	8' 9"	—	4200-548-0A	4200-148-0A	4200-348-0A
4226	43	25' 1"	26' 3"	—	8' 9"	8' 9"	8' 9"	—	4200-557-0A	4200-157-0A	4200-357-0A
	45	26' 3"	27' 6"	—	10' 0"	7' 6"	10' 0"	—	4200-560-0A	4200-160-0A	4200-360-0A
	45	26' 3"	27' 6"	—	8' 9"	10' 0"	8' 9"	—	4200-561-0A	4200-161-0A	4200-361-0A
4231	47	27' 5"	28' 9"	—	8' 9"	11' 3"	8' 9"	—	4200-567-0A	4200-167-0A	4200-367-0A
	49	28' 7"	30' 0"	—	10' 0"	10' 0"	10' 0"	—	4200-573-0A	4200-173-0A	4200-373-0A
	51	29' 9"	31' 3"	—	10' 0"	11' 3"	10' 0"	—	4200-579-0A	4200-179-0A	4200-379-0A
4237	53	30' 11"	32' 6"	—	11' 3"	10' 0"	11' 3"	—	4200-585-0A	4200-185-0A	4200-385-0A
	55	32' 1"	32' 6"	—	11' 3"	10' 0"	11' 3"	—	4200-585-0A	4200-185-0A	4200-385-0A
	57	33' 3"	33' 9"	2' 6"	8' 9"	11' 3"	8' 9"	2' 6"	4200-592-0FA	4200-192-0FA	4200-392-0FA
4241	59	34' 5"	35' 0"	2' 6"	10' 0"	10' 0"	10' 0"	2' 6"	4200-594-0FA	4200-194-0FA	4200-394-0FA
	63	36' 9"	37' 6"	5' 0"	8' 9"	10' 0"	8' 9"	5' 0"	4200-608-0A	4200-208-0A	4200-408-0A
	65	37' 11"	38' 9"	5' 0"	8' 9"	11' 3"	8' 9"	5' 0"	4200-612-0A	4200-212-0A	4200-412-0F
4241	67	39' 1"	40' 0"	6' 3"	8' 9"	10' 0"	8' 9"	6' 3"	4200-668-0A	4200-262-0A	4200-468-0A
	69	40' 3"	41' 3"	6' 3"	8' 9"	11' 3"	8' 9"	6' 3"	4200-622-0A	4200-222-0A	4200-422-0A
	71	41' 5"	42' 6"	5' 0"	11' 3"	10' 0"	11' 3"	5' 0"	4200-626-0A	4200-226-0A	4200-426-0A
4241	73	42' 7"	43' 9"	6' 3"	10' 0"	11' 3"	10' 0"	6' 3"	4200-663-0A	4200-263-0A	4200-463-0A
	75	43' 9"	45' 0"	6' 3"	11' 3"	10' 0"	11' 3"	6' 3"	4200-664-0A	4200-264-0A	4200-464-0A
	77	44' 11"	46' 3"	7' 6"	10' 0"	11' 3"	10' 0"	7' 6"	4200-665-0A	4200-265-0A	4200-465-0A

## 4200 SPIKE HARROWS

Revised 10/94

Model	No. Shanks	Cut Width	Spike Cut Width	Left Outer Wing	Left Wing	Center	Right Wing	Right Outer Wing	3-Row Spike Group Number	5-Row Spike Group Number
4218	31	18' 1"	26' 10-1/2"	5' 7-1/2"	7' 6"	5' 7-1/2"	5' 7-1/2"	4200-846-0A	4200-1146-0A	
	33	19' 3"	20' 0"	6' 3"	7' 6"	6' 3"	6' 3"	4200-725-0A	4200-1025-0A	
	35	20' 5"	21' 3"	6' 10-1/2"	7' 6"	6' 10-1/2"	6' 10-1/2"	4200-847-0A	4200-1147-0A	
4223	37	21' 3"	22' 6"	7' 6"	7' 6"	7' 6"	7' 6"	4200-840-0A	4200-1148-0A	
	39	22' 6"	23' 9"	8' 1-1/2"	7' 6"	8' 1-1/2"	8' 1-1/2"	4200-849-0A	4200-1149-0A	
	41	23' 9"	25' 0"	8' 1-1/2"	4' 4-1/2" & 4' 4-1/2"	8' 1-1/2"	8' 1-1/2"	4200-850-0A	4200-1150-0A	
4226	43	25' 0"	26' 3"	4' 4-1/2" & 5' 0"	7' 6"	5' 0" & 4' 4-1/2"	5' 0" & 4' 4-1/2"	4200-851-0A	4200-1151-0A	
	45	26' 3"	26' 10-1/2"	4' 4-1/2" & 5' 0"	8' 1-1/2"	5' 0" & 4' 4-1/2"	5' 0" & 4' 4-1/2"	4200-852-0A	4200-1152-0A	
	45	27' 5"	26' 10-1/2"	8' 1-1/2"	5' 0" & 5' 7-1/2"	8' 1-1/2"	8' 1-1/2"	4200-853-0A	4200-1153-0A	
4231	47	28' 7"	28' 1-1/2"	4' 4-1/2" & 4' 4-1/2"	5' 0" & 5' 7-1/2"	4' 4-1/2" & 4' 4-1/2"	4' 4-1/2" & 4' 4-1/2"	4200-854-0A	4200-1154-0A	
	49	29' 9"	29' 4-1/2"	4' 4-1/2" & 5' 0"	5' 0" & 5' 7-1/2"	5' 0" & 4' 4-1/2"	5' 0" & 4' 4-1/2"	4200-855-0A	4200-1155-0A	
	51	30' 11"	30' 7-1/2"	5' 0" & 5' 0"	5' 0" & 5' 7-1/2"	5' 0" & 5' 0"	5' 0" & 5' 0"	4200-856-0A	4200-1156-0A	
4237	53	32' 1"	31' 10-1/2"	5' 0" & 5' 7-1/2"	5' 0" & 5' 7-1/2"	5' 7-1/2" & 5' 0"	5' 7-1/2" & 5' 0"	4200-857-0A	4200-1157-0A	
	55	33' 3"	33' 1-1/2"	5' 7-1/2" & 5' 7-1/2"	5' 0" & 5' 7-1/2"	5' 7-1/2" & 5' 7-1/2"	5' 7-1/2" & 5' 7-1/2"	4200-858-0A	4200-1158-0A	
	57	34' 5"	---	---	---	---	---	---	---	
4241	59	34' 5"	---	---	---	---	---	---	---	
	63	36' 9"	37' 6"	5' 0"	5' 7-1/2" & 5' 7-1/2"	8' 1-1/2"	8' 1-1/2"	5' 0"	4200-802-0A	---
	65	37' 11"	38' 9"	5' 7-1/2"	5' 7-1/2" & 5' 7-1/2"	5' 7-1/2" & 5' 7-1/2"	8' 1-1/2"	5' 7-1/2"	4200-808-0A	---
4241	67	39' 1"	40' 0"	6' 3"	5' 7-1/2" & 5' 7-1/2"	5' 7-1/2" & 5' 7-1/2"	8' 1-1/2"	6' 3"	4200-814-0A	---
	69	40' 3"	41' 3"	6' 10-1/2"	5' 7-1/2" & 5' 7-1/2"	5' 7-1/2" & 5' 7-1/2"	8' 1-1/2"	6' 10-1/2"	4200-820-0A	---
	71	41' 5"	42' 6"	5' 0"	5' 7-1/2" & 5' 0"	5' 7-1/2" & 5' 7-1/2"	5' 0" & 5' 7-1/2"	5' 0"	4200-860-0A	---
4241	73	42' 7"	43' 9"	5' 7-1/2"	5' 7-1/2" & 5' 0"	5' 7-1/2" & 5' 7-1/2"	5' 0" & 5' 7-1/2"	5' 7-1/2"	4200-861-0A	---
	75	43' 9"	45' 4-1/2"	6' 3"	5' 0" & 5' 7-1/2"	5' 7-1/2" & 5' 0"	5' 7-1/2" & 5' 0"	6' 3"	4200-862-0A	---
	77	44' 11"	45' 7-1/2"	6' 10-1/2"	5' 0" & 5' 7-1/2"	5' 7-1/2" & 5' 0"	5' 7-1/2" & 5' 0"	6' 10-1/2"	4200-863-0A	---

# 4200 TINE & REEL / SPIKE & REEL HARROWS

Revised 10/94

Model	No. Shanks	Cultivator Cut Width	Attachment Cut Width	Left Wing	Center	Right Wing	Reel & 3-Row Tine Group Number	Reel & 3-Row Spike Group Number
4218	31	18' 1"	18' 9"	60"	105"	60"	6118-300-0A	6118-350-0A
	33	19' 3"						
	35	20' 5"						
4223	37	21' 7"	22' 6"	75"	120"	75"	6121-300-0A	6121-350-0A
	39	22' 9"						
	41	23' 11"	25' 0"	105"	90"	105"	6124-300-0A	6124-350-0A
4226	43	25' 1"						
	45	26' 3"						
	45	26' 3"	27' 6"	90"	150"	90"	6127-300-0A	6127-350-0A
	47	27' 5"						
	49	28' 7"						
4231	51	29' 9"	31' 3"	120"	135"	120"	6130-300-0A	6130-350-0A
	53	30' 11"	32' 6"	120"	150"	120"	6131-300-0A	6131-350-0A
	55	32' 1"						
4237	57	33' 3"						
	59	34' 5"						
	63	36' 9"						
	65	37' 11"						
4241	67	39' 1"						
	69	40' 3"						
	71	41' 5"						
4241	73	42' 7"						
	75	43' 9"						
	77	44' 11"						



**M O D E L 4 2 1 8**  
**EQUIPPED WITH K-TINE SHANKS**

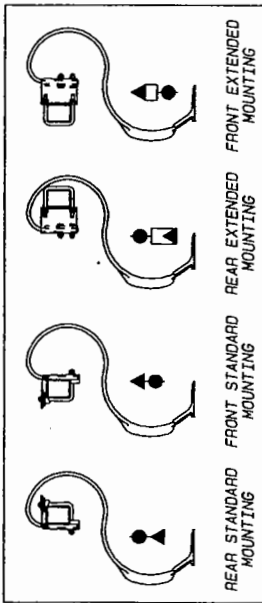

- 1 SHANK EXT. 4200-67-07
- 2 SHANK EXT. 4200-69-07
- 3 SHANK EXT. 4200-75-07

**7" SPACING**  
**★ REAR STAND LOCATIONS**

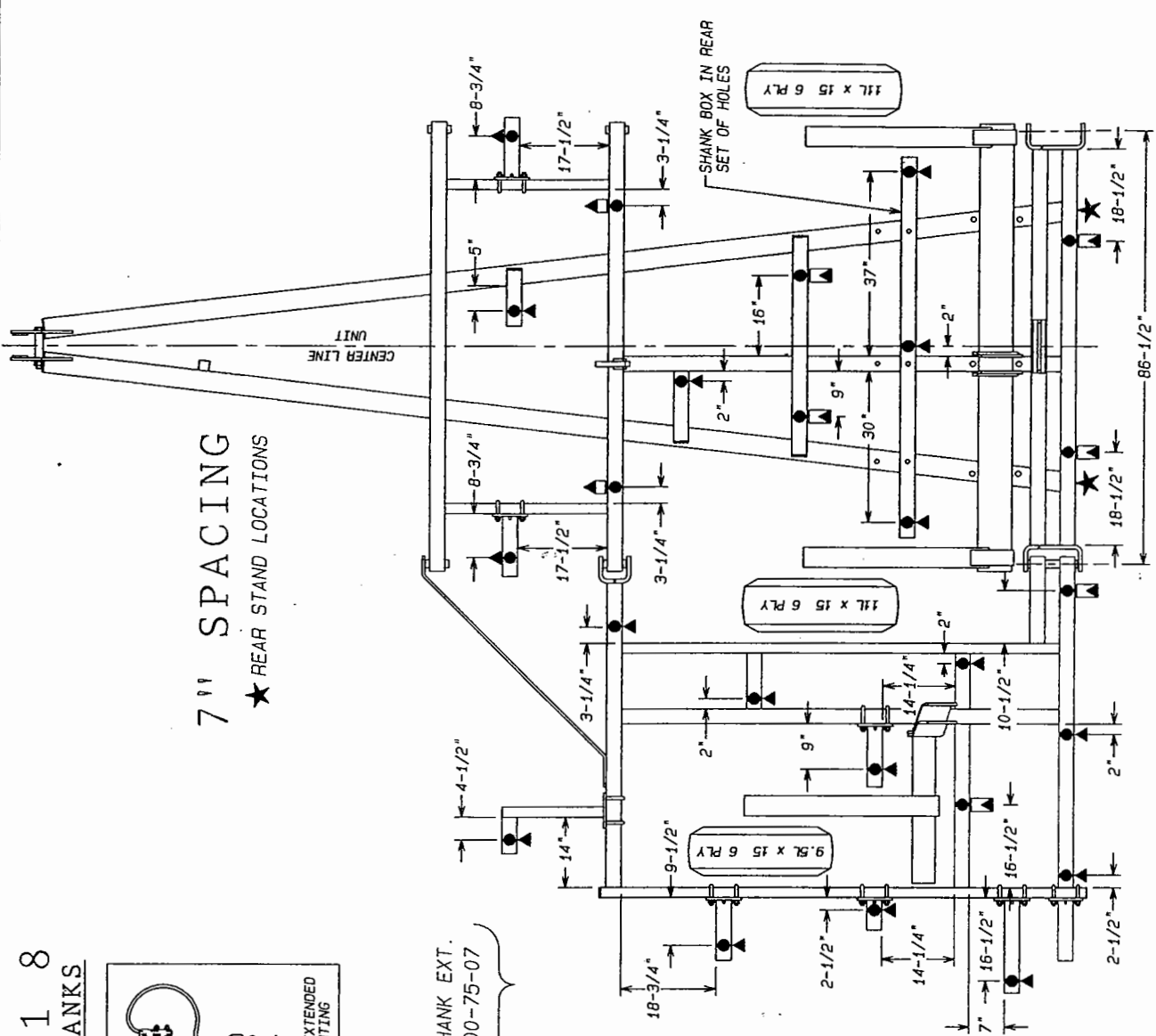

M4200-70

# M O D E L 4 2 1 8

## EQUIPPED WITH 2-PIECE K-TINE SHANKS

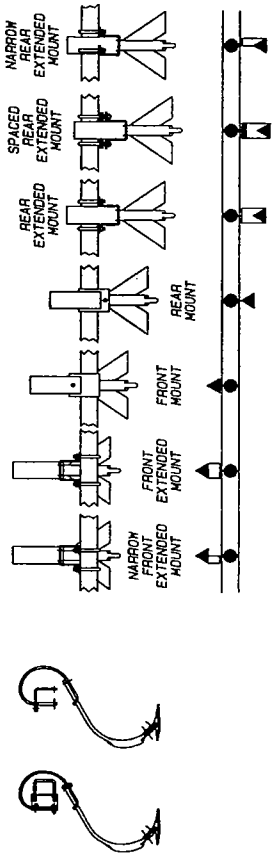

- 1 SHANK EXT. 4200-77-07
- 2 SHANK EXT. 4200-79-07
- 3 SHANK EXT. 4200-85-07

7" SPACING  
★ REAR STAND LOCATIONS

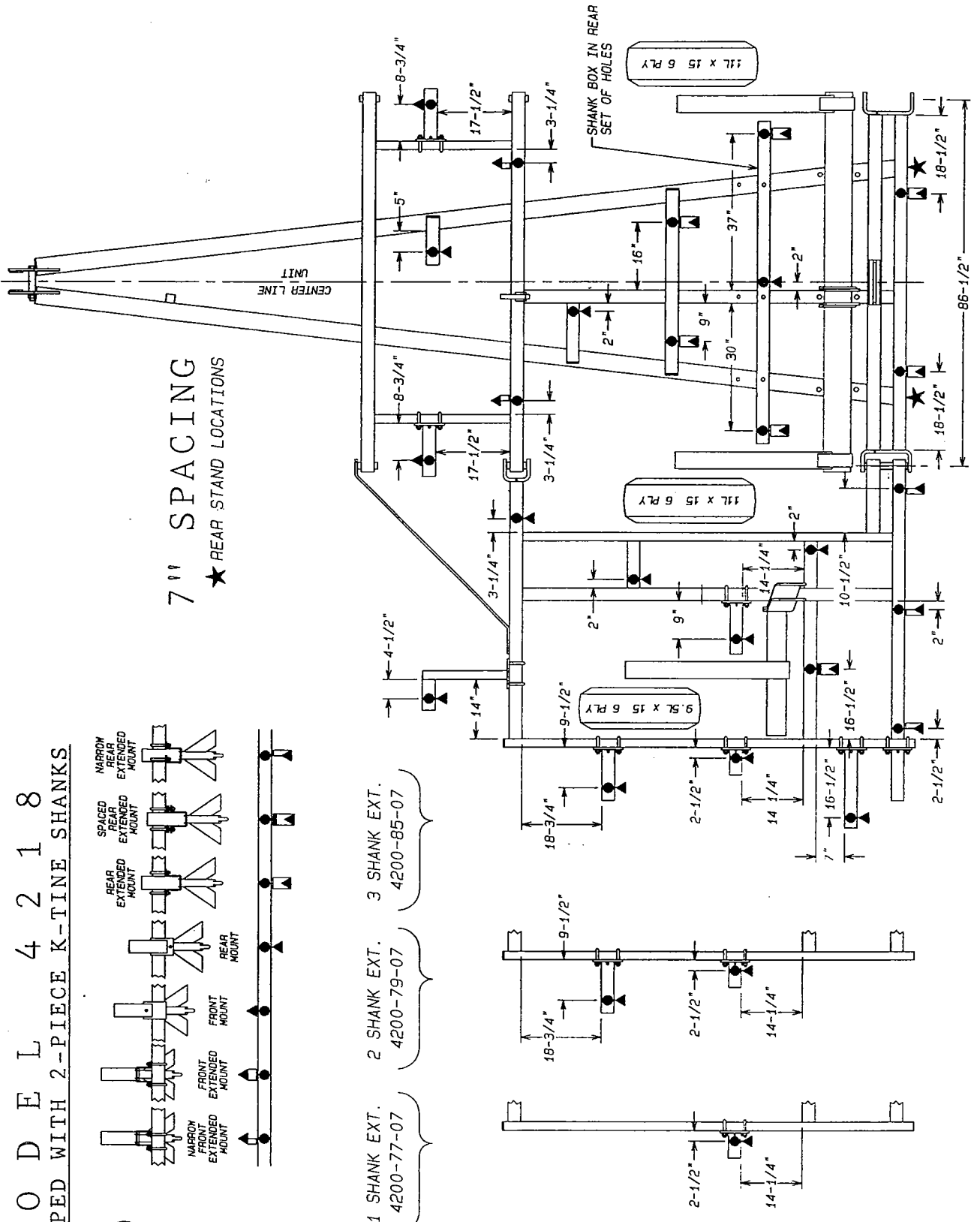









# MODEL 4241 EQUIPPED WITH 2-PIECE K-TINE SHANKS

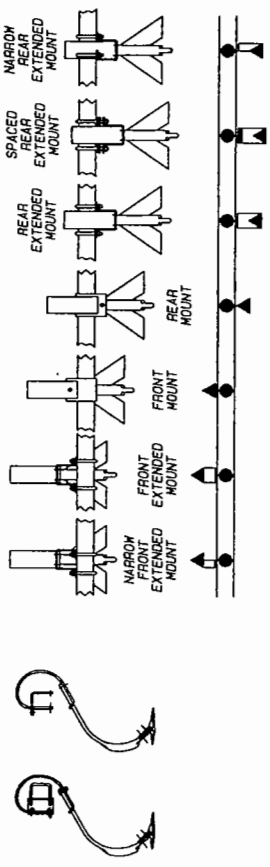

7" SPACING  
★ REAR STAND LOCATIONS

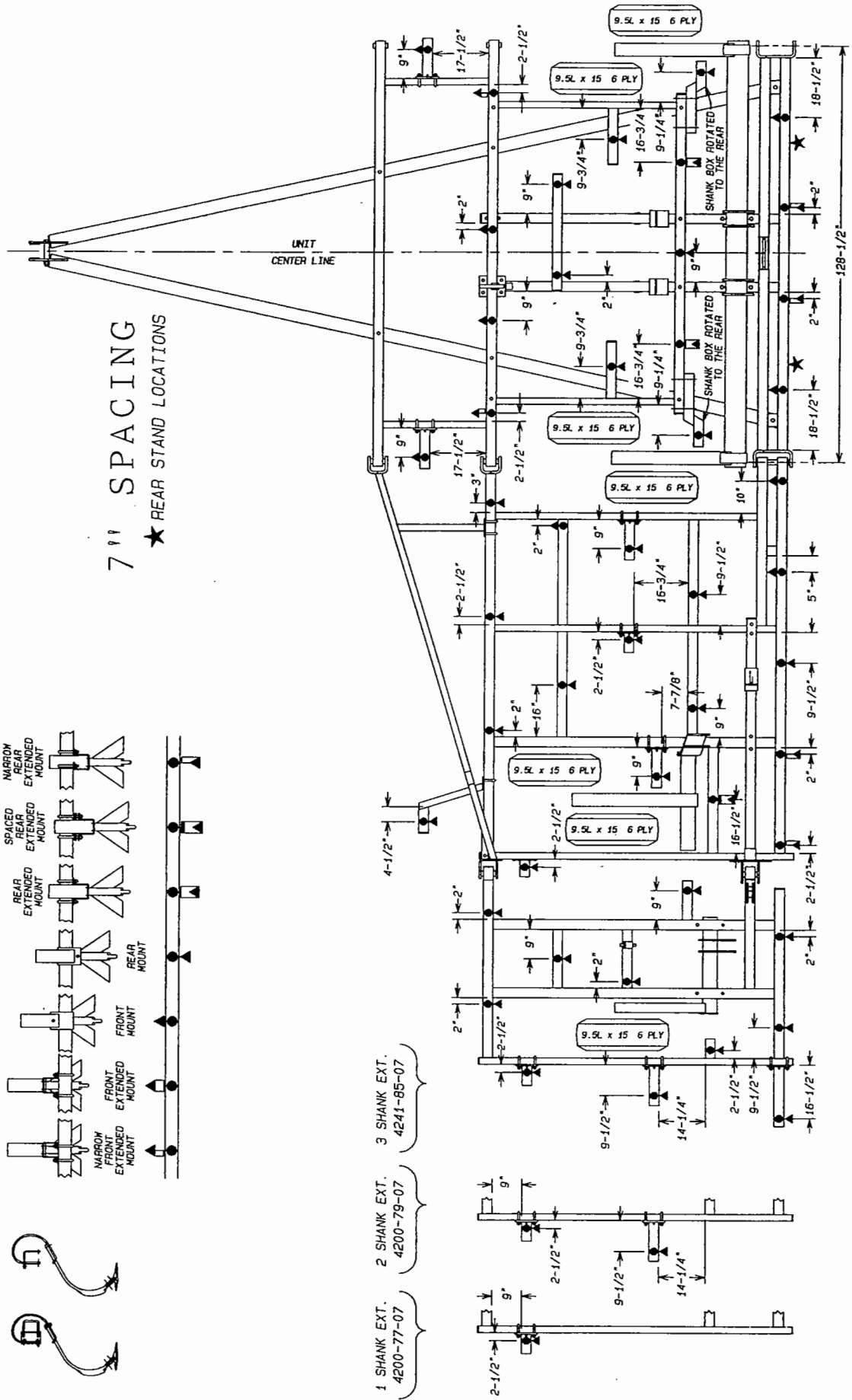



# SAFETY FIRST

Be observant and safety minded. Recognize and correct or avoid hazardous conditions before an accident can happen. Most accidents can be prevented by practicing simple, fundamental safety rules.

1. Read and understand the implement and tractor owner's manuals before operating.
2. Be sure safety decals and reflectors are clean and in place.
3. Do not climb or walk on gangs or frames or tires.
4. Never position yourself under any portion of implement unless the transport lock is engaged or entire unit is lowered to the ground.
5. Stop engine before leaving the operator's position to adjust, lubricate, clean or unclog the machine.
6. Do not stand between the implement and tractor unless the tractor brakes are locked and engine is shut off.
7. Do not stand on or straddle a tongue when unhitching.
8. Always store a winged implement with the wings down.
9. Never remove locking pins until hydraulic cylinders and lines are full of oil and free of air. See Operating Instructions for proper method of removing air.
10. Never use machinery until all safety devices are in place.
11. Release all hydraulic pressure before shutdown periods.
12. Comply with Federal, State and local laws.
13. Use a Slow-Moving-Vehicle (SMV) emblem when transporting.
14. Always use a safety chain of tensile strength equal to the gross weight of the implement and attachments when roading.
15. Towing vehicle weight must exceed weight of towed implement.
16. Check wheel bolts before and during transport.
17. Always use wing locks and road locks to hold raised positions.
18. Never permit riders on implement.
19. Do not road an implement over 15 miles per hour on the best surface conditions. Reduce speed when going up or down hills and when approaching ditches.
20. Keep small children away from farm equipment.
21. Never modify an implement without permission from the Krause Engineering Department.
22. Always use authorized Krause parts.